

# Ninth Annual Institute

## Tax Aspects of Mergers and Acquisitions

Penn State/Dickinson School of Law  
New York City Bar/City Bar Center for CLE

# Taxable Acquisitions

New York, NY  
April 19, 2012

William D. Alexander  
Associate Chief Counsel (Corporate)  
Washington, D.C.

Mark J. Silverman  
Steptoe & Johnson LLP  
Washington, D.C.

Robert H. Wellen  
Ivins, Phillips & Barker, Chartered  
Washington, D.C.

# Table of Contents

• Asset Sale and Purchase	2
• Stock Sale and Purchase	4
• Section 1060	9
• Section 338 Overview	22
• Purchase	33
• Qualified Stock Purchase	48
• Insolvency	72
• Bargain Purchase	87
• Unwanted Assets	91
• Other Section 338(h)(10) Situations	96
• Economic Substance Codification – Impact on Section 338	100
• Section 197	182
• Section 336(e) Proposed Regulations	195
• Step Transaction Issues: Reorganizations	227
• Step Transaction Issues: Sections 302, 304, and 305	238
• “D” Reorganizations	246
• Contingent Purchase Price	276
• Escrows	301
• Contingent Obligations in Taxable Asset Acquisitions	305
• Contingent Obligations in Taxable Stock Acquisitions	326
• Indemnities	330
• Rescission	336

# Asset Sale and Purchase

## Asset Sale—General

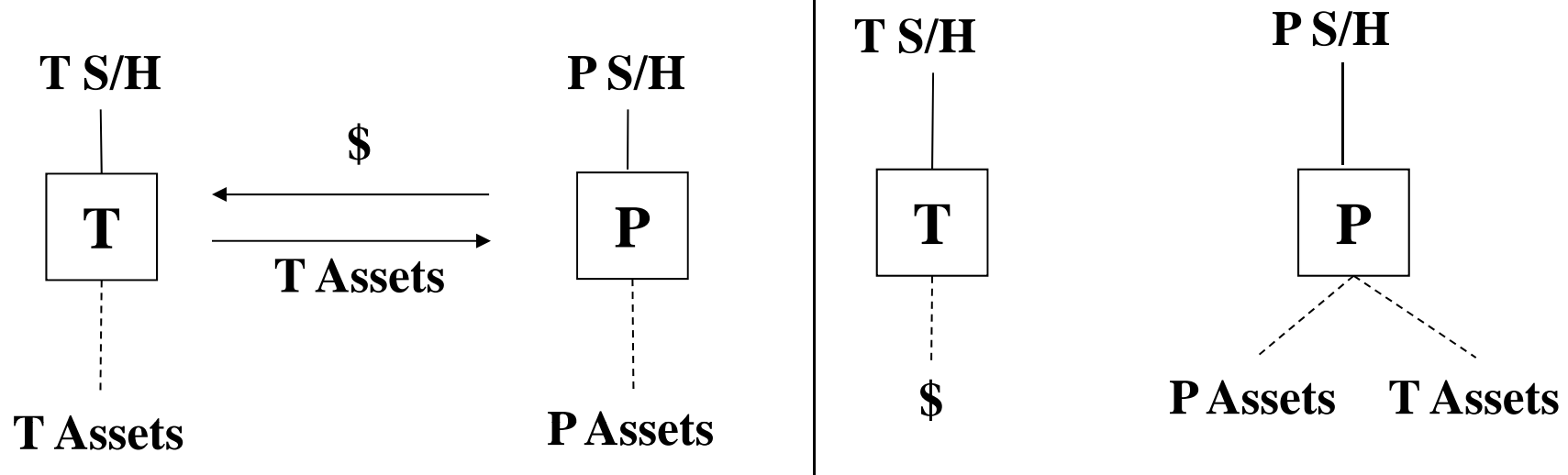

- T recognizes gain or loss.
- P takes a cost basis in the T assets.
- Under section 1060, the consideration is allocated to 7 classes of assets (residual method).
- Cash remains in T's hands. Cash to T S/H will be taxable to T S/H as a dividend or as capital gain (redemption proceeds or partial or complete liquidation).
- If T S/H is T's corporate parent, T may transfer the cash to T S/H as a dividend subject to 100% dividends-received deduction or as a liquidation subject to section 332.
- If T S/H and T file consolidated returns, T may transfer the cash to T S/H as a dividend, tax-free (but TS/H's basis in the T stock will be reduced) or as a liquidation subject to section 332
- T S/H and T may obtain the same result via a forward cash merger of T into D.

# Stock Sale and Purchase

## Stock Sale—General

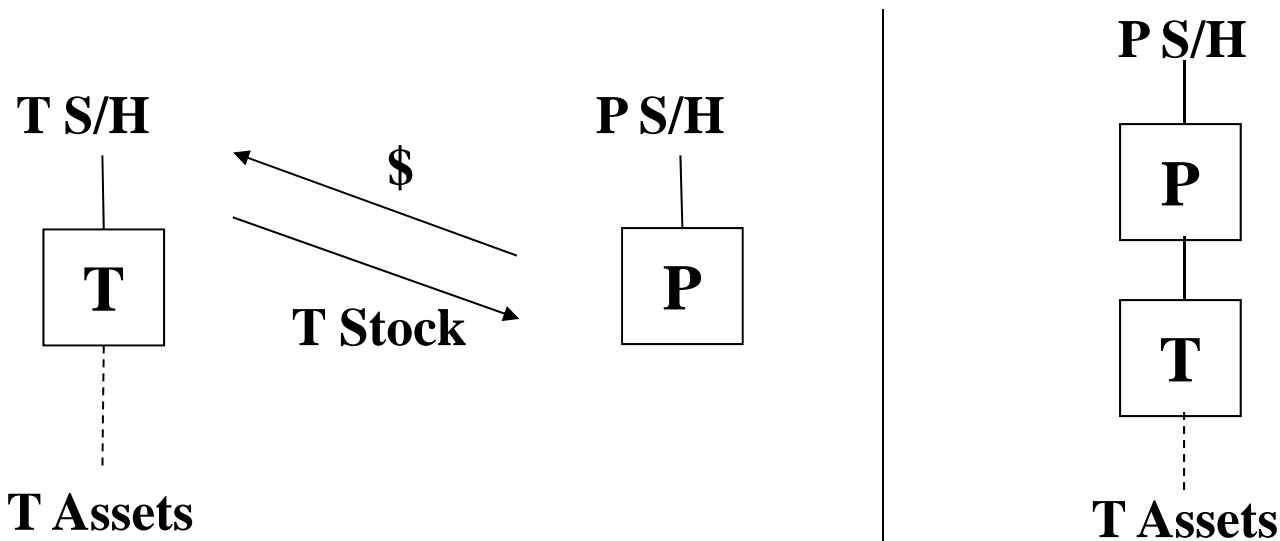

- T does not recognize gain or loss.
- T S/H recognize gain or loss on sale of stock.
- T's basis in the T assets ("inside basis") and T's tax attributes are unaffected (apart from section 382 limitation and the like).
- If T S/H and T file consolidated returns, (1) a loss recognized by T S/H may be disallowed, and (2) T's E&P earned while T was a group member stays behind in the T S/H group.
- P's basis in the T stock is equal to the fair market value of the consideration paid.
- Same results if the T stock is sold to a disregarded entity owned by P.
- Same results if P forms a new subsidiary, S, and S is merged into T, with T S/H receiving cash.
- See sections 355(d) and (e).

## Stock Sale—Variations

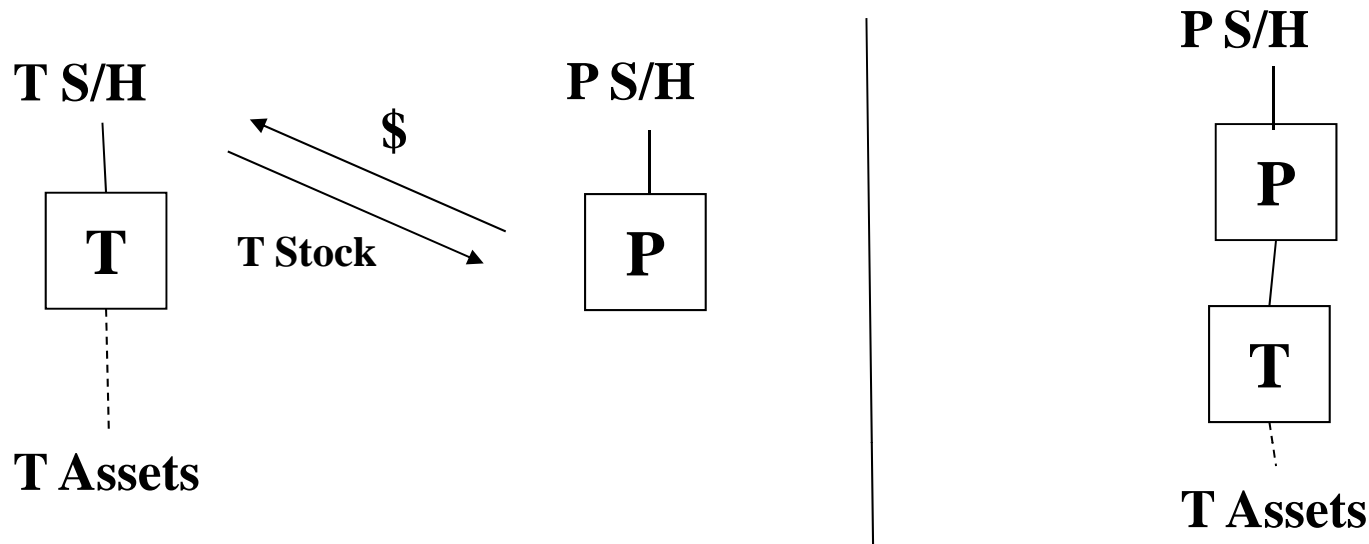

### Variations

1. T distributes a cash dividend to T S/H before the stock sale.
2. T redeems part of T S/H's stock, and T S/H sells the rest of the T stock to P.
3. At the time of the sale, T has unused NOL carryovers.
4. T and T S/H are members of a consolidated group.
  - a. T S/H sells the T stock at a gain, and other group members have losses.
  - b. T S/H sells the T stock at a gain, and T has unused losses.
  - c. T S/H sells the T stock at a loss.

# Stock Sale With Indemnity

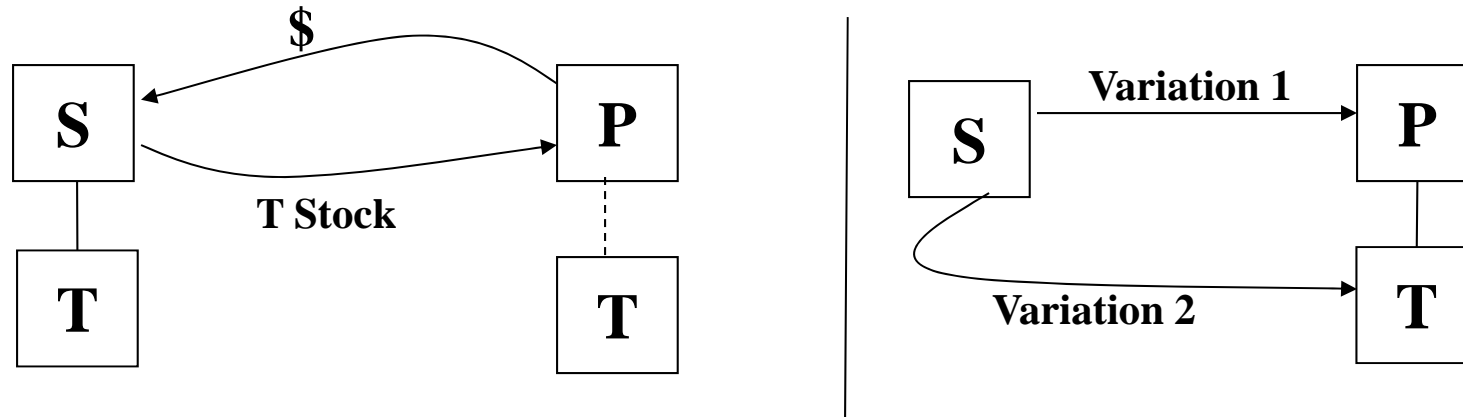

- S owns all the stock of T, which owns and operates a manufacturing facility.
- S sells the T stock to P for cash..
- Variation 1. At the time of the sale of the T stock, T is the defendant in a patent infringement lawsuit. In connection with the sale, S agrees to indemnify T against an adverse judgment. Five years after closing, a judgment is entered against T for damages plus interest dating back to three years before the closing. S pays the judgment.
- Variation 2. Five years after closing, P claims that S misrepresented the mechanical condition of T's operating facility. To settle the claim, S makes a payment to P. The payment consists of the cost of repairing and upgrading the facility plus interest from the date of closing.

*Estate of McGlothlin v. Commissioner*, 370 F.2d 729 (5<sup>th</sup> Cir. 1967)

*VCA Corporation v. United States*, 566 F.2d 1192 (Ct. Cl. 1977)

Rev. Rul. 58-374, 1958-2 C.B. 396

Rev. Rul. 83-73, 1983-1 C.B. 84

GCM 38977 (Apr. 8, 1982)



## Stock Sale—Section 338 Election

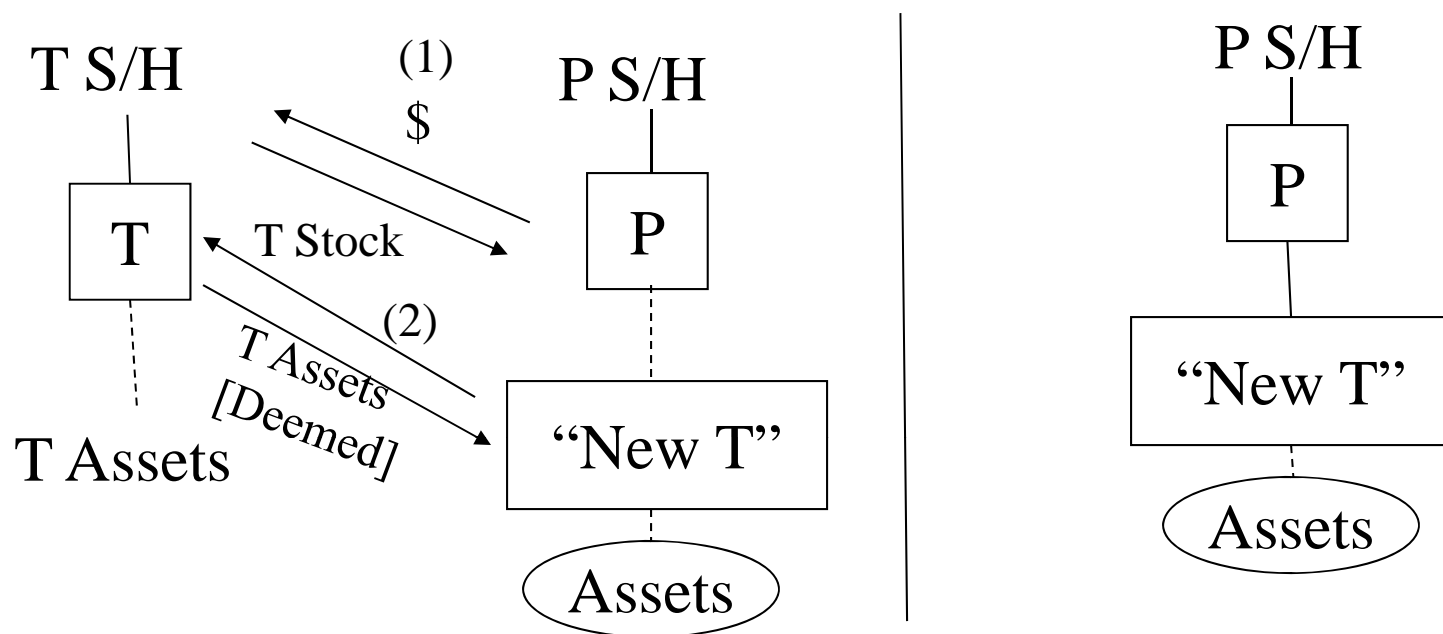

- Section 338(g) election is made unilaterally by P. It does not affect T S/H.
- Election results in deemed taxable sale by T of all its assets.
- Gain or loss is recognized to T in a separate, one-transaction return, not in consolidated group of either T S/H or P.
- If T is a domestic corporation with built-in gain, election is not attractive unless, *e.g.*, T has losses to shelter the gain.
- If T is a foreign corporation, election may be attractive to step up T's inside basis for U.S. tax purposes, eliminate historic earnings and profits, etc.

# Section 1060

## Section 1060

- Section 1060 applies to any "applicable asset acquisition." Section 1060(a).
  - An applicable asset acquisition is any transfer of assets constituting a trade or business if the purchaser's basis in the acquired assets is determined wholly by reference to the consideration paid for such assets. Section 1060(c).
  - Regulations broadly define "assets constituting a trade or business" as consisting of any group of assets (i) the use of which would constitute an active trade or business for purposes of section 355, or (ii) to which goodwill or going concern value could under any circumstances attach. Treas. Reg. § 1.1060-1(b)(2)(i).
  - Prior to the enactment of section 1060 as part of the 1986 Act, taxpayers and the government had frequently skirmished over purchase price allocations.
- If section 1060 applies to a transaction, the "consideration received" for the acquired assets must be allocated among the assets in accordance with regulations under section 338(b)(5). Section 1060(a). *See also* Treas. Reg. § 1.1060-1(c)(2).
  - The regulations require that the consideration be allocated among the assets under the "residual method."
- If the transaction is an applicable asset acquisition, each party must satisfy certain reporting requirements. Section 1060 also imposes certain reporting requirements with respect to specific transactions that are not applicable asset acquisitions.

## Section 1060 Regulations

- The IRS issued regulations under sections 338 and 1060. T.D. 8940 (February 12, 2001). These regulations are substantially the same as temporary regulations issued on January 5, 2000 (T.D. 8858), and proposed regulations issued on August 10, 1999 (REG-107069-97, 64 Fed. Reg. 43,461). The regulations are generally effective for asset acquisitions occurring after March 16, 2001.
- The preamble states that the proposed regulations were intended to clarify the treatment of, and provide consistent rules (where possible) for, both deemed and actual asset acquisitions under sections 338 and 1060.
- Treas. Reg. § 1.160-1(c)(2) incorporates the residual method by cross reference to the final section 338 regulations (Treas. Reg. §§ 1.338-6 and 1.338-7).

## Section 1060 Regulations Continued

- The regulations clarify that:
  - A trade or business is present if goodwill or going concern value could attach to the group of assets, regardless of whether any value will eventually be allocated to the residual class (Class VII). Treas. Reg. § 1.1060-1(b)(2)(iii).
  - The presence of section 197 intangibles is a factor to be considered in determining whether goodwill or going concern value could attach. Treas. Reg. § 1.1060-1(b)(2)(iii)(A).
  - A purchaser is subject to section 1060 even if the seller in the transaction is treated as selling something different from what the purchaser is treated as purchasing. Treas. Reg. § 1.1060-1(b)(4).
  - In determining whether a group of assets constitute a trade or business, all transfers from the seller to the purchaser in a series of related transactions are aggregated. Treas. Reg. § 1.1060-1(b)(5).
  - As long as any part of the assets are a trade or business, all the assets are to be treated as a single trade or business for purposes of applying the residual method. Treas. Reg. § 1.1060-1(b)(6).

## Final Section 1060 Regulations Continued

- If, in connection with an applicable asset acquisition, the seller enters into a covenant not to compete with the purchaser, that covenant is treated as an asset transferred as part of a trade or business. Treas. Reg. § 1.1060-1(b)(7).
- The buyer and seller may adjust their allocation of consideration to particular assets for costs incurred which are specifically identified with those assets. Thus, the total amount the seller allocates to an asset for which it incurs specifically identifiable costs would be less than its fair market value and, for the purchaser, greater than its fair market value. Treas. Reg. §1.1060-1(c)(3).

## Section 1060 Regulations Continued

- The seven asset classes under the section 338 regulations are incorporated in the section 1060 regulations:
  - Class I -- cash and general deposit accounts (including savings and checking accounts) other than certificates of deposit held in banks, savings and loan associations, and other depository institutions.
  - Class II -- actively traded personal property within the meaning of section 1092(d)(1) and Treas. Reg. § 1.1092(d)-1, certificates of deposits, and foreign currency. Class II assets do not include stock of target affiliates, other than actively traded stock described in section 1504(a)(4).
  - Class III -- assets that the taxpayer marks to market at least annually for Federal income tax purposes and debt instruments (including accounts receivable but excluding certain other debt instruments).
  - Class IV -- stock in the trade of the taxpayer or other property of a kind which would properly be included in the inventory of taxpayer if on hand at the close of the taxable year, or property held by the taxpayer primarily for sale to customers in the ordinary course of its trade or business.
  - Class V -- all assets other than Class I, II, III, IV, VI, and VII assets.
  - Class VI -- all section 197 intangibles, as defined in section 197, except goodwill and going concern value.
  - Class VII -- goodwill and going concern value (whether or not the goodwill and going concern value qualifies as a section 197 intangible).

# Allocation

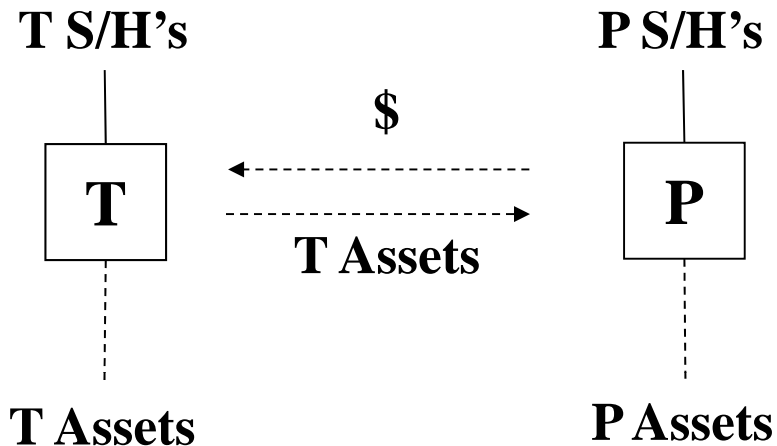

- **Purchase Price = \$1000**
- **T Assets include:**
  - **Cash:** **\$100**
  - **Stock portfolio** **\$125**
  - **Accounts Receivable** **\$100**
  - **Inventory** **\$150**
  - **Land** **\$150**
  - **Building** **\$200**

- Allocation using Residual Method:

- Class I (cash) = \$100
- Class II (stock) = \$125
- Class III (accounts receivable) = \$100
- Class IV (inventory) = \$150
- Class V (land + building) = \$350
  
- Total FMV of Assets in classes I-V = \$825
  
- Class VII (goodwill and going concern) = \$1000 - \$825 = \$175



# Reporting Requirements

- Form 8594. The parties to an applicable asset acquisition are each required to file an information statement:
- Who Must File
  - Both the purchaser and seller are required to file Form 8594.
  - The Form 8594 must be attached to each filer's timely filed Federal income tax return.
  - Taxpayers are not required to file Form 8594 if, pursuant to section 1031, the assets of a trade or business are exchanged for the assets of another trade or business.
- When and Where to File
  - The seller and purchaser must file Form 8594 as an attachment to their respective income tax return for the year in which the sale date occurred.
  - If any amount allocated to an asset is either increased or decreased in a subsequent year, the seller and/or purchaser (whoever is effected by the increase or decrease) must complete Parts I and III of Form 8594 and attach the Form to the income tax return for the year in which the increase or decrease is taken into account.
- Required Information
  - Form 8594 requires the following information:
    - The name, address, and taxpayer identification number of the seller and the purchaser, and the date of the sale/purchase.
    - The total amount of consideration for the assets.
    - The actual amount of Class I assets, and the aggregate fair market value of the assets included in each of Class II, III, IV, V, and VI and VII; Class VI and VII are grouped together on Form 8594.
    - The sum of the aggregate fair market values of all of the Class I - VII assets.
    - The amount of the sales price allocated to each asset Class (i.e., Class I - VI and VII).
    - Whether the allocation of purchase price was provided for in a sales contract or other written document signed by both parties; if the answer is yes, whether the aggregate fair market values for each asset class as listed on Form 8594 are same as the amounts agreed upon in the sales contract or other written document.
    - Whether there is a related covenant not to compete, employment or management contract, or similar arrangement with the seller (or managers, directors, owners, or employees of the seller); if so, the parties must attach a schedule specifying the type of agreement and the maximum consideration (exclusive of interest) to be paid pursuant to such agreement.
- Other Specified Transactions
  - The reporting requirements also apply to certain transactions that ordinarily are not applicable asset acquisitions. These transactions include:
    - A distribution of partnership property or a transfer of a partnership interest where section 755 applies (section 1060(d)(2)); and
    - A transfer by a 10-percent (by value) owner of an entity of any interest in such entity if, in connection with the transfer, the owner (or a related person) enters into an employment contract, covenant not to compete, royalty or lease agreement, or other agreement with the transferee (section 1060(e)(1)); the information to be provided in a section 1060(e) transaction is to be set forth in regulations, which have yet to be issued.

## Applicable Asset Acquisition

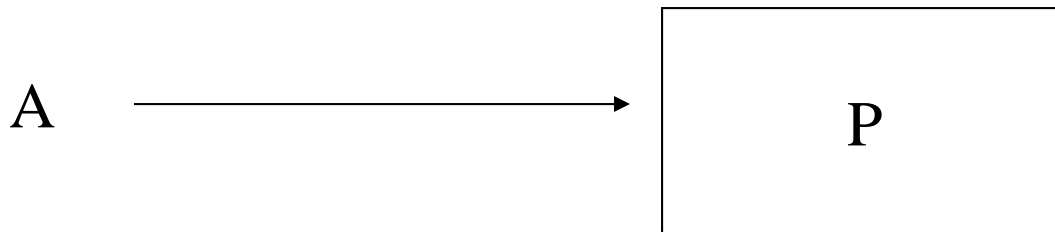

	<u>FMV</u>	<u>Basis</u>
Land	\$150,000	\$100,000
Building	\$250,000	\$0
Covenant Not to Compete	\$100,000	

Does section 1060 apply?

Do the assets constitute a trade or business?

## Applicable Asset Acquisition Continued

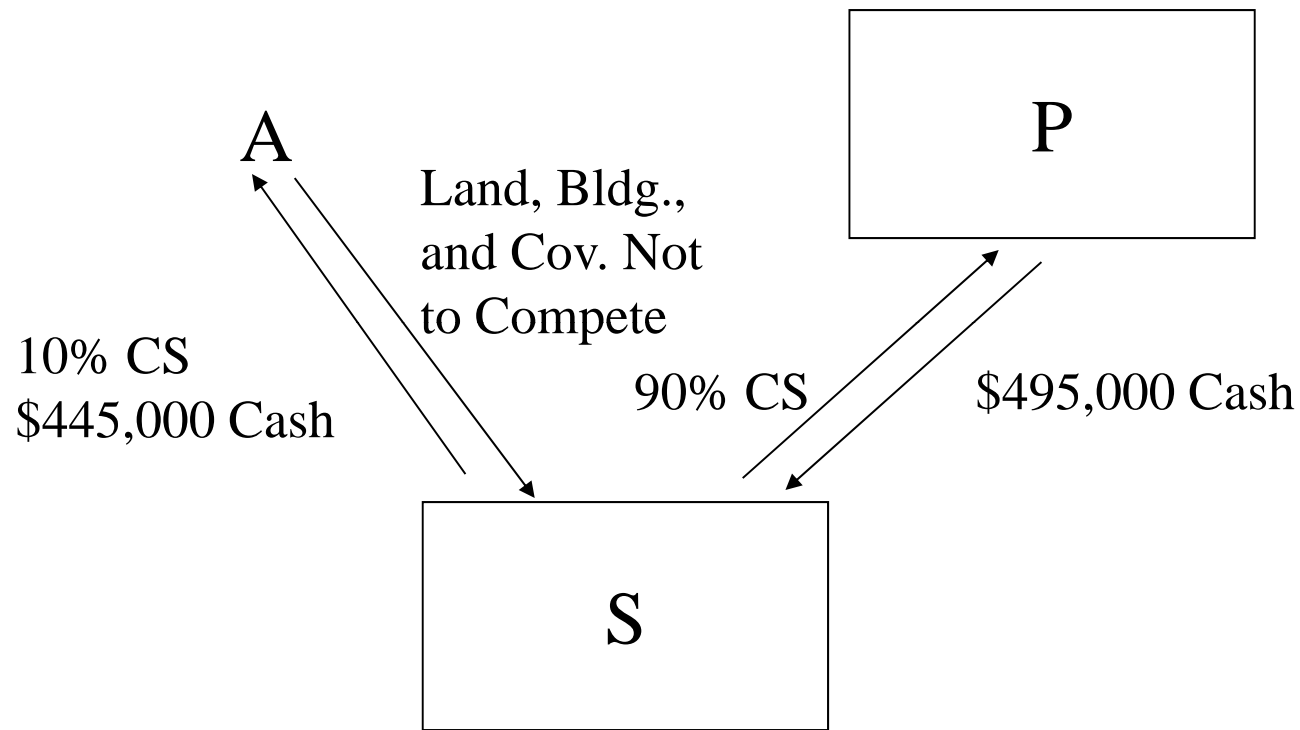

Section 1060 does not apply.

What is S's basis in the assets transferred by A to S?

## Applicable Asset Acquisition Continued

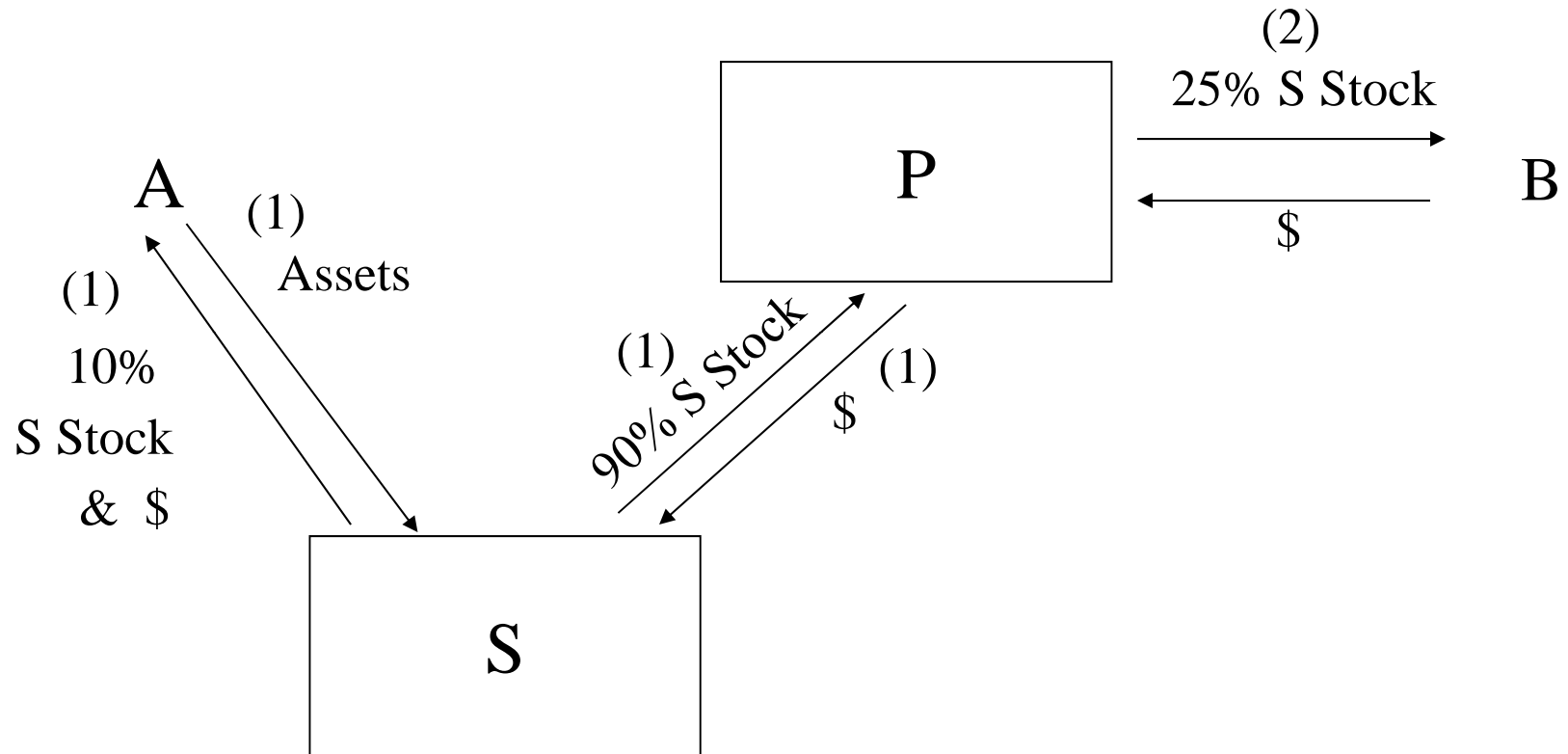

Busted section 351; section 1060 applies.

# Applicable Asset Acquisition Continued

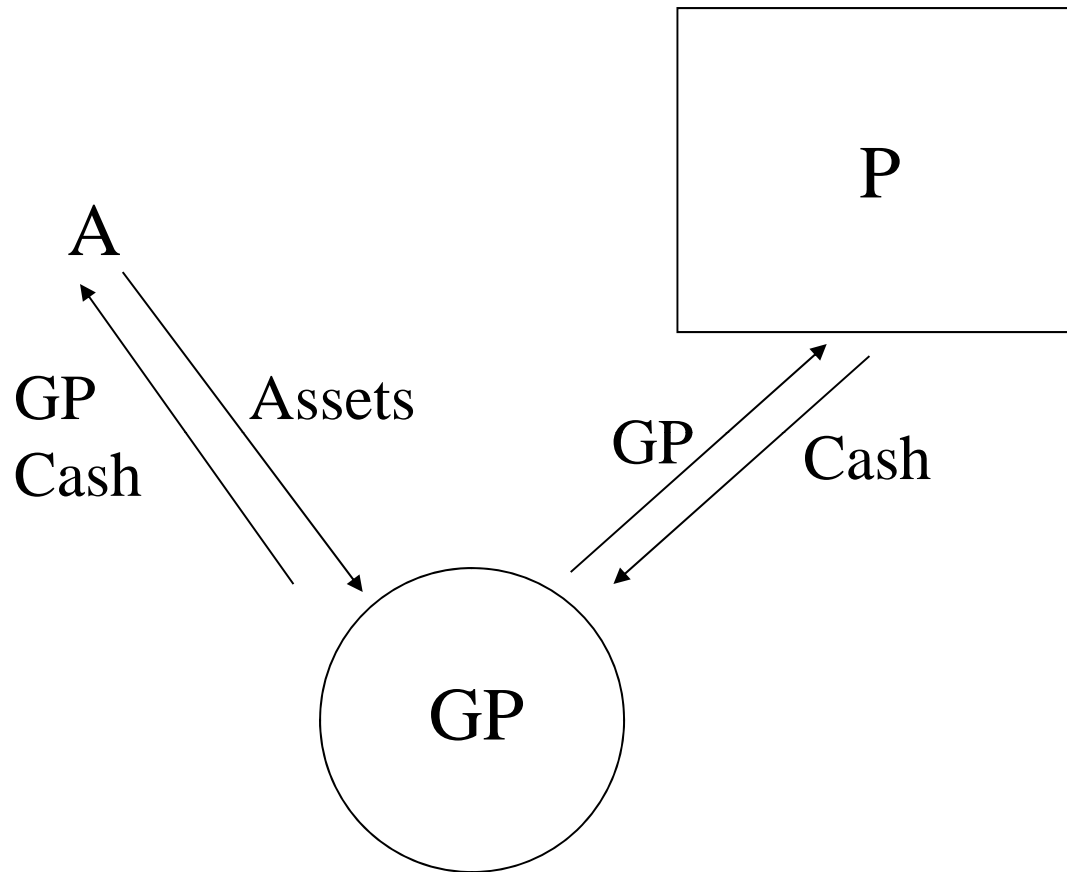

Section 707(a)(2)(B).

## Applicable Asset Acquisition Continued

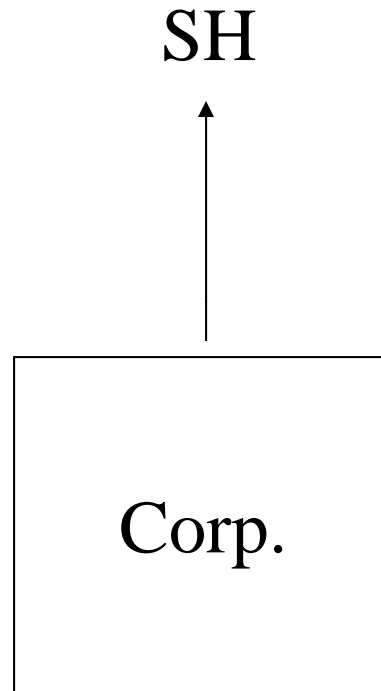

1. Corporation liquidates.
2. Section 302(a) redemption.
3. Section 301 distribution.

# Section 338 Overview

Section 338

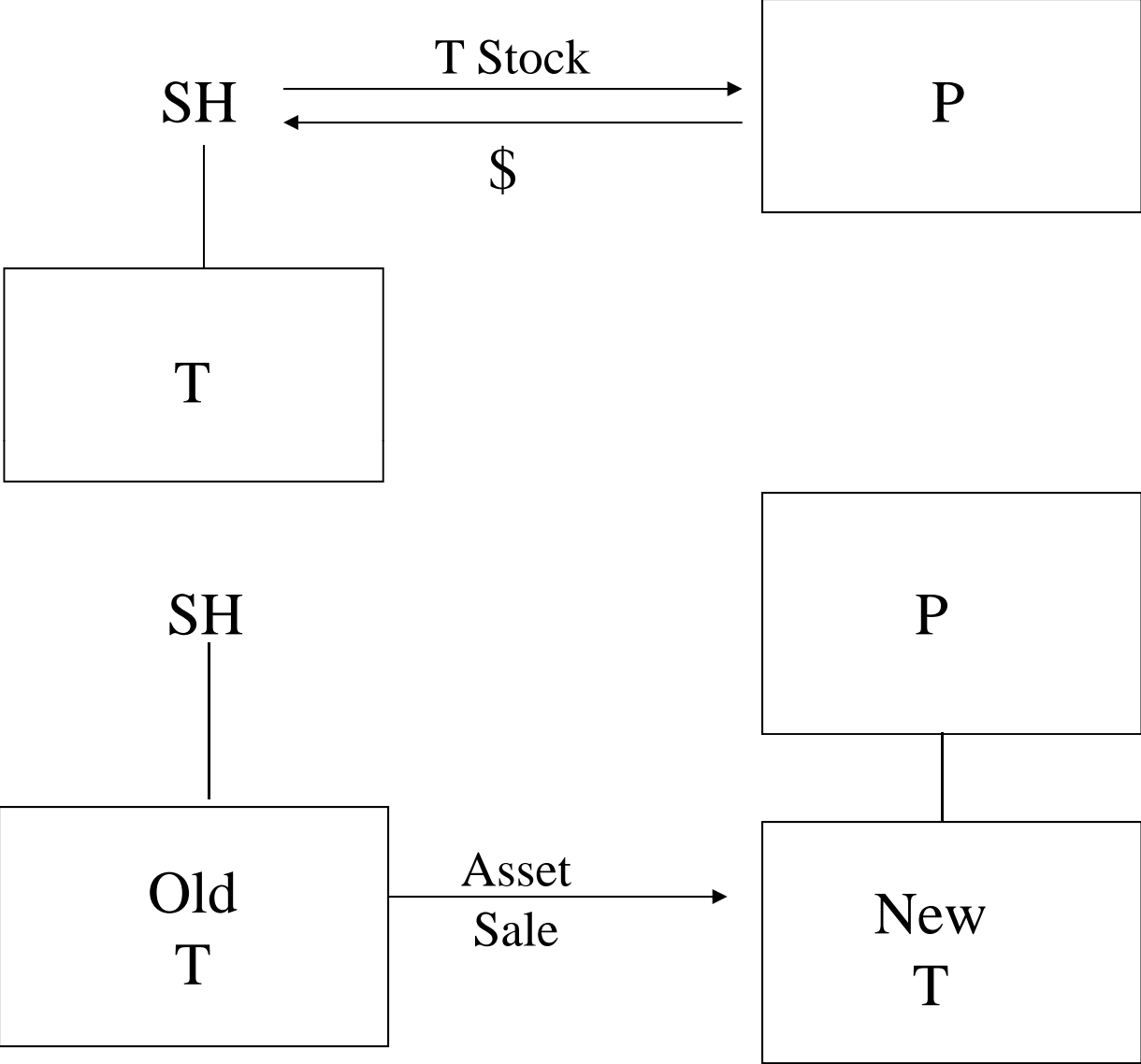



## Section 338(h)(10)

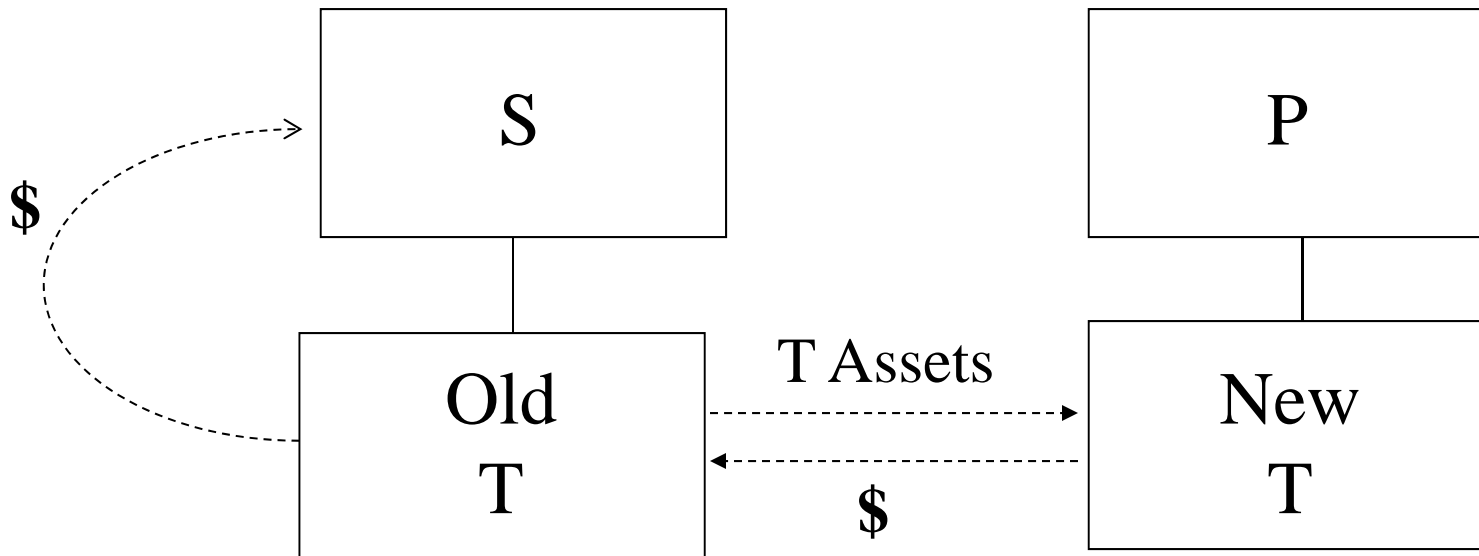
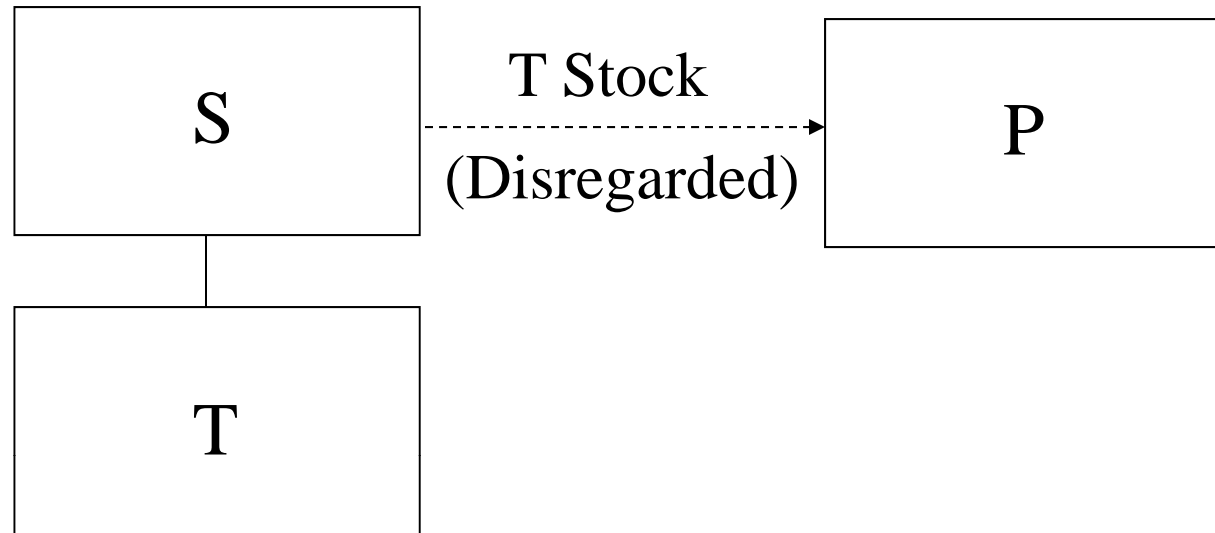

# Section 338 Regulations

## Overview

- The IRS issued final regulations under sections 338 and 1060. T.D. 8940 (February 12, 2001). The final regulations are substantially the same as temporary regulations issued on January 5, 2000 (T.D. 8858), and proposed regulations issued on August 10, 1999 (REG-107069-97, 64 Fed Reg. 43,461).
- The final regulations revise all of the regulations under section 338 other than those dealing with international matters and stock consistency.
- The final regulations are generally effective for qualified stock purchases occurring after March 16, 2001.
- The temporary regulations were generally effective for qualified stock purchases occurring after January 5, 2000 and on or before March 16, 2001.
- The preamble to the proposed regulations provided that the proposed regulations were intended to clarify the treatment of, and provide consistent rules (where possible) for, both deemed and actual asset acquisitions under sections 338 and 1060.

# Section 338 Regulations

## Accounting Rules

- Under the old regulations, the first element in the definition of ADSP was the grossed-up basis of the purchasing corporation's recently purchased T stock. The combination of the link between the definitions of ADSP and AGUB with the rule in the prior regulations that contingent payments are taken into account in AGUB as they become fixed and determinable effectively afforded old T open-transaction treatment. This treatment would not have been available in the case of an actual asset sale.
- The final regulations remove the link between the calculation of the first element of ADSP and the purchaser's basis in recently purchased T stock.
- Under the final regulations ADSP is the sum of:
  - (1) the grossed-up amount realized on the sale to P of P's recently purchased T stock; and
  - (2) the liabilities of old T.
- The amount realized is determined as if old T itself were the selling shareholder. Old T may use the installment method of section 453 in the calculation of the first element of ADSP.

## Section 338 Regulations

### Accounting Rules Continued

- General principles of tax law apply in determining the timing and amount of the elements of ADSP.
- ADSP is redetermined at such time and in such amount as an increase or decrease would be required, under general principles of tax law, to the individual elements of ADSP.
- The same rules apply for purposes of determining (and redetermining) AGUB.
- These changes replace the “fixed and determinable” standard of the old regulations.
- The final regulations make clear that, old T's tax liability incurred on its deemed asset sale is deemed assumed unless the parties have agreed (or the tax or non-tax rules operate such that) the seller, and not T, will bear the economic cost of that tax liability.
- The amount of liabilities of old T taken into account to calculate ADSP is determined as if old T had sold its assets to an unrelated person for consideration that included the unrelated person's assumption of, or taking subject to, the liability.
- In order to be taken into account in AGUB, a liability must be a liability of T that is properly taken into account under general principles of tax law that would apply if new T had acquired its assets from an unrelated person for consideration that included the assumption of, or taking subject to, the liability.

# Section 338 Regulations

## Allocation Rules

- Seven asset classes under the final regulations
  - Class I -- cash and general deposit accounts (including savings and checking accounts) other than certificates of deposit held in banks, savings and loan associations, and other depository institutions.
  - Class II -- actively traded personal property within the meaning of section 1092(d)(1) and Treas. Reg. § 1.1092(d)-1, certificates of deposits, and foreign currency. Class II assets do not include stock of target affiliates, other than actively traded stock described in section 1504(a)(4).
  - Class III -- assets that the taxpayer marks to market at least annually for Federal income tax purposes and debt instruments (including accounts receivable but excluding certain other debt instruments).
  - Class IV -- stock in the trade of the taxpayer or other property of a kind which would properly be included in the inventory of taxpayer if on hand at the close of the taxable year, or property held by the taxpayer primarily for sale to customers in the ordinary course of its trade or business.
  - Class V -- all assets other than Class I, II, III, IV, VI, and VII assets.
  - Class VI -- all section 197 intangibles, as defined in section 197, except goodwill and going concern value.
  - Class VII -- goodwill and going concern value (whether or not the goodwill and going concern value qualifies as a section 197 intangible).

## Treas. Reg. § 1.338-3

### Qualification for the Section 338 Election

- The final regulations include a single definition of purchase applicable to both targets and target affiliates, which definition generally conforms to the definition of purchase of target affiliate in the temporary regulations. Under this definition, stock in a target (or target affiliate) may be considered purchased if, under general principles of tax law, the purchasing corporation is considered to own the stock of the target (or the target affiliate) meeting the requirements of section 1504(a)(2), notwithstanding that no amount may be paid for (or allocated to) the stock. See Treas. Reg. § 1.338-3(b)(2).
- For purposes of determining whether the parties are related at the time of the purchase of the T stock, the relationship between the purchaser and seller is tested immediately after the transaction. See Treas. Reg. § 1.338-3(b)(3)(ii).

# Treas. Reg. § 1.338(h)(10)-1

## Deemed Asset Sale and Liquidation

- Treas. Reg. § 1.338(h)(10)-1 describes the model on which taxation of the section 338(h)(10) election is based. Under the final regulations:
  - (1) Old T is treated as transferring all of its assets by sale to an unrelated person.
  - (2) Old T recognizes the deemed sale gain while a member of the selling consolidated group, or owned by the selling affiliate, or owned by the S corporation shareholders (both those who actually sell their shares and any who do not).
  - (3) Old T is then treated as transferring all of its assets to members of the selling consolidated group, the selling affiliate, or S corporation shareholders and ceasing to exist.
  - (4) If T is an S corporation, the deemed asset sale and deemed liquidation are considered as occurring while it is still an S corporation.
- The preamble to the proposed regulations states that the proposed regulations treat all parties concerned as if the transactions that are deemed to occur under section 338(h)(10) actually did occur, or as closely thereto as possible.
- Old T generally may not obtain any tax benefit from the section 338(h)(10) election that it would not obtain if it actually sold the assets and liquidated. Treas. Reg. § 1.338(h)(10)-1(d)(9).

## Treas. Reg. § 1.338(h)(10)-1

### Deemed Asset Sale and Liquidation Continued

- When T is an S corporation, any qualified subchapter S subsidiaries under section 1361(b)(3) remain qualified subchapter S subsidiaries through the close of the acquisition date. No similar rule applies when a qualified subchapter S subsidiary, as opposed to the S corporation that is its owner, is the target the stock of which is actually purchased. Treas. Reg. § 1.338(h)(10)-1(d)(3).
- In the case of parent-subsidary chains of corporations making section 338(h)(10) elections, the deemed asset sale at the parent level is considered to precede that at the subsidiary level. Treas. Reg. § 1.338(h)(10)-1(d)(3)(ii).
- However, the deemed liquidation of the subsidiary is considered to precede the deemed liquidation of the parent. Treas. Reg. § 1.338(h)(10)-1(d)(4)(ii).
- The regulations make the section 453 installment method available to old T in its deemed asset sale, as long as the deemed asset sale would otherwise qualify for installment sale reporting. Treas. Reg. § 1.338(h)(10)-1(d)(8).
- The regulations remove the term MADSP from the regulations and extend the use of the term “aggregate deemed sales price” or “ADSP” generally applicable to section 338 transactions to section 338(h)(10). The "other relevant items" included in the calculation of MADSP are not included in the calculation of ADSP.



## Reporting Requirements

- Forms 8023 and 8883
  - Form 8023 is used to make an election under section 338.
    - A purchasing corporation makes a section 338(g) election by filing a Form 8023.
    - If a section 338(h)(10) election is made, Form 8023 must be filed jointly by the purchasing corporation and the common parent of the selling affiliated group (or the selling affiliate or S corporation shareholder(s)).
  - Form 8883, “Asset Allocation Statement under Section 338,” must also be filed to supply information relevant to the election.
    - For elections under section 338(h)(10), both the old and new target corporation must file Form 8883.

# Purchase

# Section 338 Regulations

- Definition of “Purchase”
  - The regulations include a single definition of purchase applicable to both targets and target affiliates. Under this definition, stock in a target (or target affiliate) may be considered purchased if, under general principles of tax law, the purchasing corporation is considered to own the stock of the target (or the target affiliate) meeting the requirements of section 1504(a)(2), notwithstanding that no amount may be paid for (or allocated to) the stock.
  - Section 338(h)(3)(A) defines the term "purchase" as "any acquisition of stock," subject to the following conditions:
    - The basis of the T stock in the hands of P is not determined (i) in whole or part by reference to the adjusted basis of such stock in the hands of T's former shareholders, or (ii) under section 1014(a) (property acquired from a decedent);
    - The T stock is not acquired in an exchange to which section 351, 354, 355 or 356 applies or in any other transaction described in the regulations in which the transferor recognizes less than all of its realized gain or loss; and
    - The T stock is not acquired from a person the ownership of whose stock would, under section 318(a) (other than paragraph (4) -- the option attribution provision), be attributed to P. The regulations provide that the relationship between the purchaser and seller is tested immediately after the transaction. See Treas. Reg. § 1.338-3(b)(3)(ii).
  - Treas. Reg. § 1.338-3(b)(1)
    - “An individual cannot make a qualified stock purchase of target. Section 338(d)(3) requires, as a condition of a qualified stock purchase, that a corporation purchase the stock of target. If an individual forms a corporation (new P) to acquire target stock, new P can make a qualified stock purchase of target if new P is considered for tax purposes to purchase the target stock. Facts that may indicate that new P does not purchase the target stock include new P's merging downstream into target, liquidating, or otherwise disposing of the target stock following the purported qualified stock purchase.”

## Section 338 -- Purchase

### Has a Corporation Made the Purchase

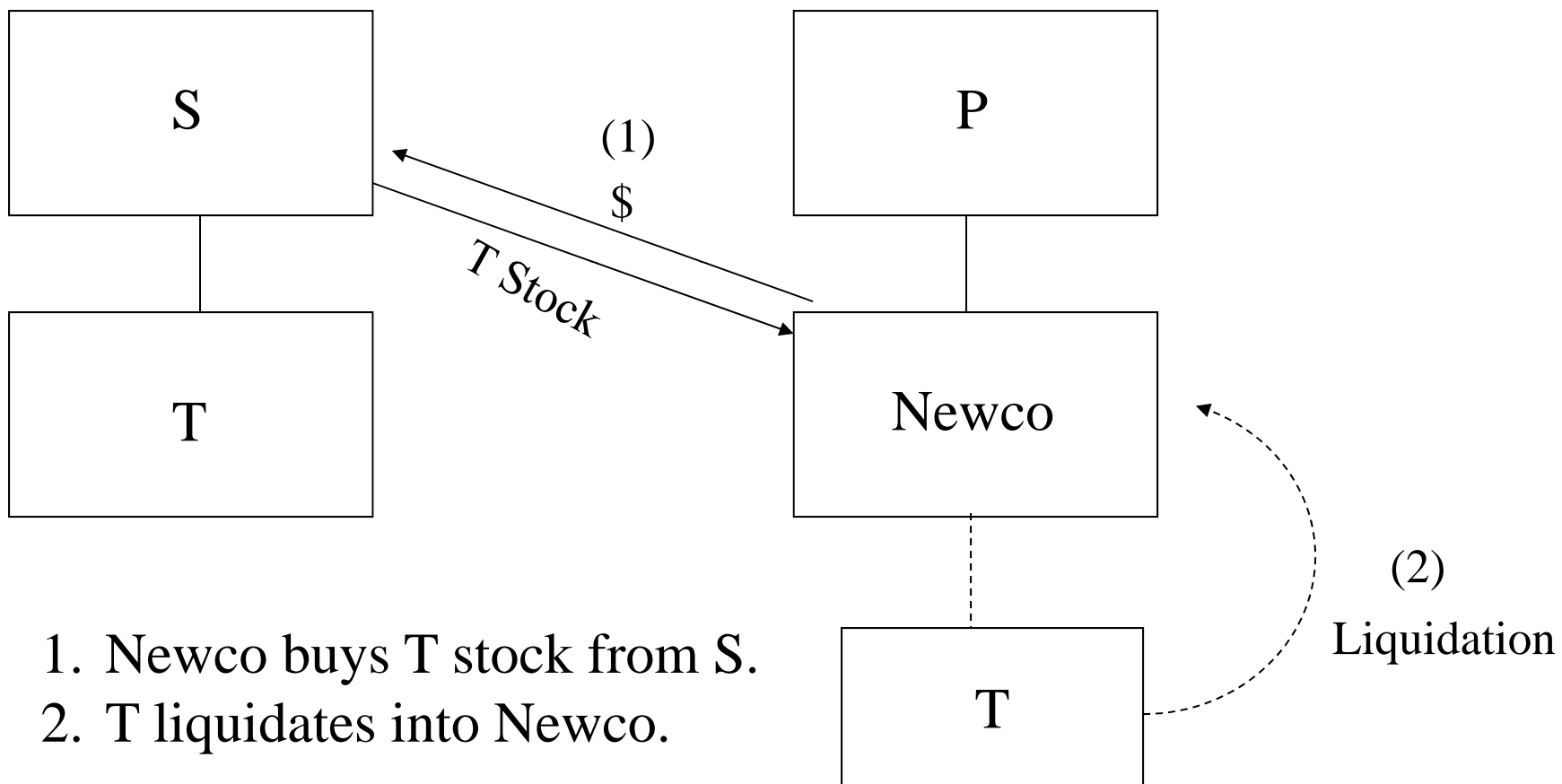

## Section 338 -- Purchase

### Has a Corporation Made the Purchase Continued

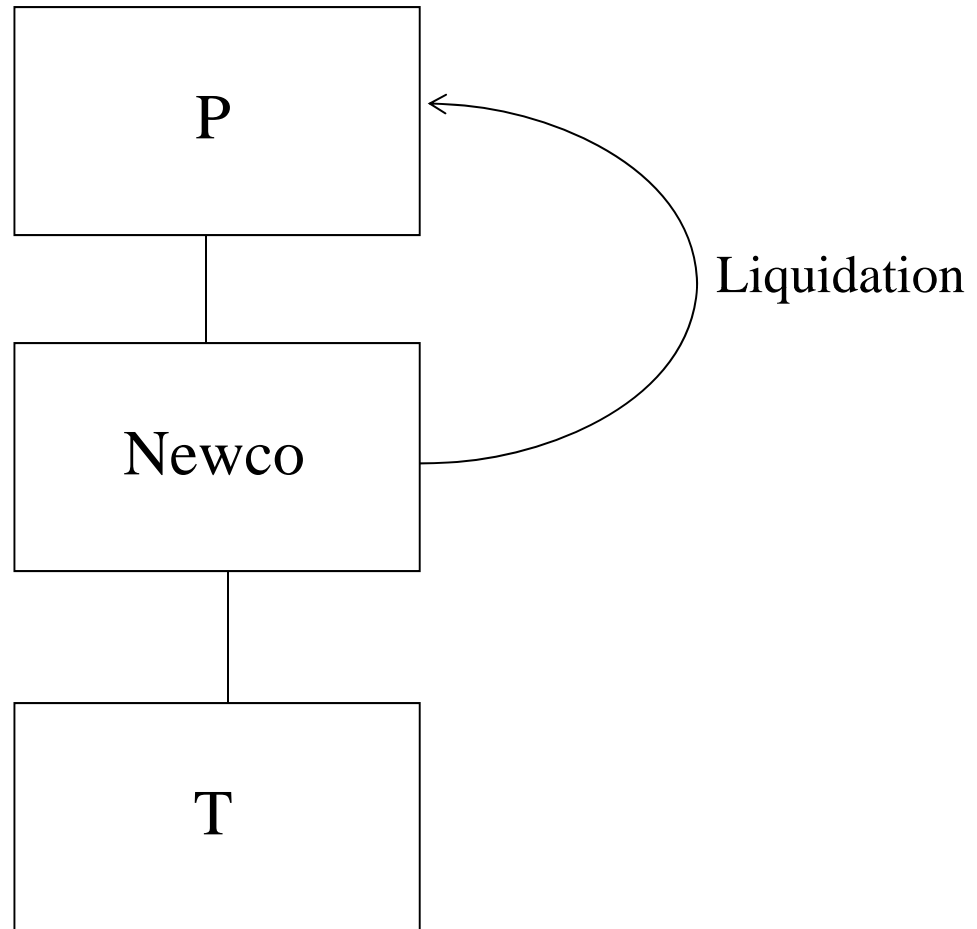

Alternative:

2. Newco is liquidated into P.

## Section 338 -- Purchase

### Has a Corporation Made the Purchase Continued

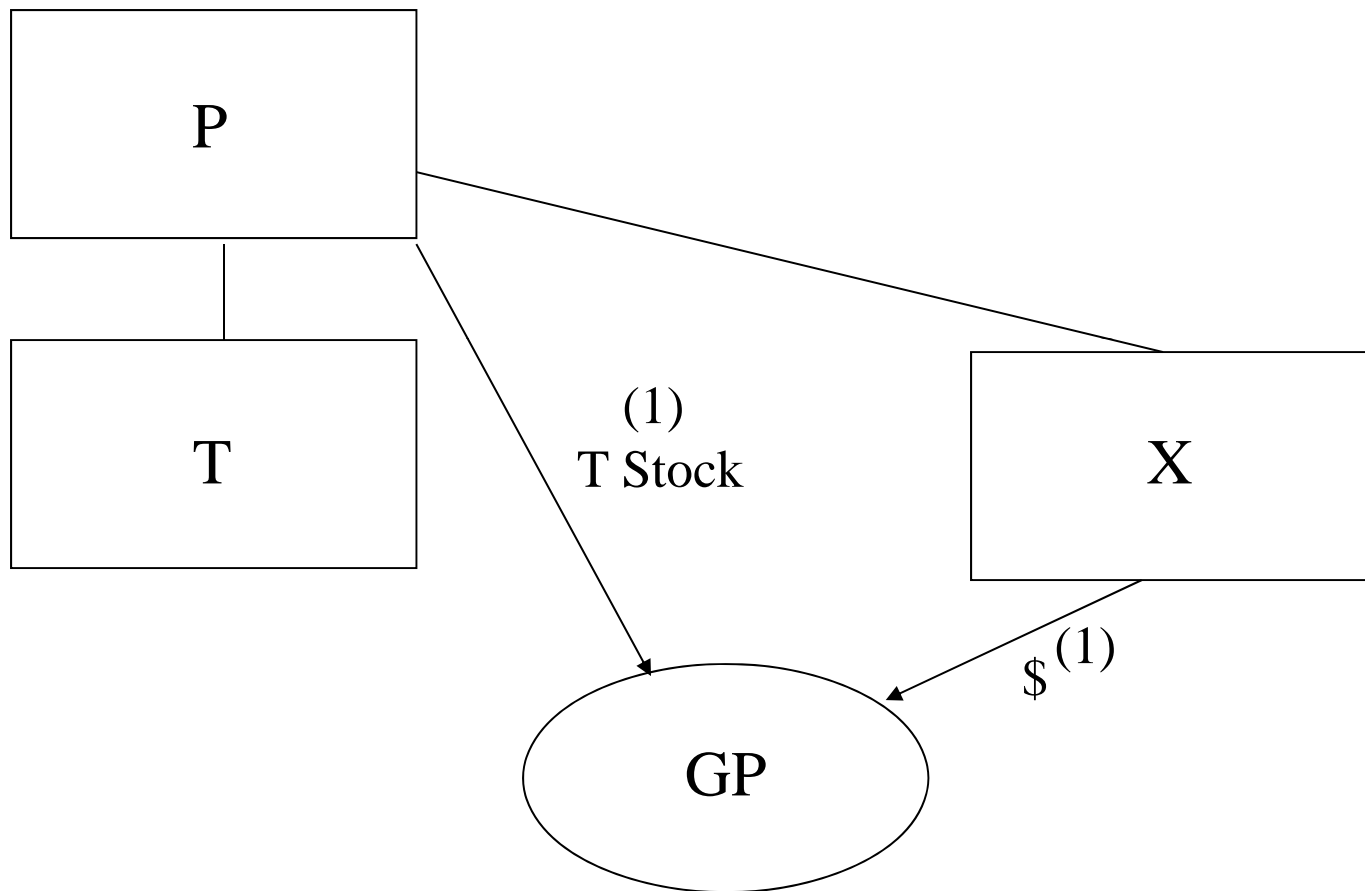

P and X form a partnership. P transfers the T stock to the partnership.

## Section 338 -- Purchase

### Has a Corporation Made the Purchase Continued

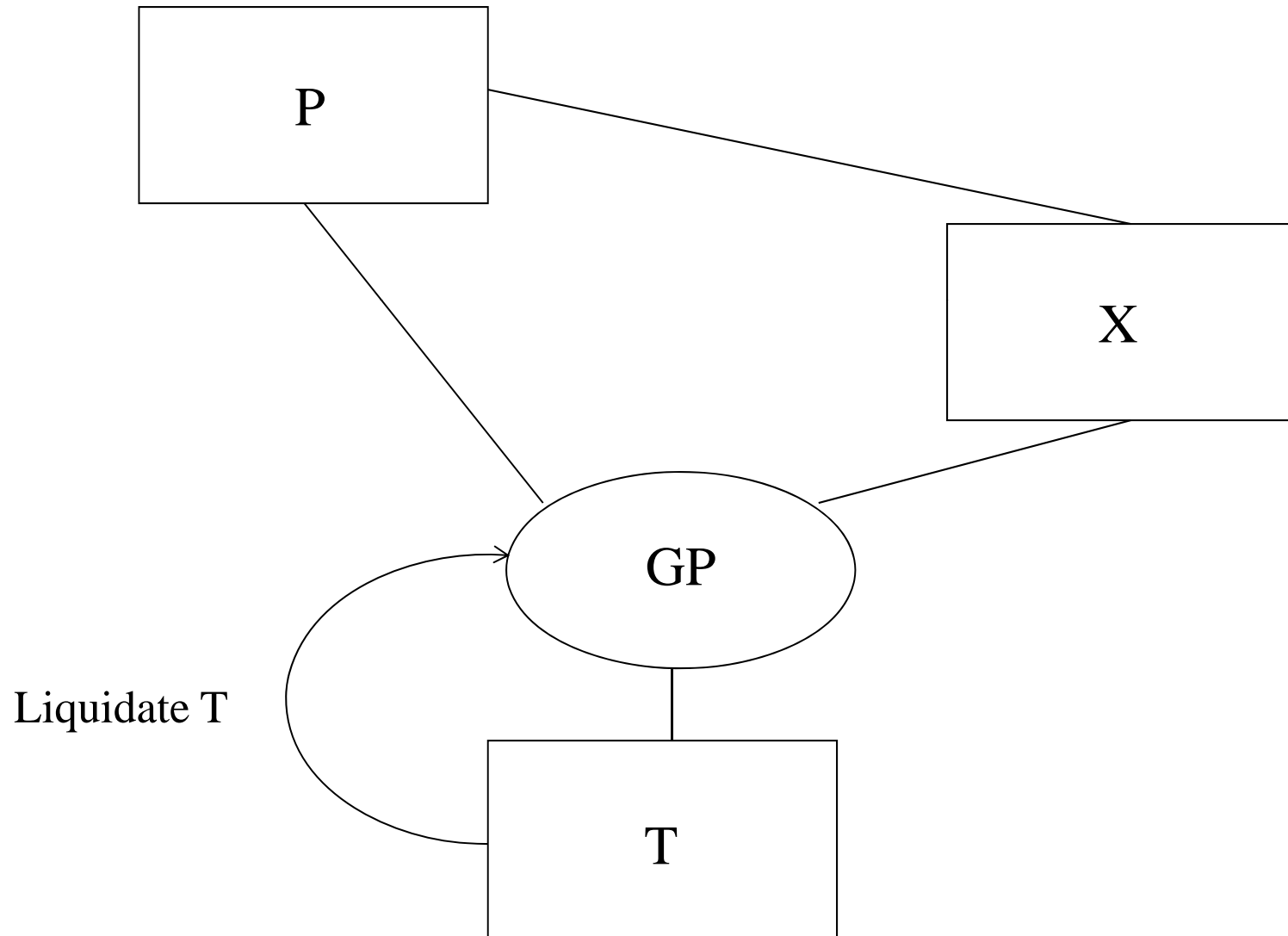

## Section 338 -- Purchase Has a Corporation Made the Purchase

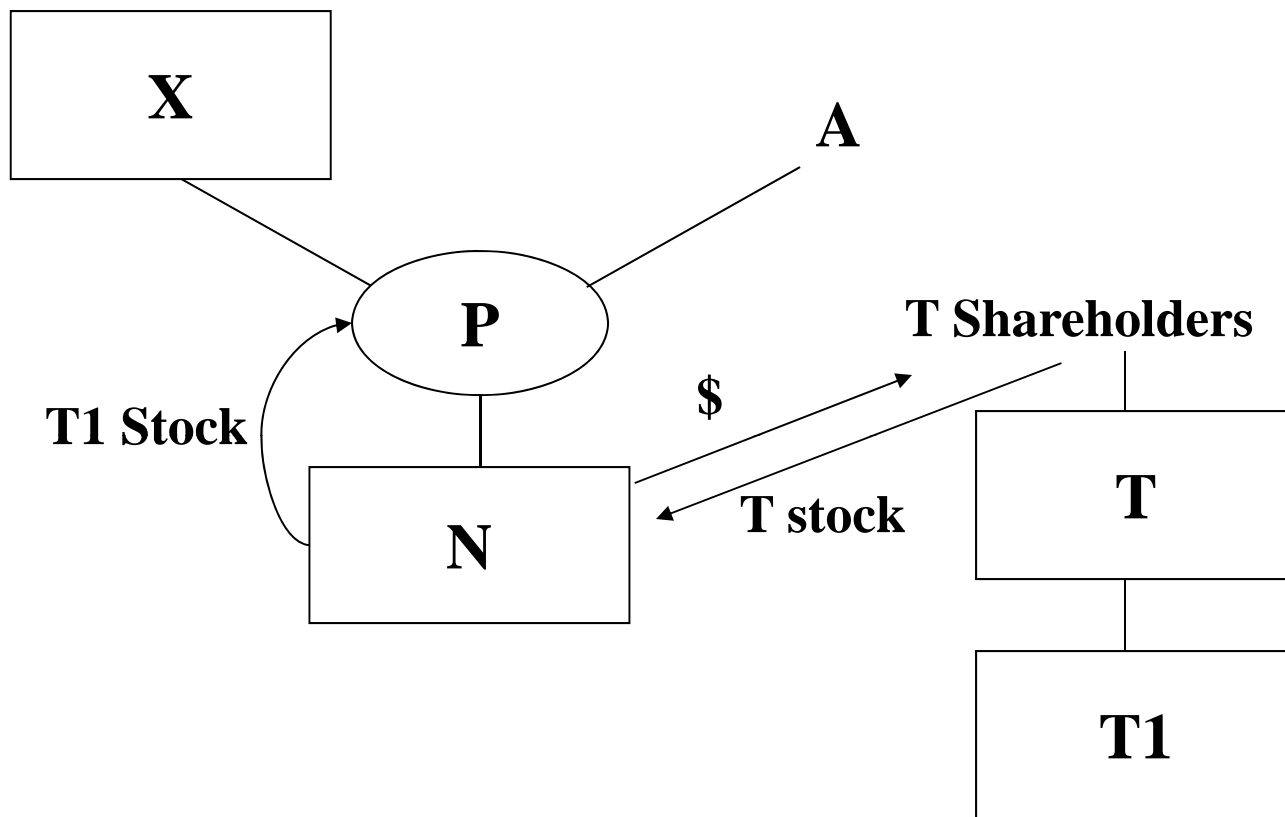

Facts: Corporation X and Individual A own Partnership P. Corporation T's only asset is 100% of the stock of T1. T1 owns intellectual property. P wishes to acquire the stock of T1 and achieve a step-up in the basis of T1's assets. P forms Newco N, which acquires 100% of the T stock in a QSP. A section 338 election is made for both T and T1. Immediately thereafter, T distributes the T1 stock to N, which in turn distributes the T1 stock to P.

Question: Has a "purchase" been made? See PLR 200122007 (Feb. 13, 2001); Treas. Reg. § 1.338-3(b)(1).



# Section 338 -- Purchase Contemporaneous Sale of Affiliate Stock

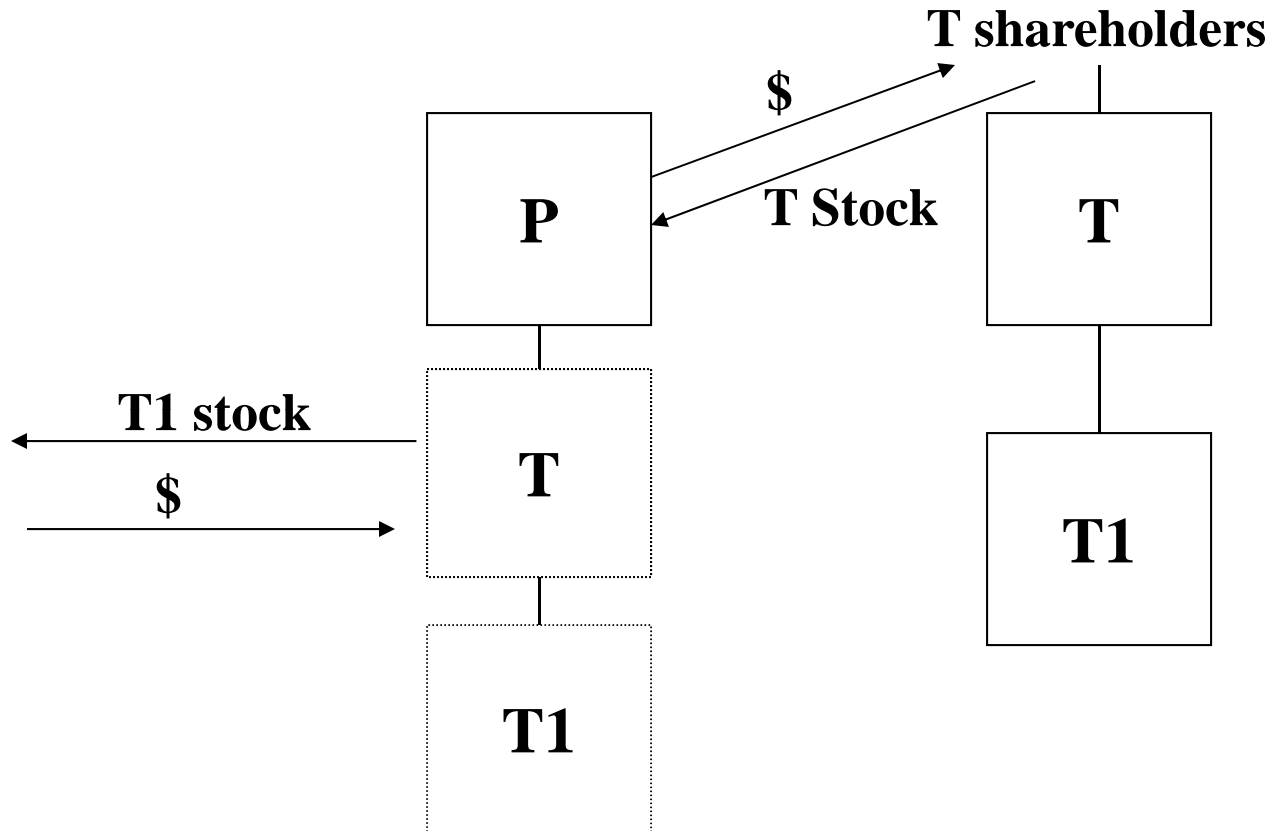

Facts: P purchases 100% of the stock of T and makes a section 338 election for T. Before the close of the day, P causes T to sell all of the T1 stock to a third party.

Question: Is T considered to have purchased the stock of T1 prior to the sale of T1 stock? See Treas. Reg. § 1.338-1(d); Former Temp. Treas. Reg. § 1.338-3T(b)(4)(ii) Ex. 2; Treas. Reg. § 1.338-3(b)(1).

## Section 338 -- Purchase

### Common Ownership of S and P

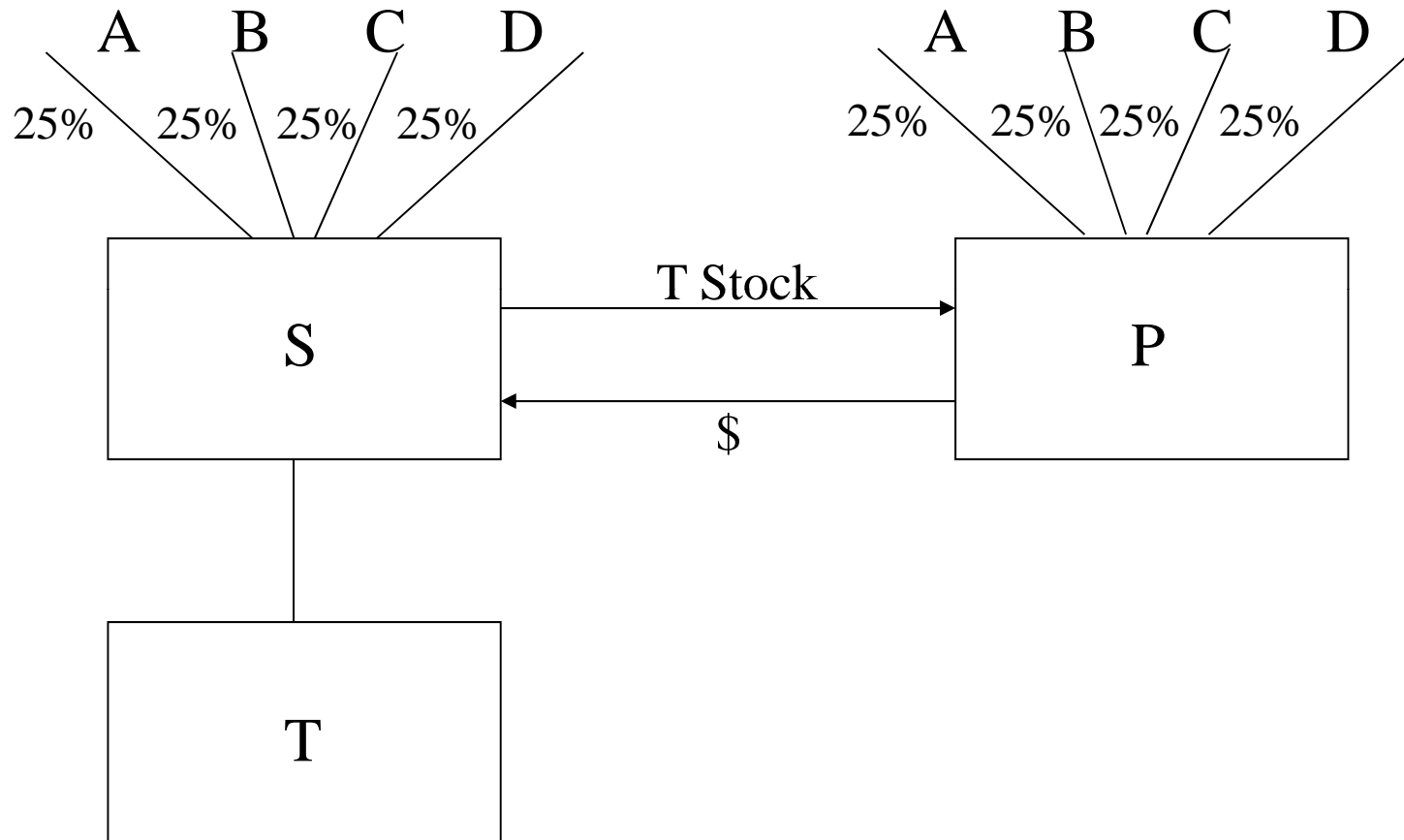

Has P purchased the T stock?

## Section 338 -- Purchase Cash Investment

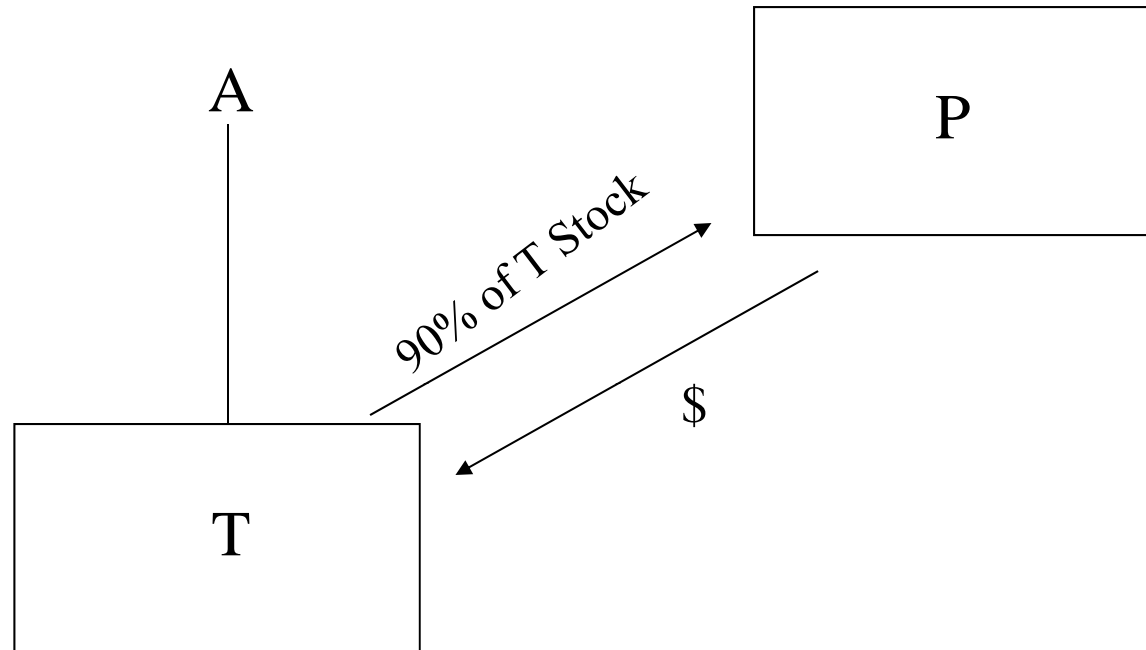

1. A owns all T stock.
2. P transfers cash to T for 90% of T stock.
3. Has P purchased the T stock?
4. What if T also has non-voting preferred stock that is not bought?

## Section 338 -- Purchase

### Cash Investment Followed by Redemption

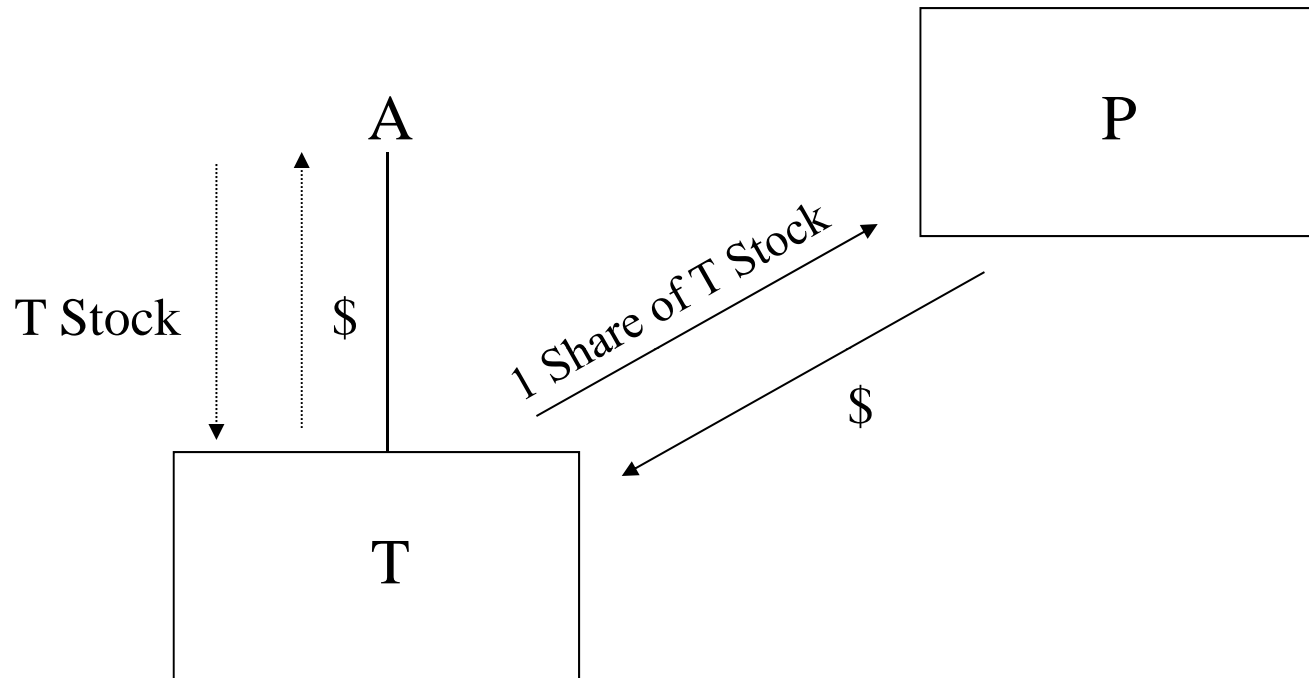

1. A owns all T stock.
2. P transfers cash to T for 1 share of T stock.
3. A is redeemed by T (using funds other than those provided by P.)
4. Has P purchased the T stock?

## Section 338 -- Purchase

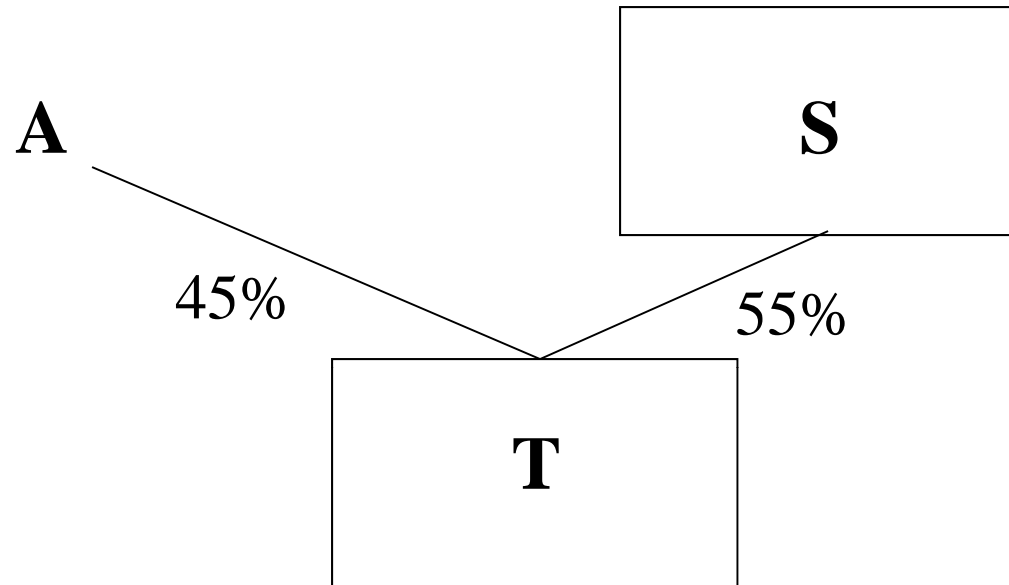

1. T redeems S's T stock, and S purchases A's T stock.
2. Recap S's T stock to section 1504(a)(4) preferred stock and then S purchases A's T stock
3. S sells T stock to P and then S buys T stock from A and P

Are any of these transactions Qualified Stock Purchases?

## Qualified Stock Purchase -- Effect of Section 351

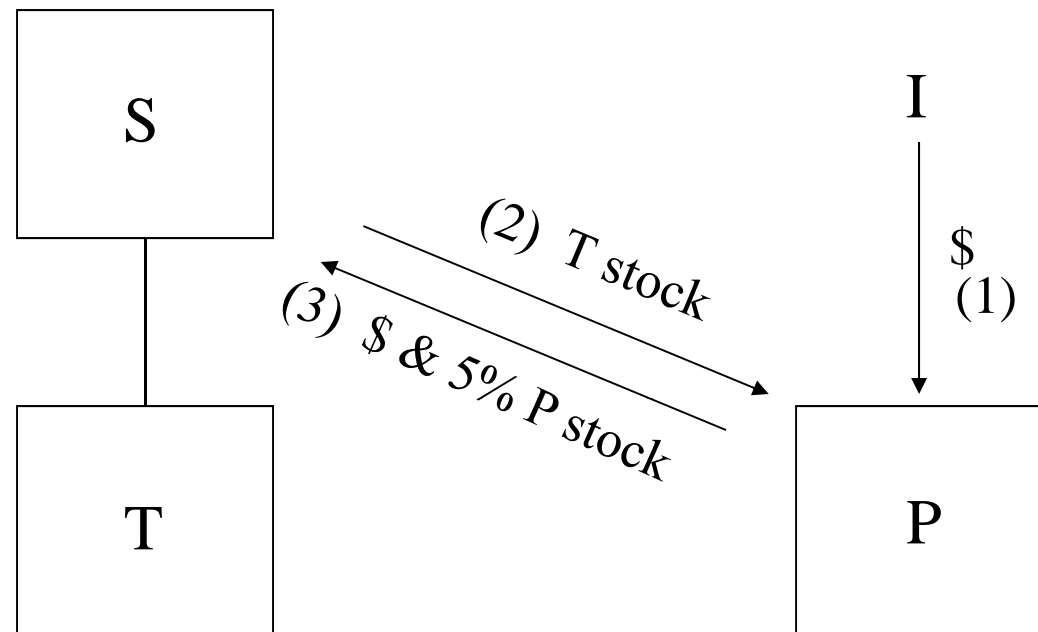

1. Investor (“I”) transfers cash to Newco (“P”)
2. S transfers T stock to P.
3. P transfers cash and 5% of P stock to S.

# Qualified Stock Purchase -- Effect of Section 351

## Continued

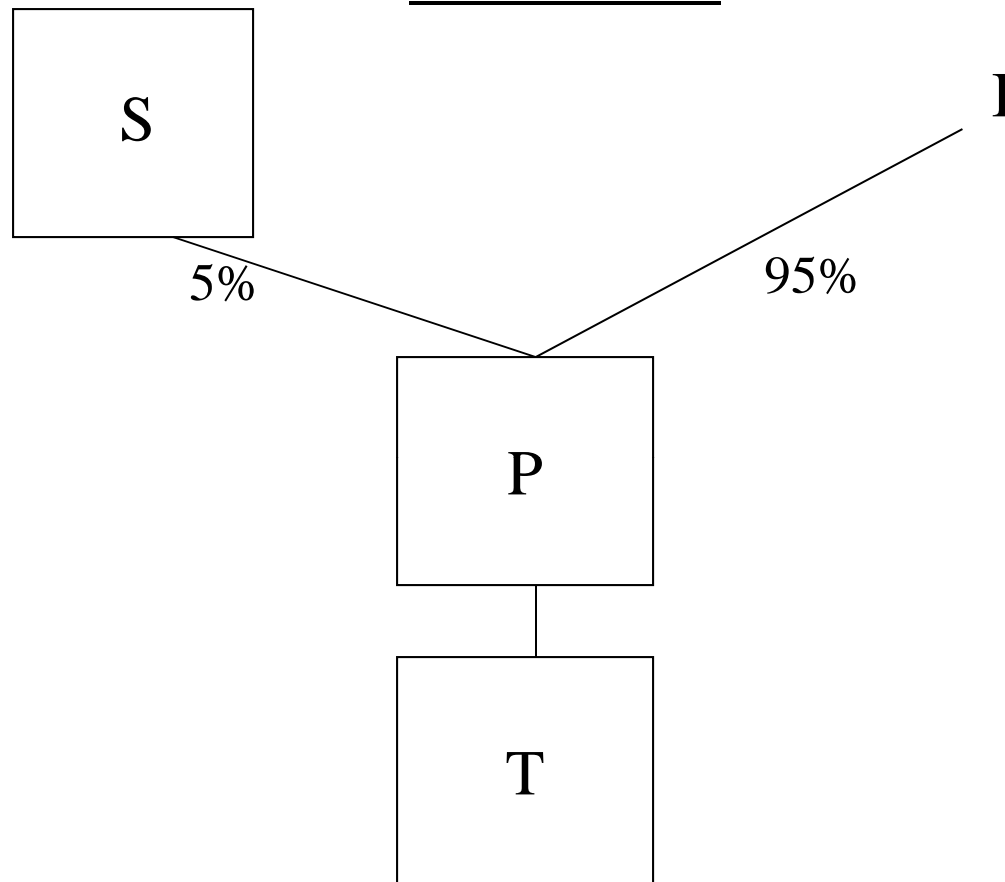

## Variations

- S is several individuals, some shareholders sell P stock, while others do not.
- The transaction is leveraged.

## Qualified Stock Purchase -- Section 351 Continued

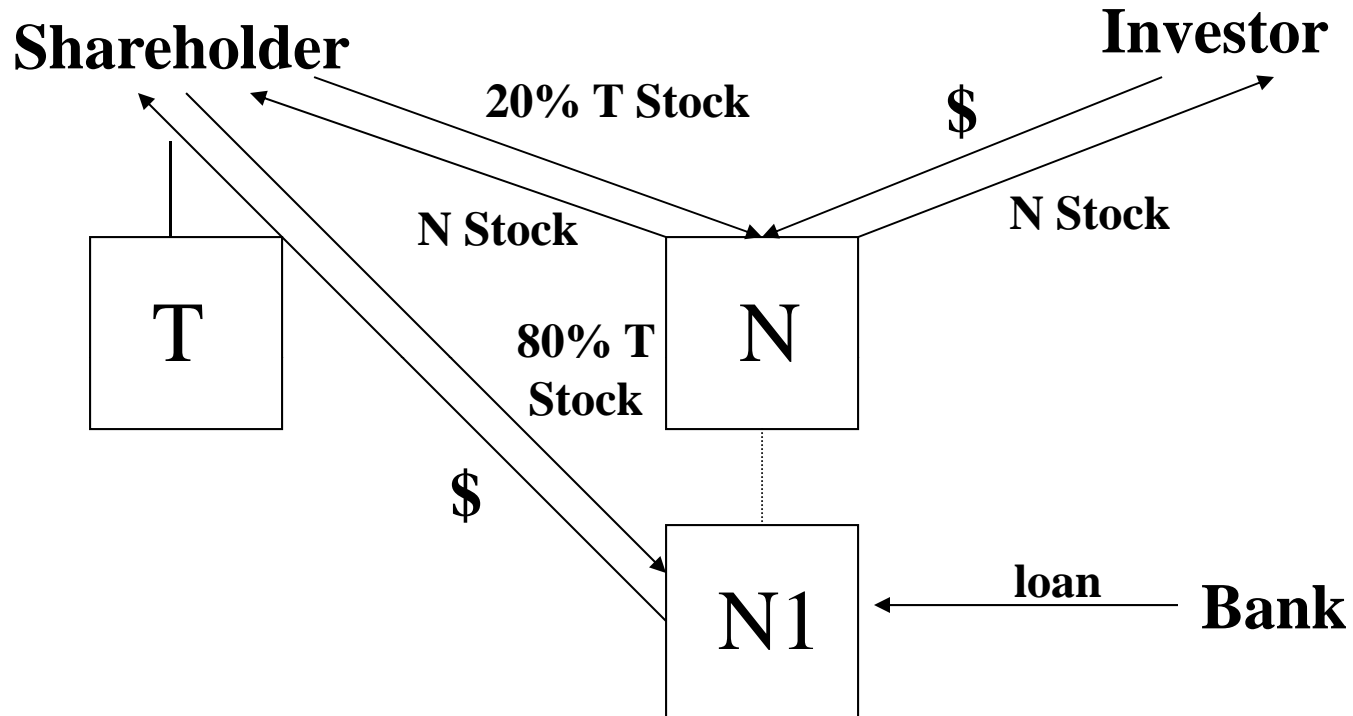

**Facts:** Shareholder contributes 20 percent of the T stock to N in exchange for N stock, and Investor contributes cash to N in exchange for N stock. N forms N1. N borrows money from Bank. Shareholder sells 80 percent of the T stock to N1 in exchange solely for cash.

**Issues:** Is the acquisition by N1 of T stock a qualified stock purchase transaction? How is N's non-purchased stock treated?



## Qualified Stock Purchase

## Section 338 -- Purchase

### Has a Corporation Made a Qualified Stock Purchase

- Section 338(d)(3)
  - “The term ‘qualified stock purchase’ means any transaction or series of transactions in which stock (meeting the requirements of section 1504(a)(2)) of 1 corporation is acquired by another corporation by purchase during the 12-month acquisition period.”

# Section 338 -- Qualified Stock Purchase Target Stock Owned by Subsidiary

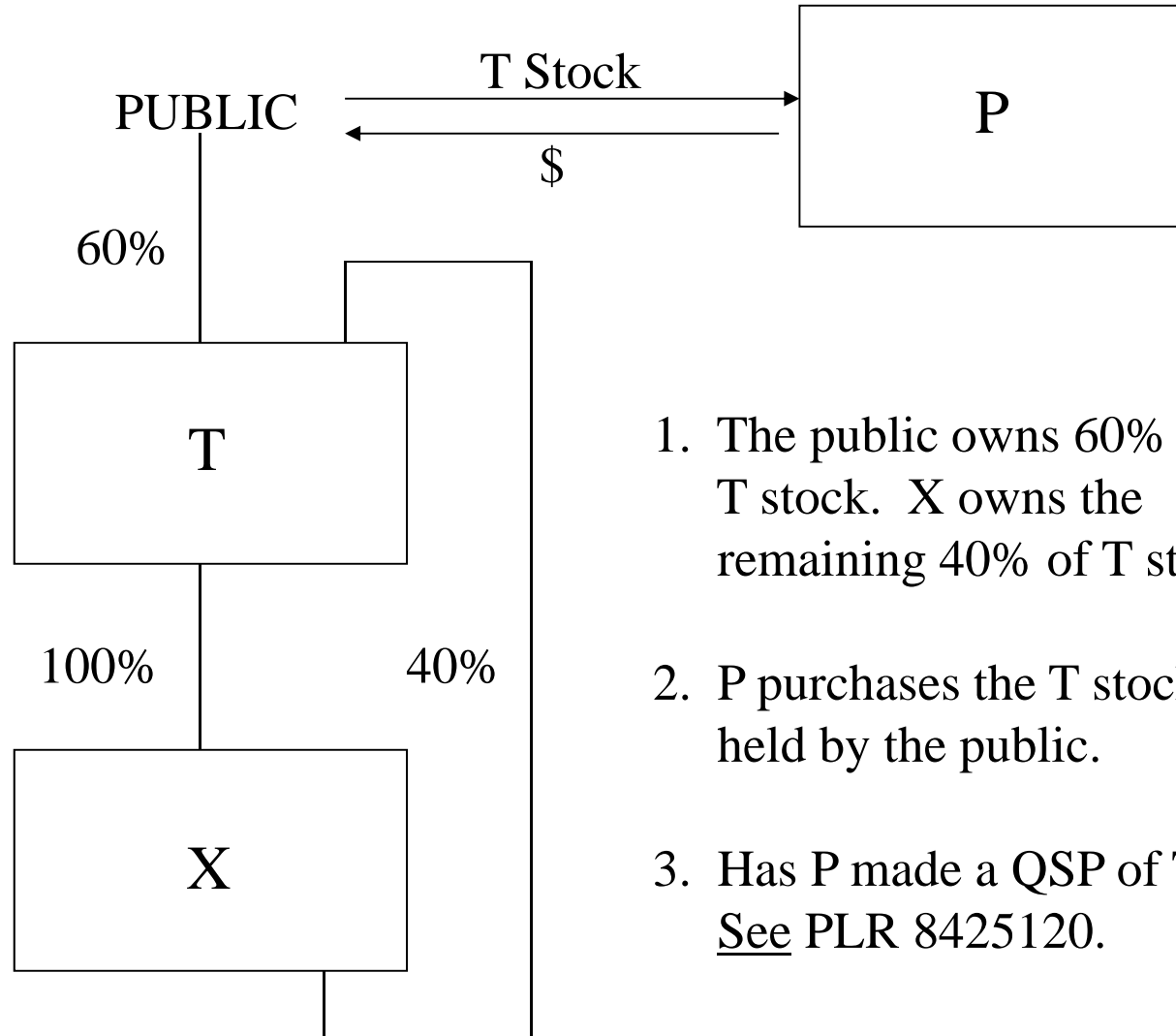

1. The public owns 60% of T stock. X owns the remaining 40% of T stock.
2. P purchases the T stock held by the public.
3. Has P made a QSP of T?  
See PLR 8425120.

## Acquisition of Partnership Interests

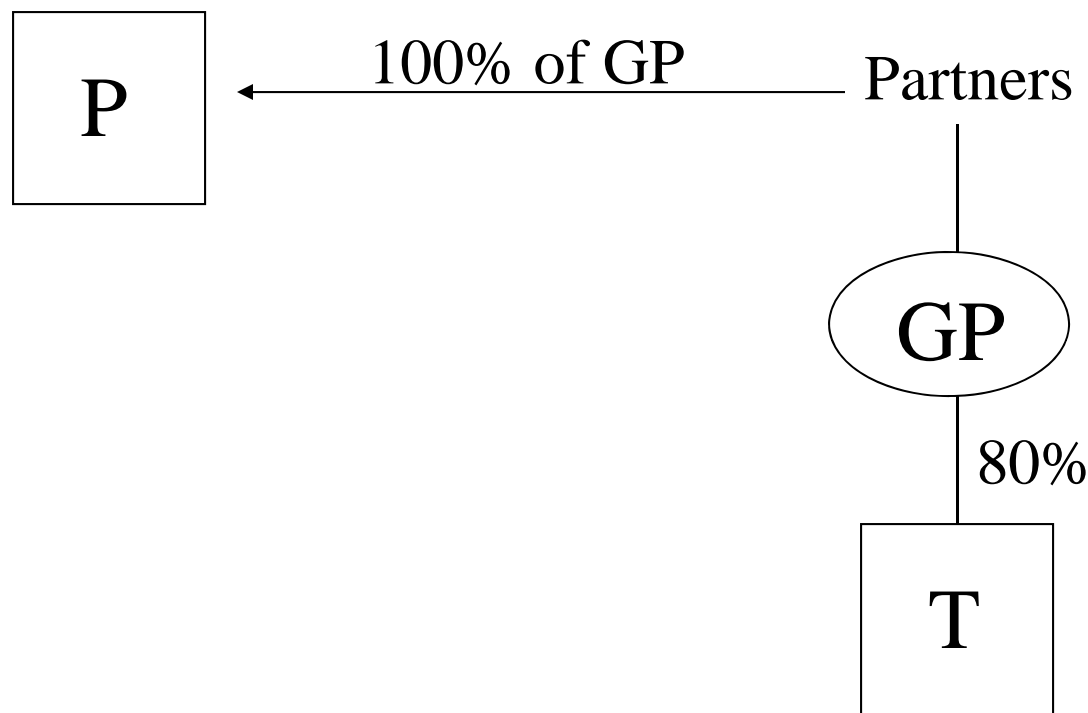

**Facts:** GP owns 80 percent of the stock of Target T. P acquires 100 percent of the partnership interests of GP.

**Question:** Has P made a QSP of T? See Rev. Rul. 99-6, 1 C.B. 432 (situation 2).

# PLR 201002031 – Section 338

## Sale of Stock by Nonresident

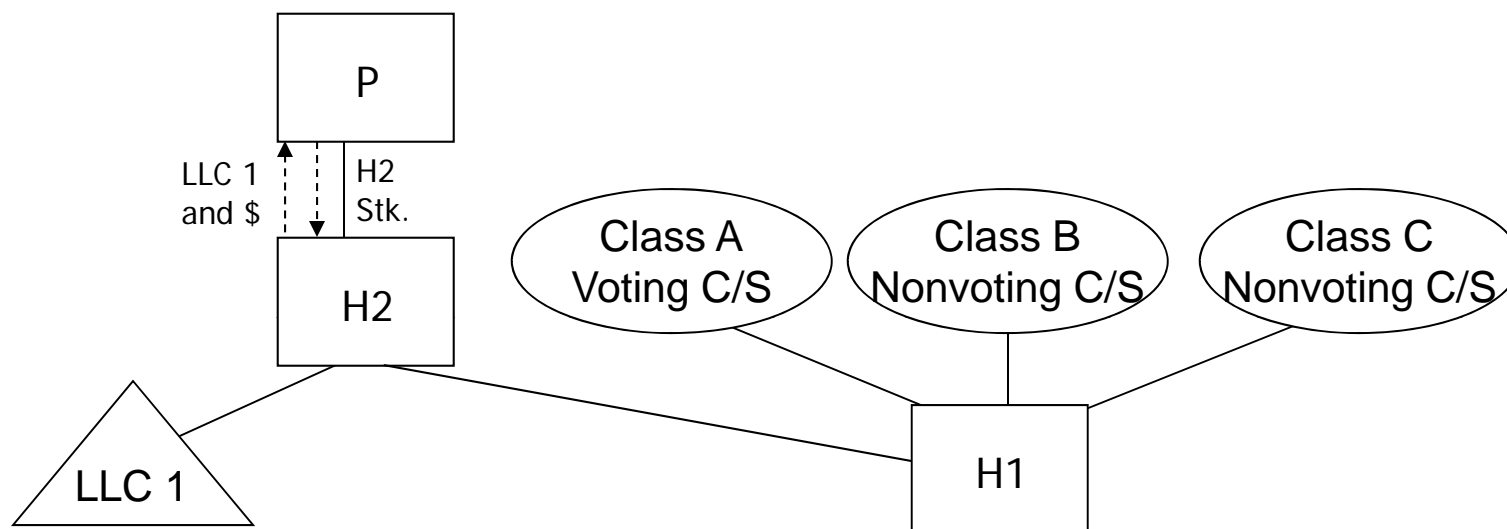

- Step 1: Holding 2 transfers cash and all of its interest in LLC 1 to Parent in redemption of an equal amount of Holding 2 stock.

# PLR 201002031 – Section 338

## Sale of Stock by Nonresident

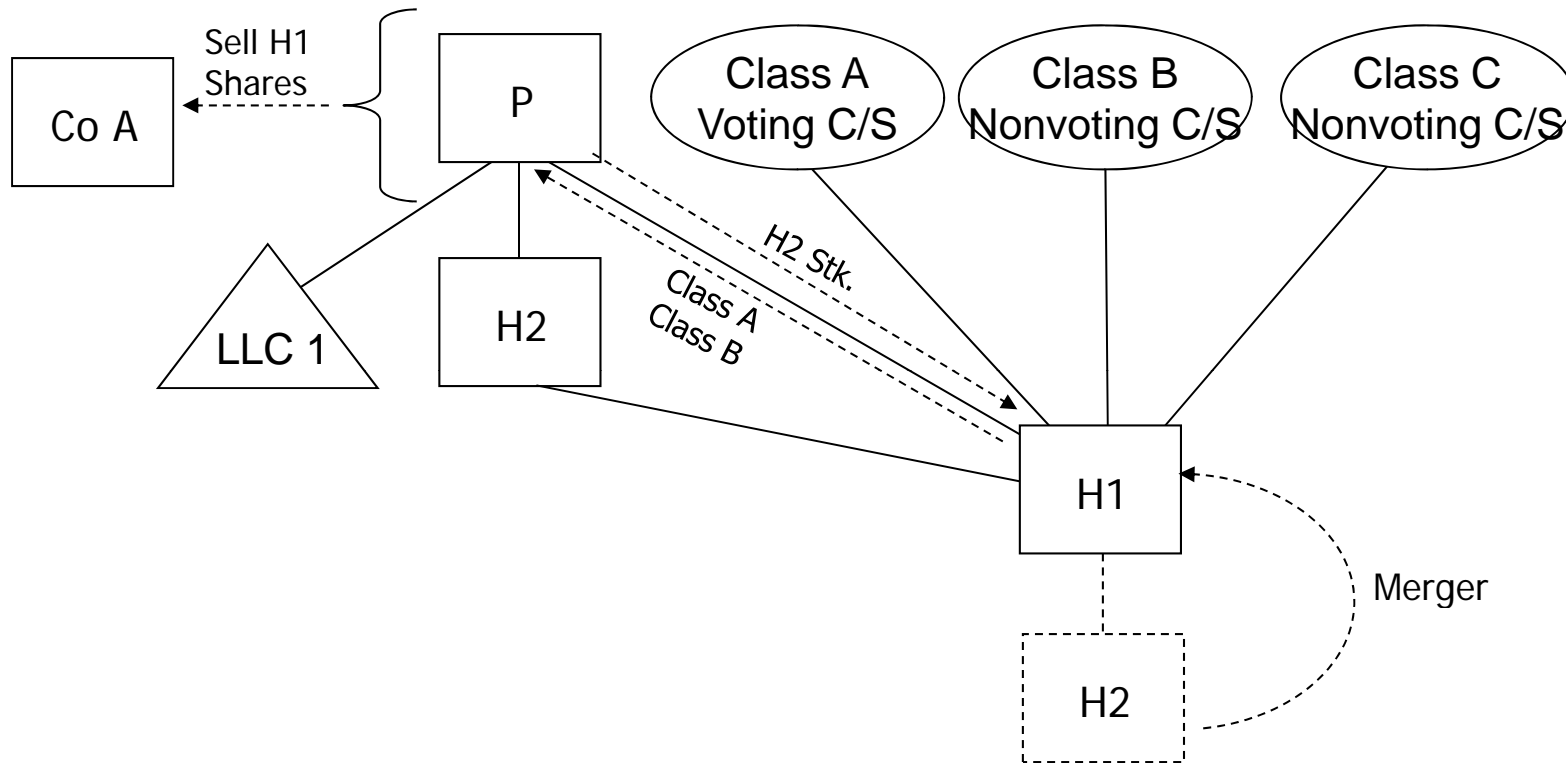

- Step 2: Parent exchanges all of the stock of Holding 2 for Class A C/S and Class B Nonvoting C/S of Holding 1.
- Step 3: Holding 2 merges upstream into Holding 1.
- Step 4: Foreign Company A purchases for cash all of the outstanding shares of Holding 1 from Holding 1's shareholders.

# PLR 201002031 – Section 338

## Sale of Stock by Nonresident

- IRS Ruling:
  - Acquisition of stock of Holding 1 by Holding 2 treated as qualified stock purchase within meaning of Section 338(d)(3) since acquisition does not meet requirements for reorganization treatment.
  - The merger of Holding 2 with and into Holding 1 deemed complete liquidation within meaning of Section 332.
- Comment: The PLR contained the following representation –
  - There was no reduction in the fair market value of the c shares of Holding 1 Class A common stock owned by Holding 2 immediately prior to the Exchange as a result of the Exchange and the issuance of the h shares of Holding 1 Class A common stock and the I shares of Holding 1 Class B common stock by Holding 1 to Parent in the Exchange.
- *See also* PLR 200945004.

## PLR 201003012 – ‘D’ and ‘F’ Reorganizations Internal Corporate Combination

- IRS rules that the Oldco transactions are a type-F reorganization.
- IRS rules that Oldco’s NOLs are subject to SRLY in Newco consolidated group, and Oldco group terminates under Reg. §§ 1.1502-13 and 1.1502-19.
- IRS rules that the T transactions are an acquisitive type-D reorganization and reverse acquisition by Newco.
- IRS rules that T’s NOLs are not subject to SRLY in Newco consolidated group.
- Since T is larger than Oldco, why is the Oldco transaction (and not the T transaction) the type-F reorganization?



# Qualified Stock Purchase -- Top-Up Option

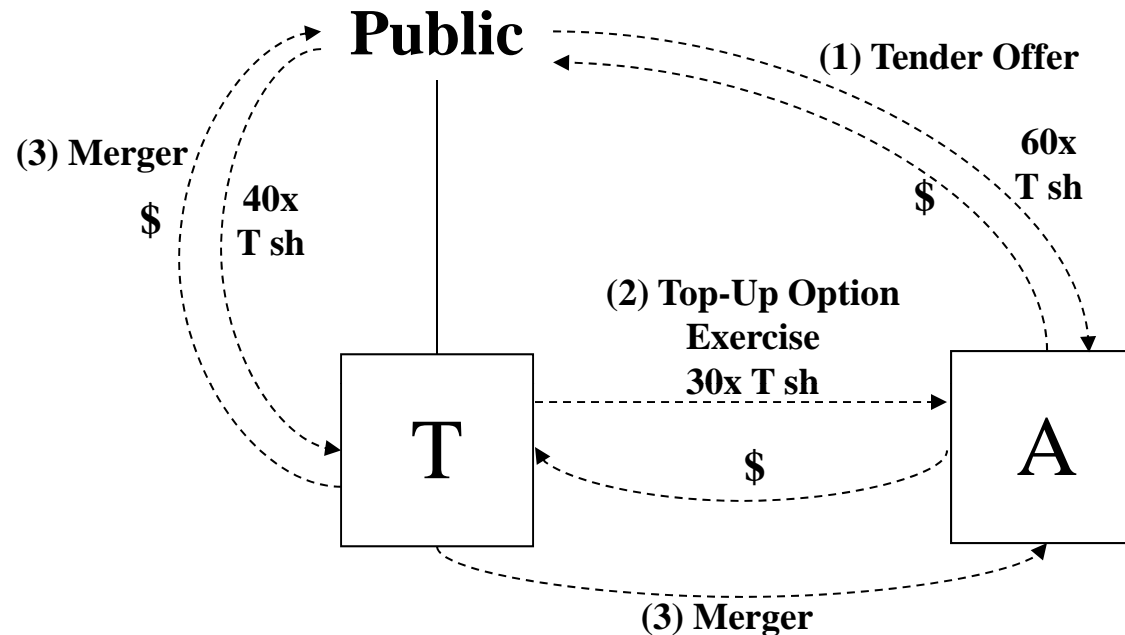

- By agreement to complete A's acquisition of unrelated T—
  - 1) In a tender offer, 60x of the 100x outstanding T shares are tendered to A.
  - 2) A exercises a "top-up option" and buys 300x newly-issued shares of T stock from T for cash, so that A holds 90% of the T stock (360x/400x shares) -- enough to effect a short-form squeeze-out merger).
  - 3) T merges into A. The cash used by A to exercise the top-up option is used to cash out the remaining 40x shares of T stock, and the remainder of the cash is returned to A.
- Is the acquisition a qualified stock purchase? Why might it matter?
- Would the answer change if—
  - 1) A's parent, P, provides the cash to exercise the top-up option, and
  - 2) The extra cash is not returned to P but is used to pay down historic T debt?

# PLR 201126003

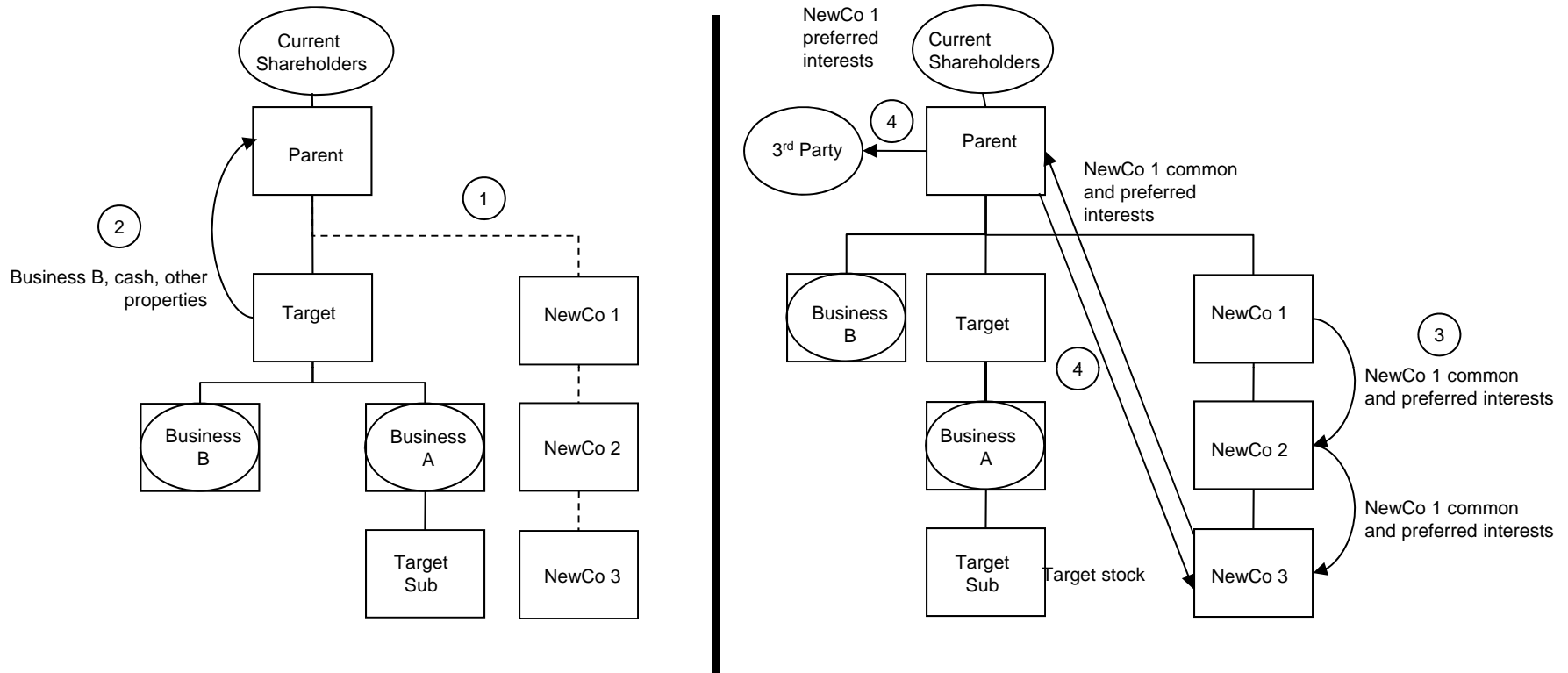

**Step 1:** Parent will form NewCo 1. NewCo 1 will form NewCo 2. NewCo 2 will form NewCo 3. The three entities will be formed as LLCs and will elect to be treated as corporations for federal income tax purposes.

**Step 2:** Target will distribute cash, Business B and various other properties to Parent. This distribution is intended to be part of the deemed section 332 liquidation in connection with the section 338(h)(10) election for Target.

**Step 3:** NewCo 1 will contribute its common membership interests and preferred membership interests to NewCo 2. NewCo 2 will contribute the NewCo 1 common and preferred membership interests to NewCo 3.

**Step 4:** Parent will transfer 100% of the stock of Target to NewCo 3 in exchange for NewCo 1 common and preferred membership interests. Pursuant to a binding obligation, Parent will transfer the NewCo preferred interests to an unrelated third party. A section 338(h)(10) election will be made with respect to the acquisition of the stock of Target.

# PLR 201126003

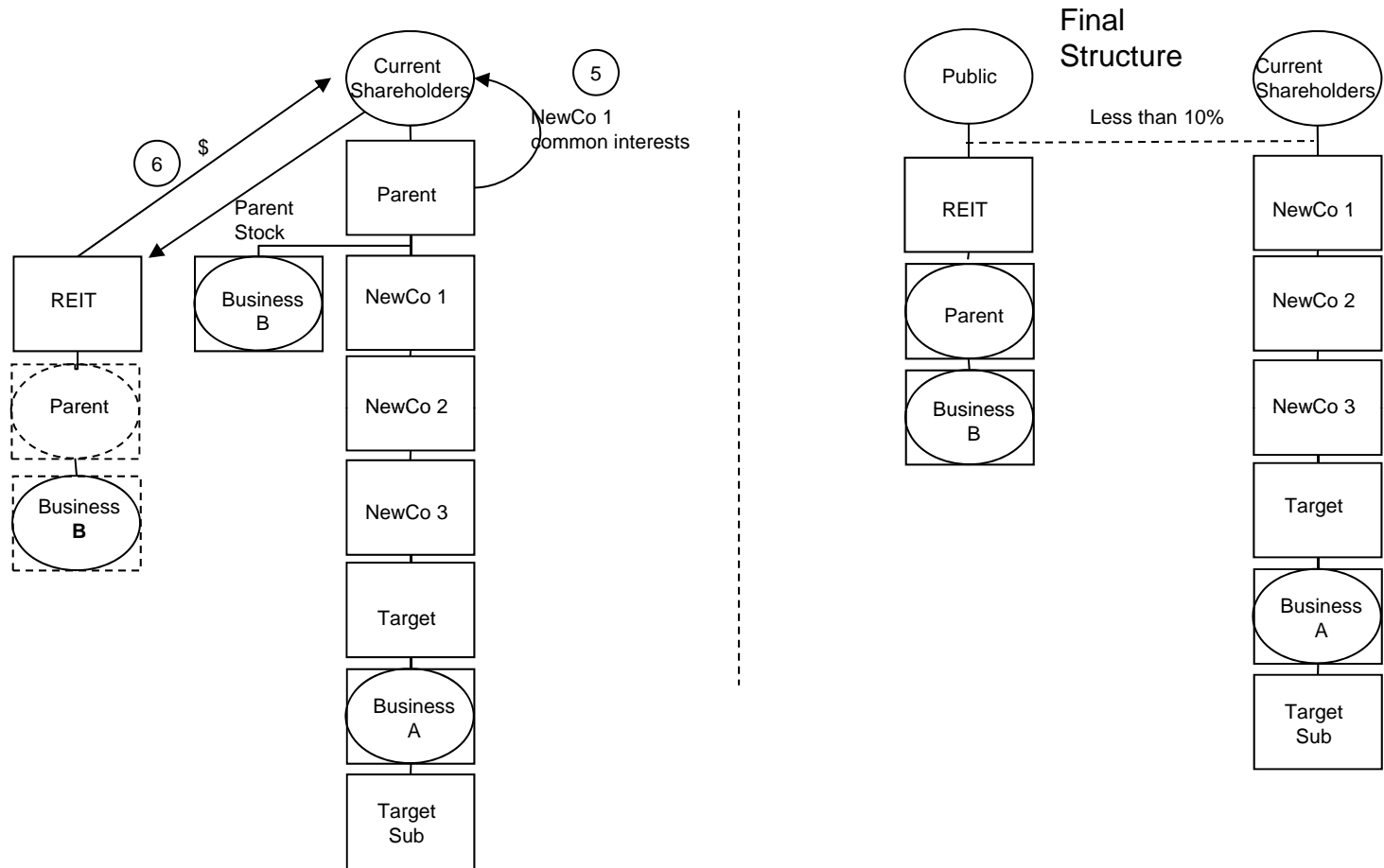

**Step 5:** Parent will distribute 100% of the NewCo 1 common membership interests to the Current Shareholders. The distribution is intended to constitute a dividend pursuant to sections 301 and 316.

**Step 6:** Current Shareholders will sell their parent stock to REIT and Parent and Business B will elect REIT status. Upon exercise of an option, REIT may acquire 9.9% of NewCo 1's common interests from NewCo 1.

# PLR 201145007

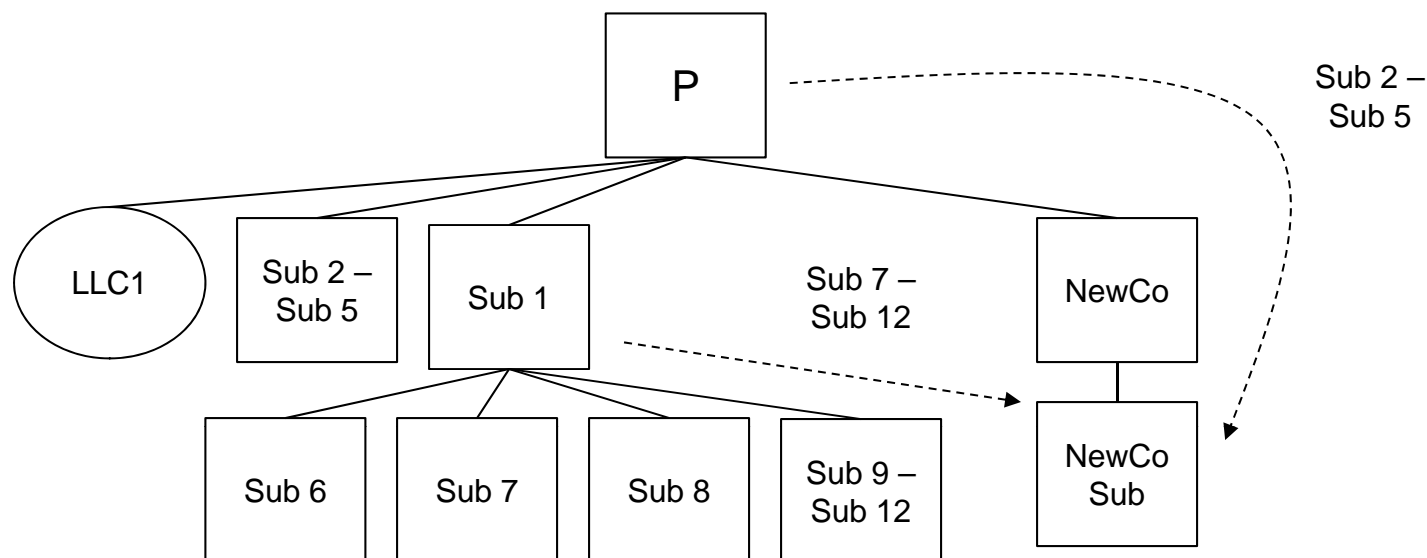

Facts: Parent was the parent of an affiliated group of corporations filing a life-nonlife consolidated return that conducted Business A and Business B. Parent owned all of the stock of Sub 1. Parent also owned (i) all of the interests in LLC1, a disregarded entity that conducted a part of Business A, and (ii) the stock of Subs 2 through 5. Sub 1 owned (i) all of the outstanding stock of Sub 6, which conducted the majority of Business A and a portion of Business B; (ii) Sub 7, which conducted a part of Business B and a part of Business A; (iii) Sub 8, which conducted a part of Business B; and (iv) the stock of Subs 9 through 12.

Parent formed Newco, which formed Newco Sub. NewCo issued NewCo common stock and NewCo preferred stock to NewCo Sub. All assets and liabilities relating to Business A were transferred and consolidated in S1, LLC1, and Sub 6, and all assets and liabilities relating to Business B were transferred and consolidated into the remaining applicable Subs.

To separate Business B from Business A, Parent transferred Subs 2 through 5 to Newco Sub, and Sub 1 transferred Subs 7 through 12 to Newco Sub. In exchange, Parent and Sub 1 each received a pro rata share of the NewCo common and preferred stock held by NewCo Sub. Parent and Sub 1 immediately sold the NewCo preferred stock to certain investors for cash pursuant to a preexisting agreement, which Parent used to repay certain indebtedness (Sub 1 distributed the cash and NewCo common stock it received to Parent).

# PLR 201145007

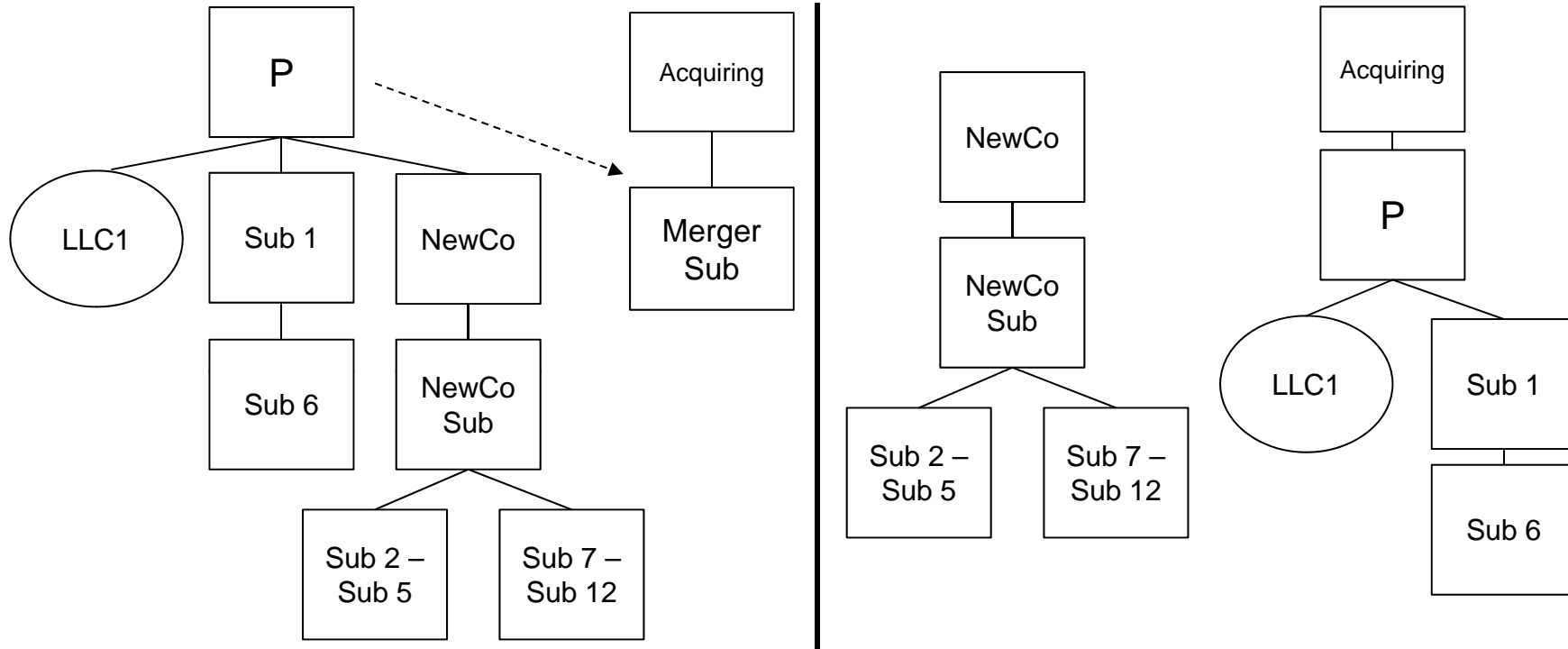

Facts (cont'd): Acquiring formed Merger Sub, which merged with Parent, with Parent surviving. Immediately after the Merger, Acquiring owned 100 percent of Parent, the investors held all of the Newco preferred stock, Parent's former common and preferred shareholders had received cash and held all of the Newco common stock, and neither Parent nor Sub 1 owned any stock in Newco.

The parties intended to make section 338(h)(10) elections with respect to the transfers of the subsidiary stock made by Parent and Sub 1 (Subs 2-5 and Subs 7-12, respectively) and with respect to the deemed transfers of stock of certain direct and indirect subsidiaries owned by such subsidiaries (Subs 13-39). Parent expected that the deemed asset sales resulting from the section 338(h)(10) elections with respect to the transferred subsidiaries would generate a net ordinary loss, life insurance company loss from operations, or both, and net capital gain.

# PLR 201145007

## Rulings:

- Newco Sub’s acquisitions of the stock of the subsidiaries transferred by Parent and Sub 1 qualify as “qualified stock purchases” under section 338(d)(3), and, assuming a section 338(h)(10) election is made with respect to its direct shareholder, the deemed sale of the stock of each of the lower-tiered subsidiaries (Subs 13-39) resulting from the deemed asset sale of the respective transferred subsidiary will qualify as a QSP.
- Parent (as the common parent of the selling consolidated group) and Newco Sub (by the common parent of its consolidated group) will be eligible to make section 338(h)(10) elections with respect to such QSPs.
- Parent’s group will be entitled to deduct in the taxable year ending on the closing date of the Merger, to the extent otherwise deductible, losses recognized by the subsidiaries transferred (directly and indirectly) by Parent and Sub 1 on the deemed sales of their assets.
- Neither Newco nor Newco Sub will be a successor to Parent for purposes of section 1504(a)(3), and Newco and its direct and indirect subsidiaries that are includible corporations and that satisfy the ownership requirements of section 1504(a)(2) will be members of an affiliated group of corporations entitled to file a consolidated federal income tax return immediately following the Merger.

## Participation by T Management -- Section 351

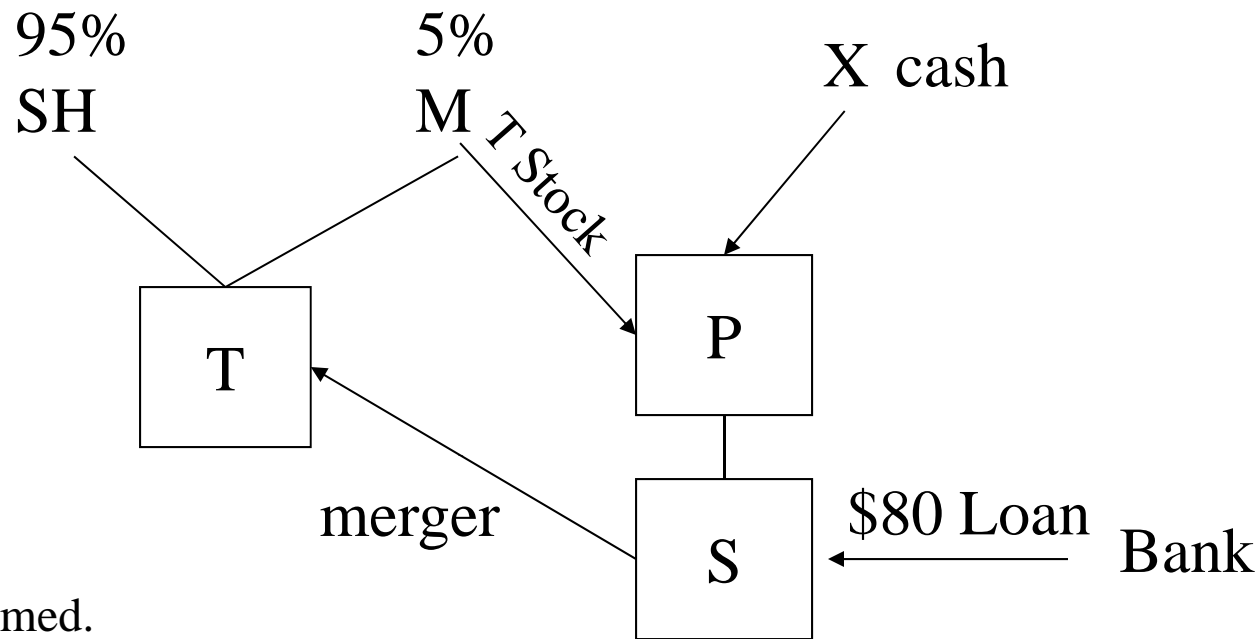

1. P is formed.
2. Management contributes 5% of T stock and X contributes \$15 in cash, in exchange for 25% and 75% interest in P, respectively.
3. P forms S.
4. \$80 is borrowed, secured by the T assets, to acquire the T stock.
5. S is merged into T with T surviving.
6. Acquisition of T stock with borrowed funds constitutes a redemption.
7. T stock from management -- section 351 -- is not purchased.
8. Section 338 will not apply unless X contributes cash equal to four times the value of management's stock and that cash is used to purchase T stock.

## Sale by T Management to P -- Newly Formed P

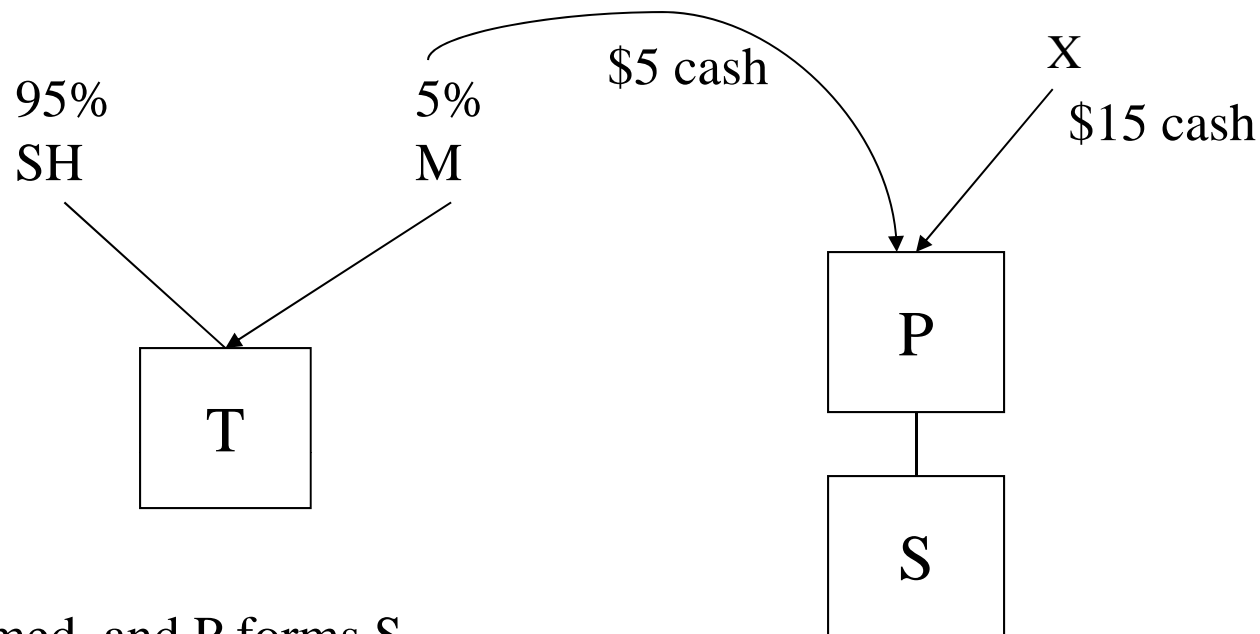

1. P is formed, and P forms S.
2. Management (M) contributes \$5 in cash and X contributes \$15 cash to P.
3. \$80 is borrowed, secured by the T assets, to acquire the T stock.
4. S is merged into T with T surviving. M receives \$5 in the transaction.

IRS might ignore the \$5 contribution by M and treat the transaction as if M transferred its T stock to P in a section 351 exchange. Alternatively, IRS could treat the transaction as if M contributed its T stock and \$5 cash to P in exchange for P stock and \$5 in cash (boot).

The result is the same as the prior example – section 338 is not available.



## Section 338(h)(10) and “Busted 351” Transaction

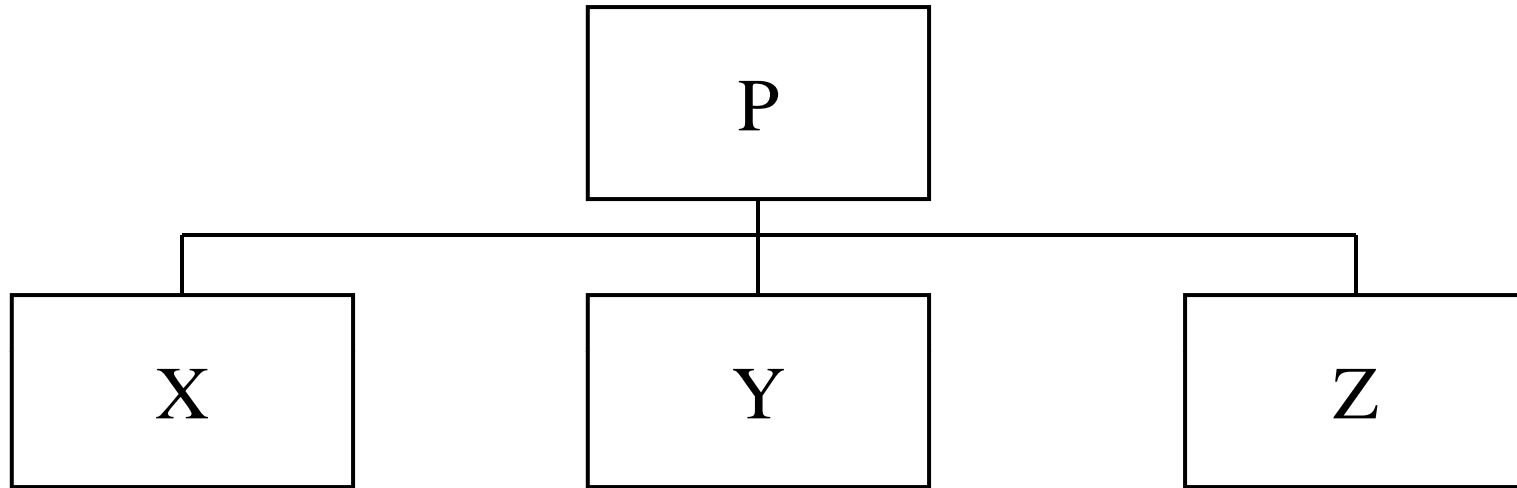

### Facts

1. P, X, Y, and Z file a consolidated return.
2. P wishes to sell X and Y to the public and to step up the basis of the X and Y assets.

## Section 338(h)(10) and “Busted 351” Transaction Continued

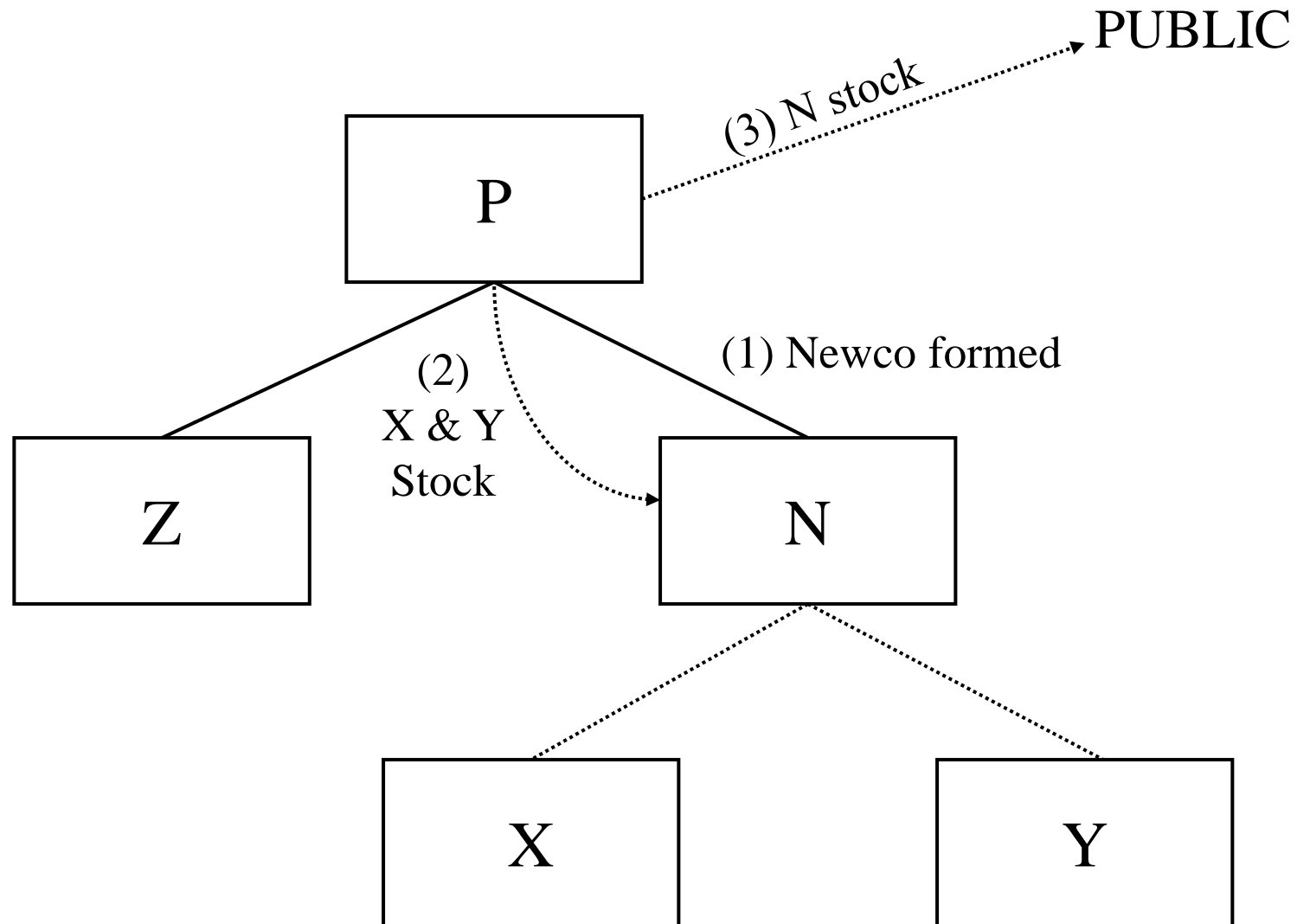

3. P forms Newco (N) and P transfers the X and Y stock to N.  
Pursuant to a prearranged plan, P sells the N stock to the Public.

# Section 338(h)(10) and “Busted 351” Transaction Continued

## Results

1. The transfer of the X and Y stock to N should not qualify as a section 351 transaction. P is not in control of N immediately after the transfer. See Rev. Rul. 79-194, 1979-1 C.B. 145; TAM 9747001 (July 1, 1997); PLR 9541039 (July 20, 1995), as modified by PLR 9549036 (Sept. 12, 1995); PLR 9142013 (July 17, 1991).
2. Thus, N is deemed to purchase the X and Y stock.
3. In this event, P and N can file a section 338(h)(10) election to treat the transaction as a sale of assets by X and Y followed by section 332 liquidations.
4. The regulations contain a similar example. See Treas. Reg. § 1.338-3(b)(3)(iv), Ex. 1.
5. How much stock does P have to sell?
  - P must sell more than 20% of N stock for section 351 not to apply. See section 351(a) and 368(c).
  - P must sell at least 50% of the N stock so that P and N are not related for purposes of section 338(h)(3)(A)(iii).
  - P must sell more than 80% of the N stock to avoid the application of the anti-churning rules of section 197(f)(9).
  - Prior to the effective date of Treas. Reg. § 1.197-2 it was possible that the anti-churning rules could have applied even if P sold all of the N stock because of the momentary relationship between P and N. See Old Prop. Treas. Reg. § 1.197-2(h)(6)(ii).

## Section 338(h)(10) and “Busted 351” Transaction Variation

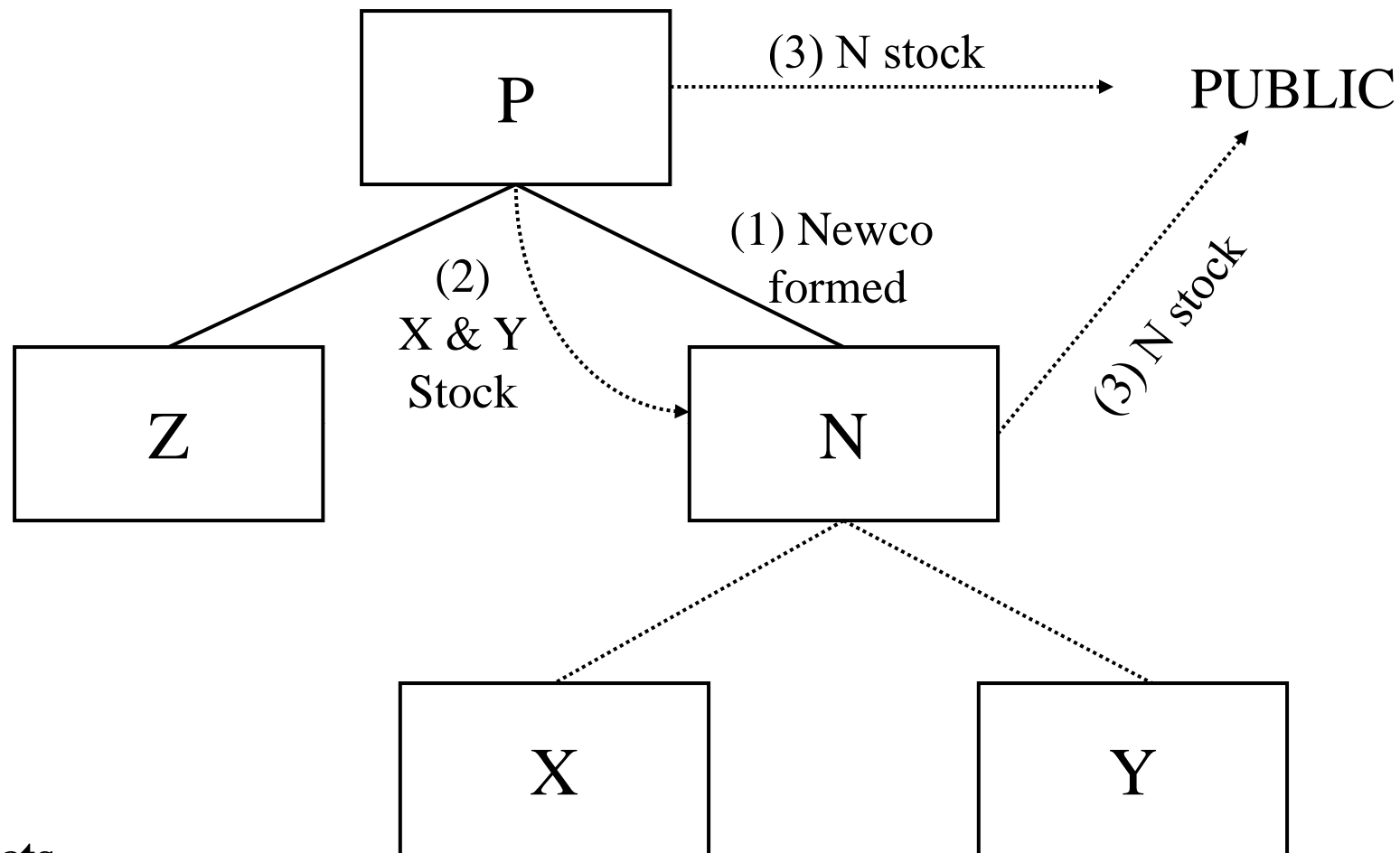

### Facts

1. Same as above, except that both P and N sell stock to the public.

### Results

1. Does section 351 apply? If so, section 338(h)(10) is not available.
2. Does the answer change if P and N each use different investment bankers?

## PLR 200427011

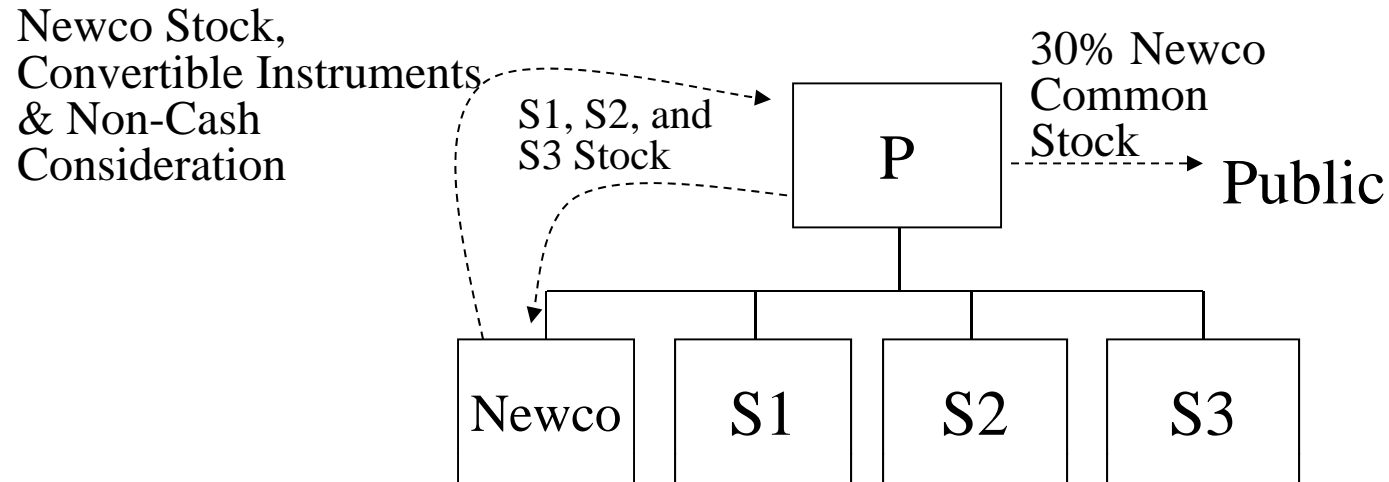

P forms Newco with a minimal amount of capital. P executes a “firm commitment” underwriting agreement to sell Newco stock and convertible instruments in an IPO. P then contributes the shares of subsidiaries S1, S2, and S3 to Newco in exchange for all the Newco common stock, Newco convertible instruments, and non-stock consideration (*e.g.*, short-term promissory notes or cash). Pursuant to the underwriting agreement, P sells 30% of the common stock to the public. P also represents that, although not legally obligated to do so, it intends to reduce its interest in Newco below 50% within two years of completing the sale of the 30% of the common stock to the public.

Can P and Newco make a section 338(h)(10) election with respect to the contributed subsidiaries? See P.L.R. 200427011 (October 6, 2003); *Merrill Lynch & Co., Inc. v. Commissioner*.

## Section 338(h)(10) Stock Sale and Spin-off—Facts

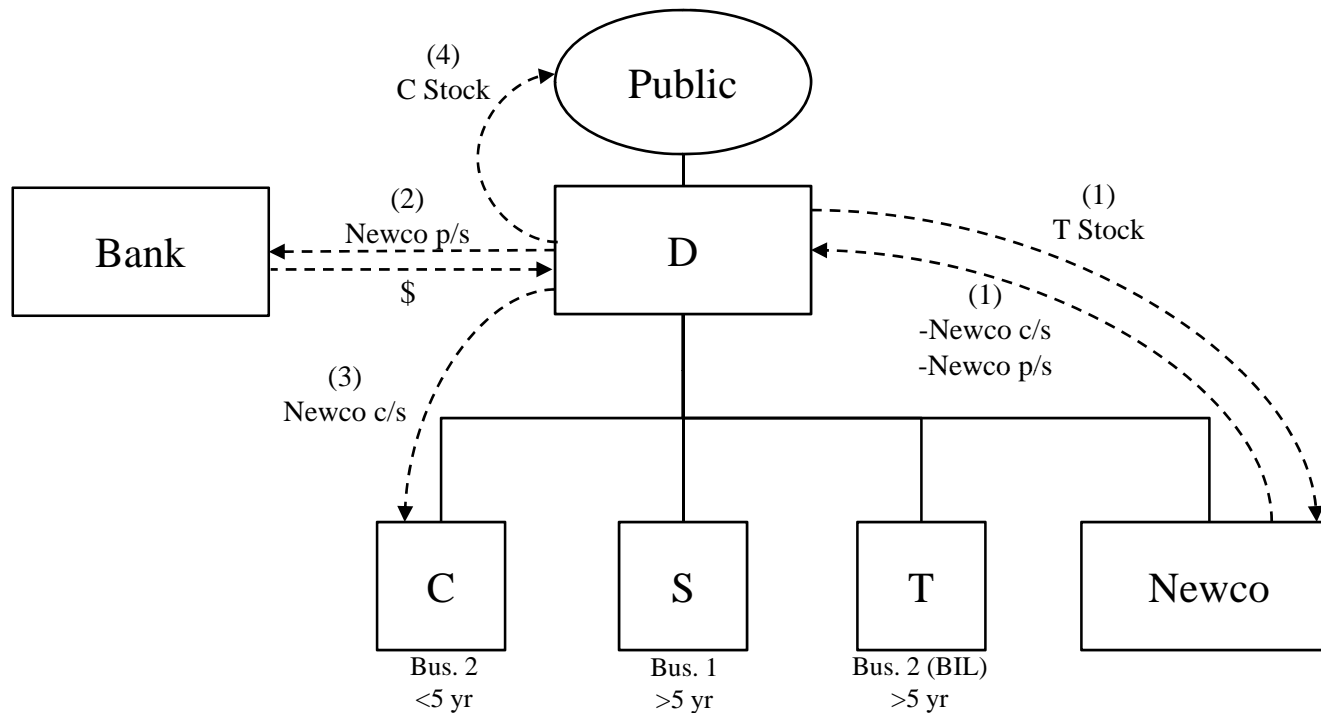

- Publicly-traded D owns all the stock of S (Bus. 1 >5 years), T (Bus. 2 >5 years) and C (Bus. 2 <5 years)
- T's assets have built-in loss
- In a plan to separate Business 2 from Business 1, D takes the following steps:
  1. D forms Newco and transfers the T stock to Newco in exchange for all the Newco stock: common stock and nonvoting vanilla section 1504(a) preferred stock; D and Newco file a section 338(h)(10) election
  2. T sells the Newco preferred stock to unrelated Bank
  3. D transfers the Newco common stock to C for no consideration
  4. D distributes all the C stock to its shareholders, *pro rata*

# Section 338(h)(10) Stock Sale and Spin-off—Analysis

## After Steps 1-4:

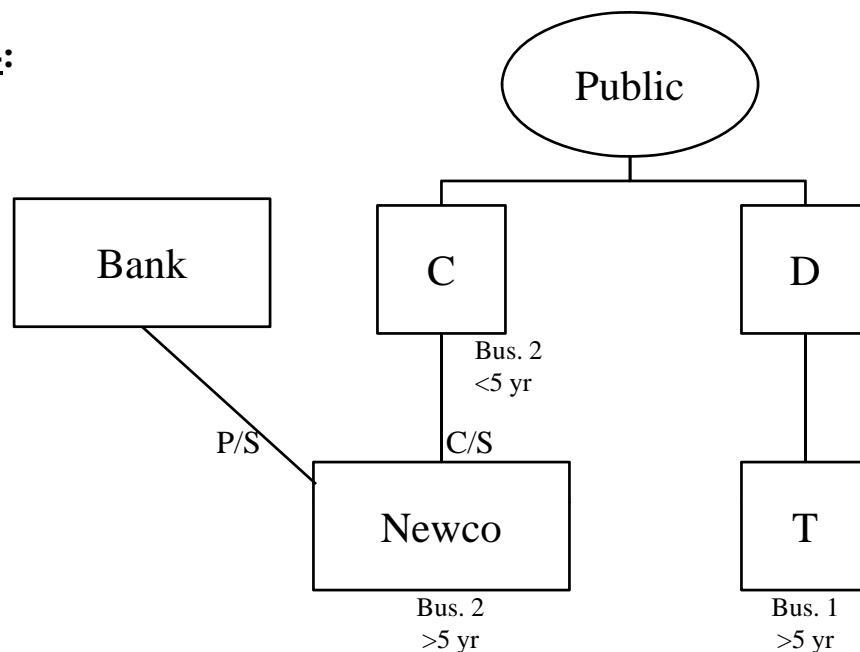

- D’s transfer of the T stock to Newco (Step 1) is a “qualified stock purchase,” eligible for a section 338(h)(10) election. Section 338(d)(3), (h)(3) (*See* PLRs 201203004, 200520003)
  - Taxable “busted” section 351 exchange because of the sale of the Newco preferred stock (Step 2). Section 338(h)(3)(A)(i), (ii)
  - No attribution of ownership (section 318(a)) of T stock from D to Newco (section 338(h)(3)(A)(iii)), because relatedness is determined immediately after the spin-off of C. Treas. Reg. § 1.338-3(b)(3)
  - T recognizes built-in loss on deemed asset sale to New T. Treas. Reg. §§ 1.338(h)(10)-1(d)(2)-(4)
  - T’s loss is taken into account immediately before spin-off of C. Treas. Reg. §§ 1.267(f)-1(a)(2), 1.1502-13(d)
- Spin-off of C (Step 4) qualifies under section 355
  - D “controls” C (section 368(c)); it does not matter that C does not “control” Newco
  - S’s Business 1 qualifies as D’s active trade or business (“ATB”), because S is a member of D’s separate affiliated group (“SAG”). Section 355(b)(3); Prop. Treas. Reg. § 1.355-3(b)(1)(ii)
  - New T’s Business 2 qualifies as C’s ATB. Section 355(b)(3); Notice 2007-60
    - Before step 3, T and New T are both members of D’s SAG
    - After step 3, New T is a member of C’s SAG

# Section 338 Election Rules

## Chain of Corporations

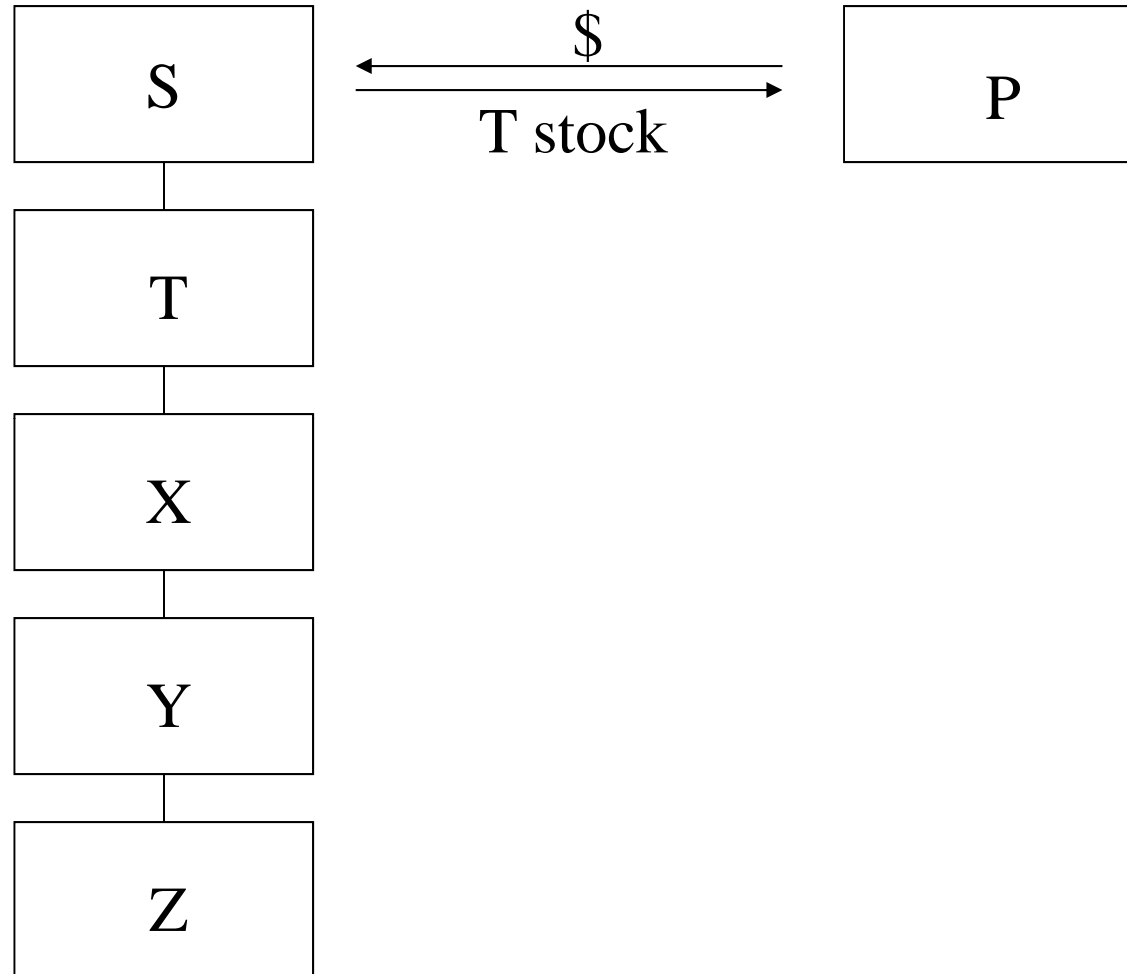

1. P purchases the stock of T from S and makes a section 338 election for T.
2. May P make a section 338 election for X, Y and Z?
3. May P make a section 338(h)(10) election for X, Y and Z?



# Insolvency

# Application of Section 338 to the Purchase of an Insolvent Corporation -- Insolvent Target Corporation

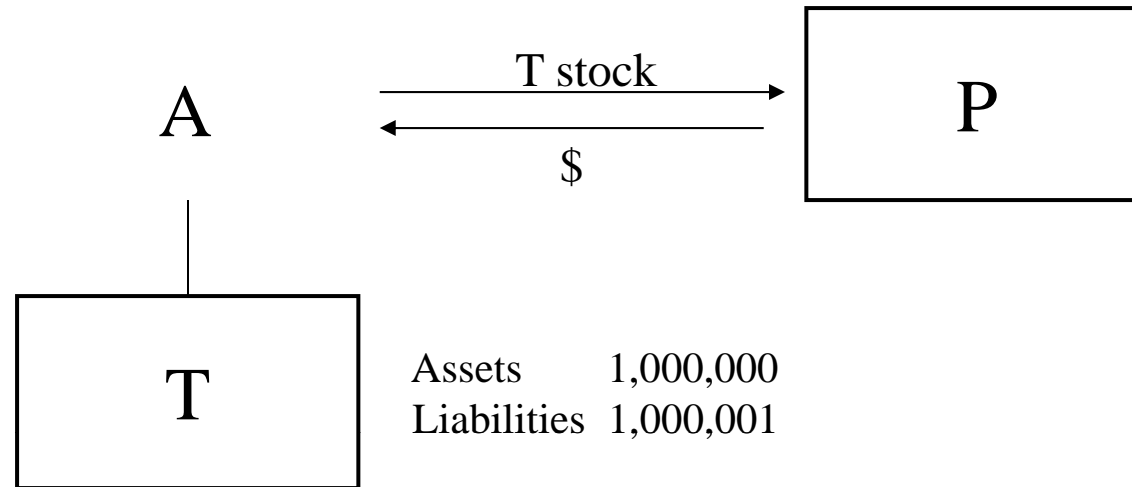

Corporation T owns assets with a value of \$1,000,000 and has liabilities of \$1,000,001.

P purchases all the stock of T from individual A for \$1 and attempts to make a section 338(g) or section 338(h)(10) election with respect to T.

What are the results of this election?

## **References**

Section 338(h)(3)(A)

Treas. Reg. §§ 1.332-2(b), 1.338-3(b)(2)

Rev. Rul. 56-387, 1956-2 C.B. 189

# Application of Section 338(h)(10) to the Purchase of an Insolvent Corporation -- Insolvent Target Subsidiary

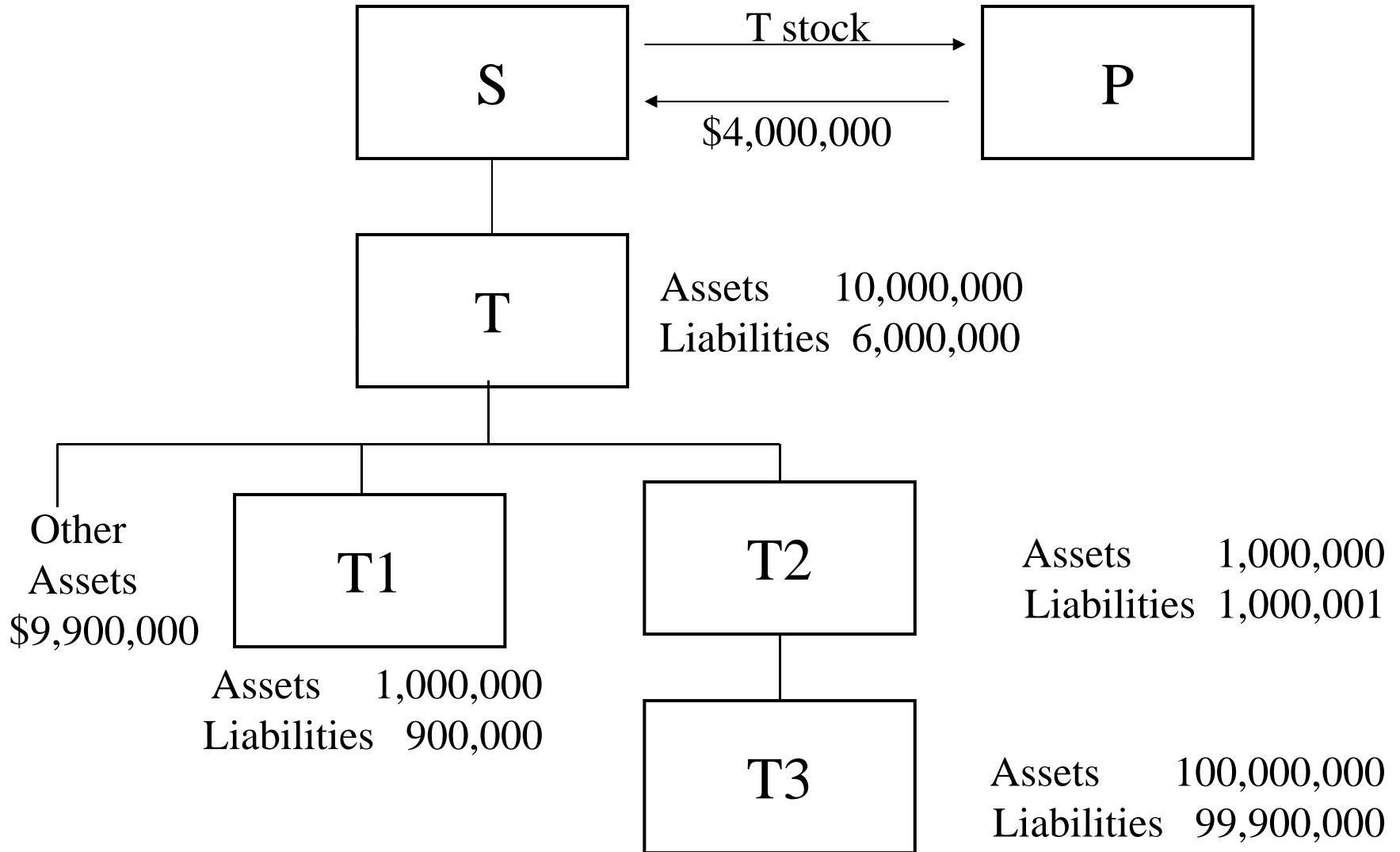

# Liquidating a Subsidiary With Preferred Stock

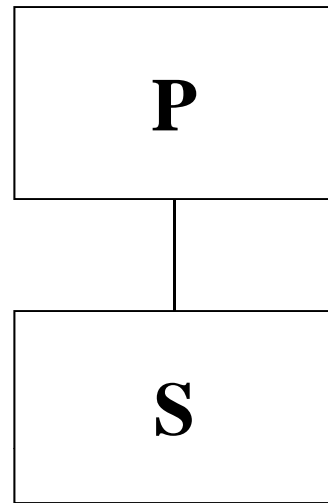

**Year 1**  
**Preferred Stock \$400**  
**Equity \$100**

**Year 2 (End of Year)**  
**S adopts plan of liquidation**

**S Assets \$ 50**

## **Facts:**

**Year 1** - P capitalized S with \$100 of equity and \$400 of preferred stock.

**Year 2** - S incurred operating losses of \$450.

**End of Year 2** - S adopts a plan of liquidation, distributing its only assets (fmv = \$50) to P in satisfaction of its preferred stock liquidation preference to P.

Does the analysis change if in Year 1 P capitalized S with \$100 of equity, \$260 of preferred stock and \$40 of debt?

## **Authorities**

Sections 165(g), 331, 332(b)(2), 336(b), 346

Treas. Reg. § 1.332-2(b) and 1.368-2(d)(4); Prop. Treas. Reg. § 1.332-2(b) and 1.332-2(e), Example 2

*Spaulding Bakeries*, 27 T.C. 684 (1957), *aff'd*, 252 F.2d 693 (2d Cir. 1958), *nonacq.* 1957-2 C.B. 8

*H.K. Porter & Co. v. Commissioner*, 87 T.C. 689 (1986)

Rev. Rul. 2003-125; Rev. Rul. 70-489; Rev. Rul. 68-602; Rev. Rul. 59-296

## Section 338(h)(10) – Spaulding Bakeries Example

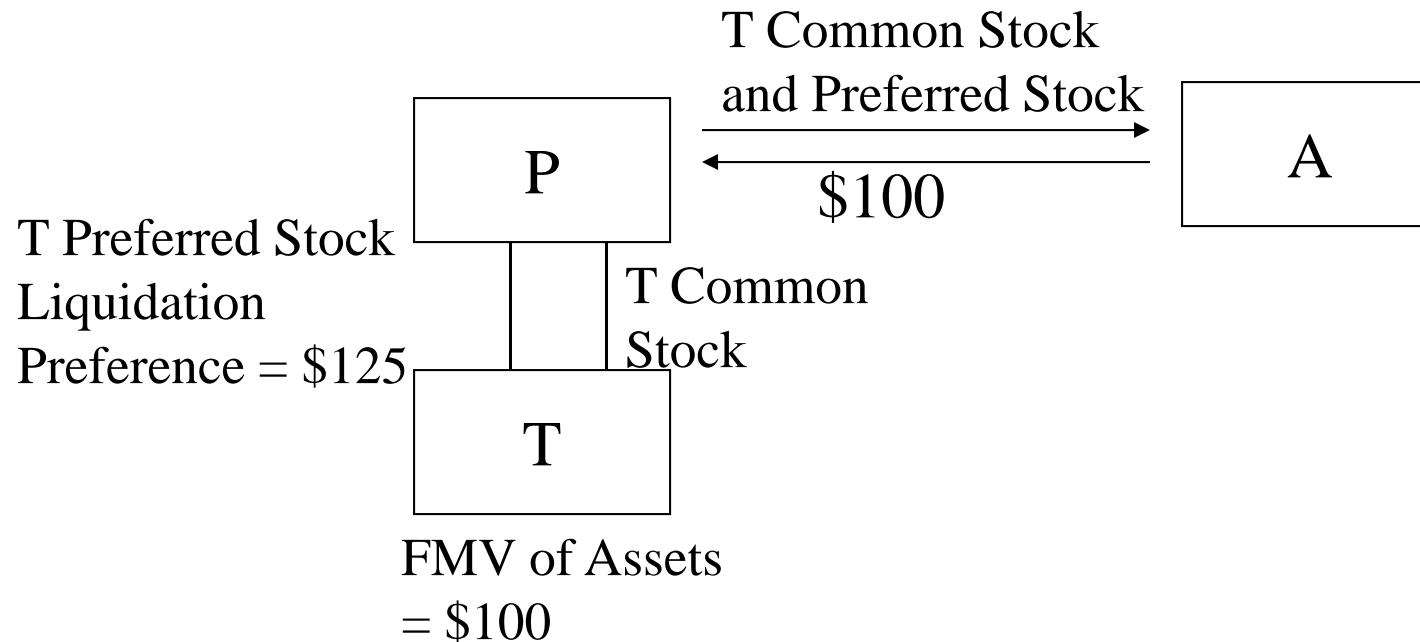

P owns all the outstanding common and preferred stock of T. The preferred stock has a liquidation preference of \$125. At a time when T's assets are worth \$100, A acquires all the outstanding common and preferred stock of T from P for \$100. A and P join in a section 338(h)(10) election, what results?

## Rev. Rul. 68-602

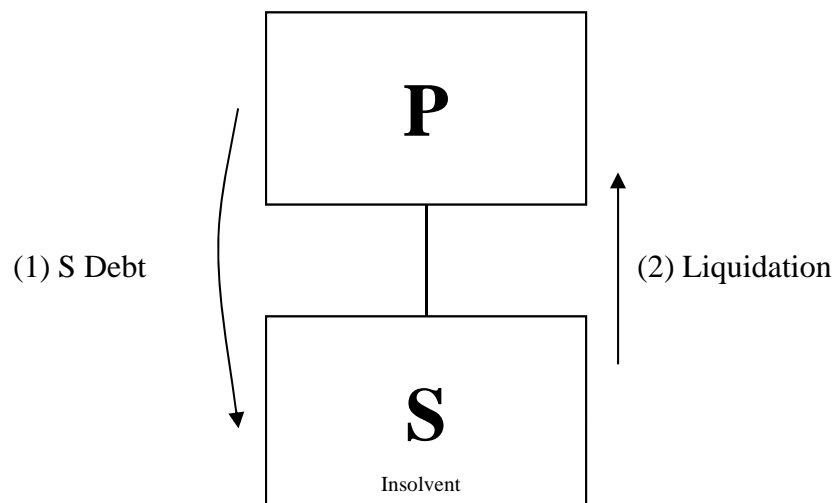

In Rev. Rul. 68-602, P owned all the stock of S. S was indebted to P in an amount greater than the fair market value of its assets. P cancelled the debt owed to it by S and immediately thereafter S transferred all of its assets subject to its liabilities to P pursuant to a plan of liquidation. Since the cancellation of debt was an integral part of the liquidation and had no independent significance, the Service disregarded the cancellation.

## Rev. Rul. 78-330

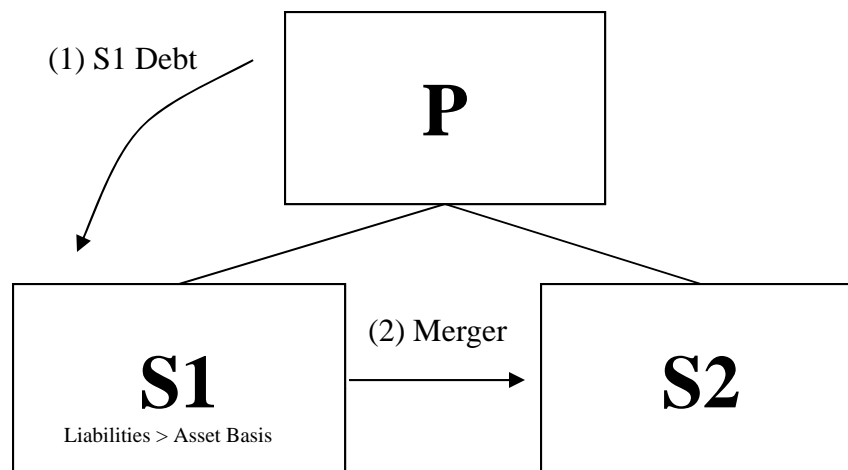

In Rev. Rul. 78-330, P owned all the stock of S1 and S2. P gratuitously cancelled the debt owed by S-1 to P so that the basis of S-1's assets would exceed its liabilities. S-1 merged with and into S2. Since P's cancellation of S-1's debt had independent economic significance because it resulted in a genuine alteration of a previous bona fide business relationship, the cancellation was respected.

# Insolvent Subsidiary Liquidation Capitalization of Subsidiary Debt – Other Third Party Debt

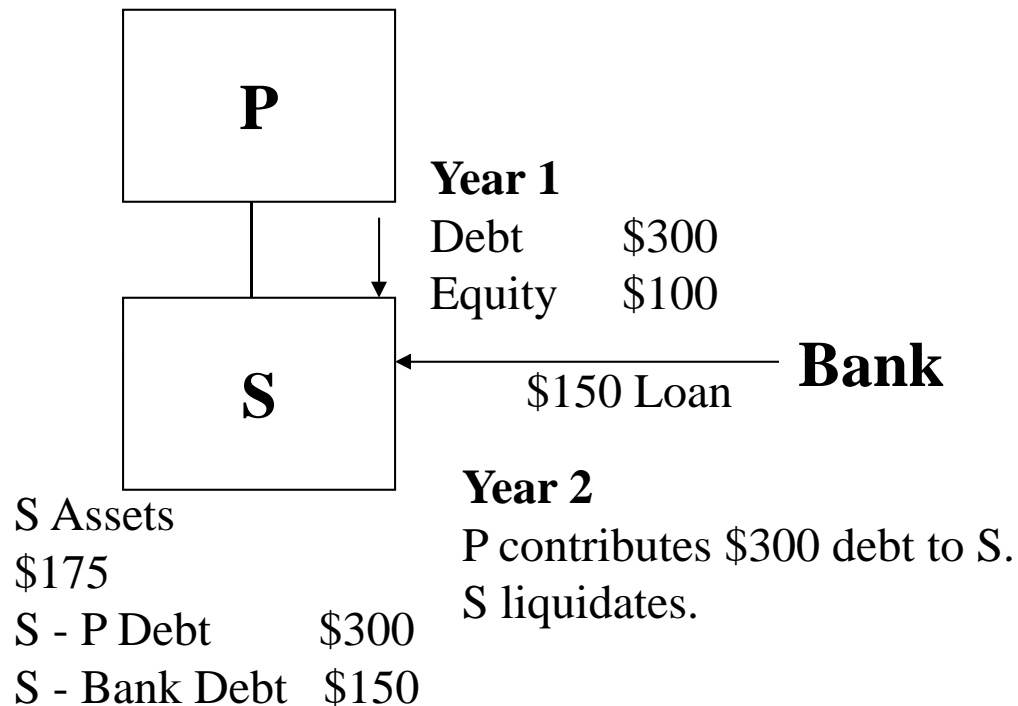

**Facts:**

**Year 1** - P capitalized S with \$100 of equity and \$300 of debt. S borrows \$150 from Bank.

**Year 2** - S incurred operating losses of \$375.

**End of Year 2** – At a time when S is otherwise insolvent, P contributes its \$300 debt to equity causing S to become solvent. S adopts a plan of liquidation repaying the bank debt in full and distributing its remaining assets (\$25) to P. Absent the contribution bank and P would have shared 2/3 to 1/3 in S assets of \$175 upon liquidation.

## CCA 200818005 (Jan. 29, 2008)

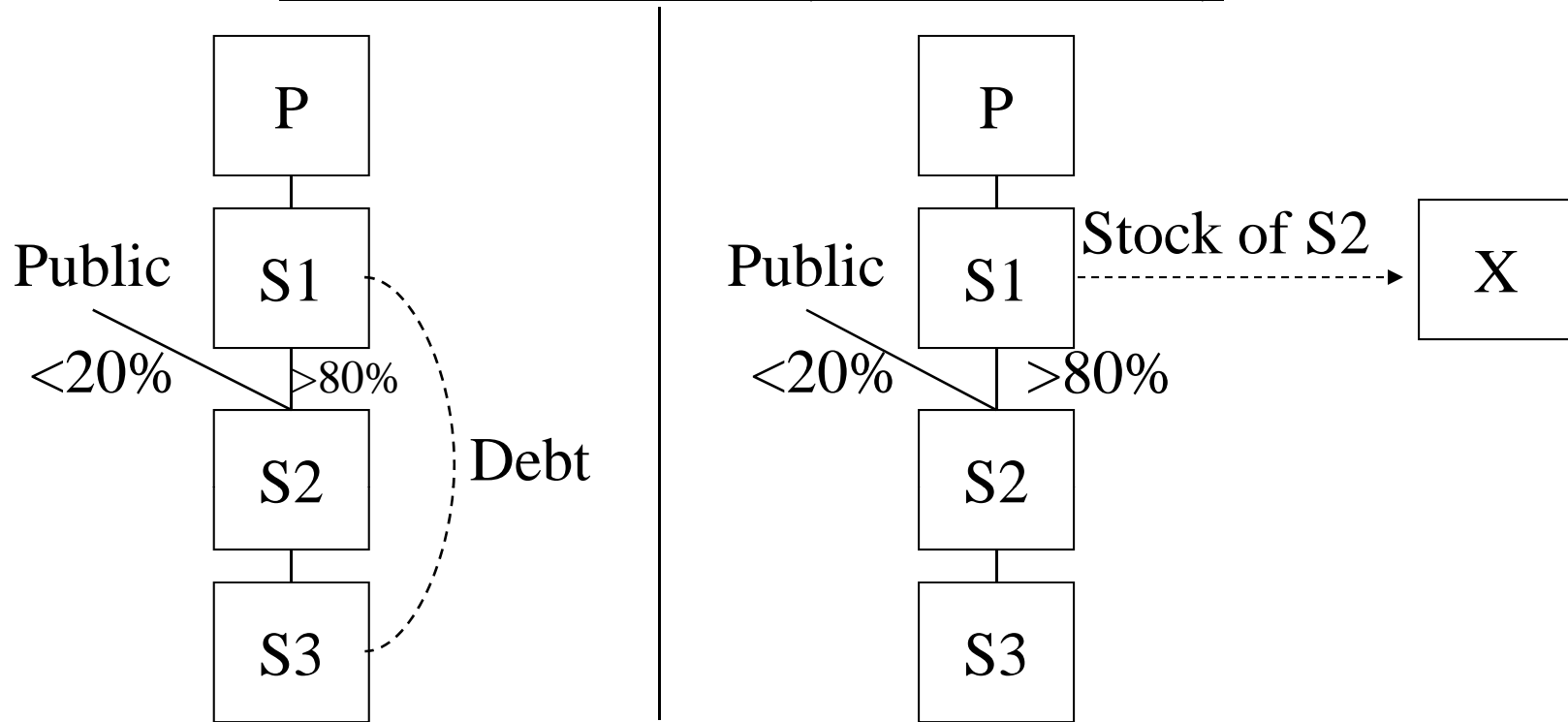

- P is the common parent of a consolidated group. P owns all of the stock of S1. S1 owns x% (at least 80%) of the stock of S2. The public owns the remaining shares of S2. S2 owns all the stock of S3. S1 was the lender on an intercompany indebtedness with S3. Prior to the transaction, S3's liabilities exceed the fair market value of its assets and S2's liabilities exceed the fair market value of its assets.
- On Date 1, as a condition to a pending sale, S1 forgave a portion of the indebtedness it had with S3. Immediately after this cancellation, the net value of S3's assets exceeded its liabilities and the net value of S2's assets (including the stock of S3) exceed S2's liabilities. On Date 2, S1 sold all of its stock in S2 to purchaser X, an unrelated third party. On Date 3, P and X make a section 338(h)(10) election with respect to the sale of the stock of S2 and the deemed sale of the stock of S3.
- The National Office determined that the deemed liquidation of S2 pursuant to the section 338(h)(10) election would not qualify under section 332. The National Office determined that the cancellation of the indebtedness between S1 and S3 would be disregarded as in Rev. Rul. 68-602. Because the cancellation of indebtedness would be disregarded, S1 would not be treated as receiving any net value for its stock interest in S2 and therefore the liquidation would not qualify under section 332. The CCA stated that the fact that there may be economics significance in the cancellation of indebtedness does not alter the result. The CCA distinguished Rev. Rul. 78-330 because there was no liquidation in the transaction at issue in that ruling.



# Rev. Rul. 2003-125

## Situation 1

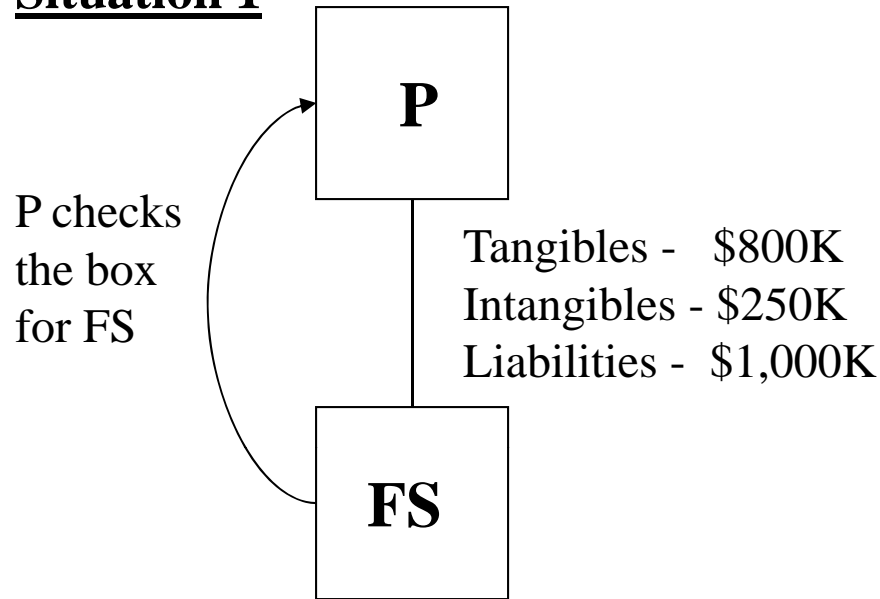

## Situation 2

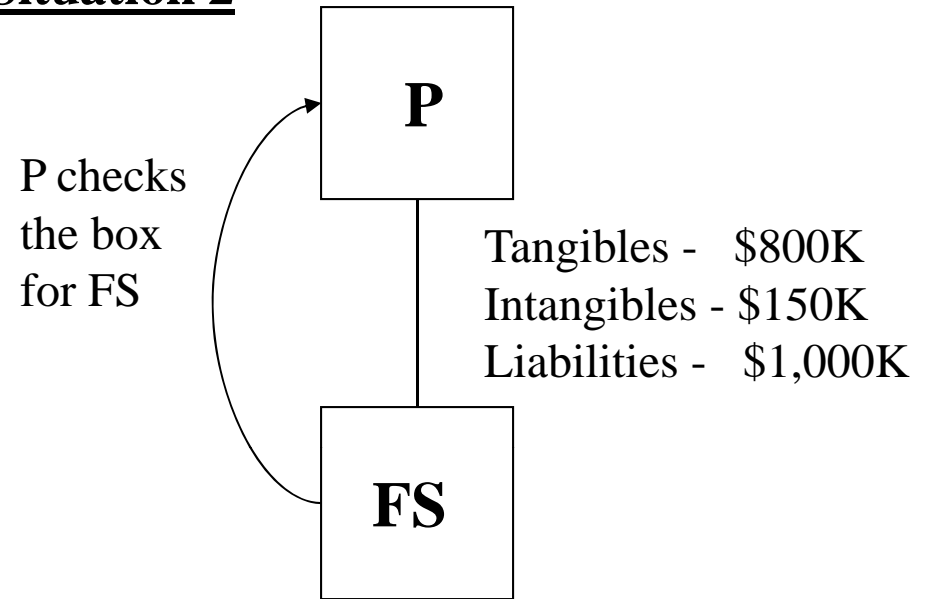

**Situation 1:** Corporation P owns 100 percent of the stock of Subsidiary FS, an entity organized under the laws of Country X that operates a manufacturing business. FS is an “eligible entity” under Treas. Reg. § 301.7701-3(a) and, prior to July 1, 2003, FS is treated as a corporation for federal tax purposes (under section 7701(a)(3)). On December 31, 2002, the stock of FS was not worthless. On July 1, 2003, P files a check-the-box election for FS, changing the classification of FS from a corporation to a disregarded entity for federal tax purposes effective as of that date. At the close of the day immediately before the effective date of the election, the fair market value of FS's assets, including intangible assets such as goodwill and going concern value, exceeds the sum of its liabilities. However, at that time, the fair market value of FS's assets, excluding intangible assets such as goodwill and going concern value, does not exceed the sum of its liabilities. After the change in entity classification election is effective, FS continues its manufacturing operations.

**Situation 2:** Same facts as in Situation, except that at the close of the day immediately before the effective date of the election, the fair market value of FS's assets, including intangible assets such as goodwill and going concern value, does not exceed the sum of its liabilities.

## Rev. Rul. 2003-125 (Cont.)

### **Rev. Rul. 2003-125 clarifies that:**

- Where a worthless stock deduction is claimed upon the liquidation of a corporation and the stock did not become worthless in a prior tax year, the standard for determining worthlessness is whether the shareholders receive payment for their stock. See H.K. Porter Co. v. Commissioner, 87 T.C. 689 (1986).
- A shareholder receives no payment for its stock in a liquidation if, at the time of the liquidation, the fair market value of the corporation's assets is less than the corporation's liabilities.
- The value of intangible assets, including goodwill and going concern, is included in determining the fair market value of the entity's assets immediately before the deemed liquidation.
- Certain facts, such as (i) the continuation of the corporation's business after a liquidation without a substantial infusion of capital, and (ii) the revenues of that business following the liquidation exceed the amount required to service debt that existed immediately prior to the liquidation, may suggest that at the time of liquidation the fair market value of the liquidating entity's assets, including goodwill and going concern value, exceeded the sum of its liabilities.

# GLAM 2011-003

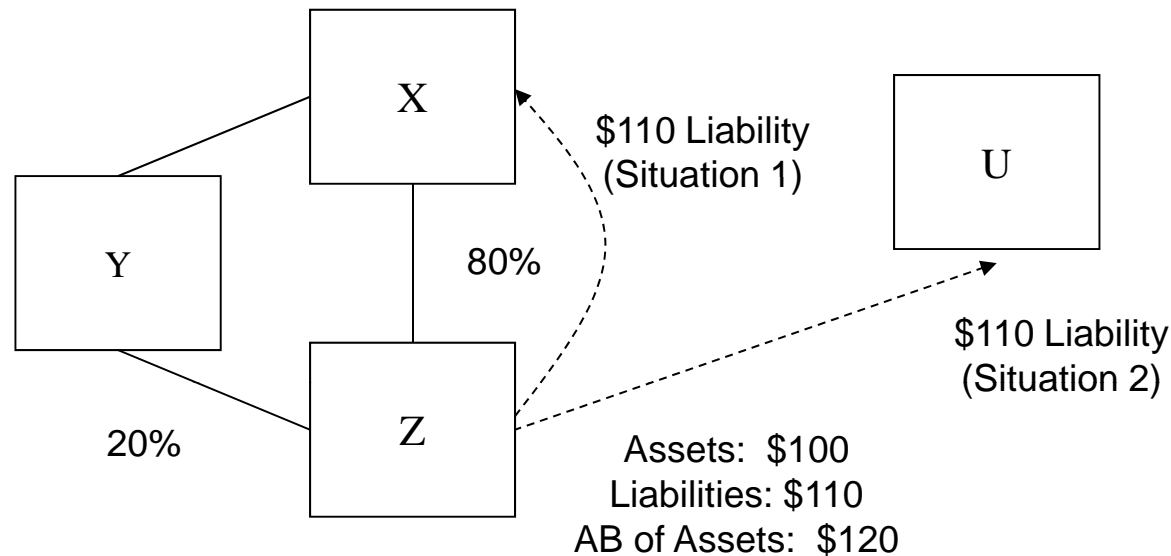

Situation 1: X, a U.S. Corporation, owns 100 percent of Y, a foreign corporation. X also owns 80 percent of Z, a foreign corporation. Y owns the remaining 20 percent interest in Z. X's ownership of Z satisfies the 80 percent vote and value test of section 1504(a)(2).

The fair market value of Z's assets is \$100, and Z has an adjusted basis in its assets of \$120. Z has \$110 of liabilities, all of which are owed to X. The liabilities are not securities within the meaning of section 165(g)(2), and, at the time they were incurred, constituted genuine indebtedness that Z expected to repay in full. X's adjusted basis in its Z stock is \$100, and Y's adjusted basis in its Z stock is \$30.

Z is an eligible entity for purposes of the entity classification rules of Treas. Reg. § 301.7701-3. Z properly elects to change its classification from a corporation to a partnership under Treas. Reg. § 301.7701-3(c)(1)(i).

Situation 2: The facts are the same as in Situation 1, except that all of Z's liabilities are owed to U, an unrelated foreign corporation.

# GLAM 2011-003

Issue 1 – Is a shareholder of an insolvent corporation that elects to be treated as a partnership allowed a worthless security deduction under section 165(g)?

- Under Treas. Reg. § 301.7701-3(g)(1)(ii), Z is deemed to distribute its assets and liabilities to X and Y in liquidation of Z.
  - Because the FMV of Z's assets (\$100) is less than its liabilities (\$110), Z's shareholders do not receive payment for their stock.
  - Under section 165(g), in Situations 1 and 2, X and Y are entitled to worthless security deductions of \$100 and \$30, respectively (their basis in the Z stock), assuming they satisfy the other requirements under section 165(g).
- The GLAM cited Rev. Rul. 2003-125, which reached the same conclusion in the context of an insolvent foreign corporation that elected to be treated as a disregarded entity.

# GLAM 2011-003

Issue 2 – How are liabilities treated for federal tax purposes in transactions that are deemed to occur under Treas. Reg. § 301.7701-3(g)(1)(ii)?

- The distribution of Z’s liabilities followed by the contribution of the liabilities to the new partnership is not a significant modification of the liabilities for section 1001 purposes.
  - In Situations 1 and 2, the partnership acquires substantially all of Z’s assets and liabilities – Z is deemed to distribute its assets and liabilities to X and Y, who contribute them to the partnership.
  - The change in entity classification from a corporation to a partnership is not likely to result in a change in payment expectations.
  - No significant alteration occurs as a result of the deemed liquidation in Situations 1 and 2 – the election by Z does not affect the liabilities of Z with respect to its creditors under local law.
- The tax consequences of Z’s debt with respect to its partnership election are the same as if Z actually liquidates, shareholders of Z immediately form a new partnership, and Z’s debt survives the liquidation and becomes an obligation of the partnership.
- The liabilities are not treated under section 1001 as exchanged for new debt of the partnership as a result of Z’s election.

Issue 3 – Is a creditor of the insolvent corporation entitled to a bad debt deduction under section 166?

- Because the liabilities are treated as surviving Z’s deemed liquidation and as being contributed to the newly formed partnership, Z’s creditors in Situations 1 (X) and 2 (U) are not entitled to a bad debt deduction under section 166.
- Cf. Rev. Rul. 2003-125, which indicated that the foreign subsidiary’s creditors, including its parent corporation, may be entitled to a section 166 bad debt deduction.

# GLAM 2011-003

Issues 4 and 5 – What is the newly-formed partnership’s basis in the assets deemed contributed to it, and what is the basis of each partner’s interest in the new partnership?

- Z is deemed to distribute its assets and liabilities to X and Y in liquidation. Because Z is insolvent, sections 331 or 332 are inapplicable, and the basis of the assets is determined under section 1012 (i.e., the cost of the assets).
  - In Situations 1 and 2, because X is deemed to assume liabilities of \$88 in the deemed liquidation of Z (80% of \$110), X is deemed to receive assets with a basis of \$88, and because Y is deemed to assume liabilities of \$22 (20% of \$110), Y is deemed to receive assets with a basis of \$22.
- In Situations 1 and 2, X and Y are treated as contributing assets and liabilities, pro rata, to the newly formed partnership.
  - Under section 752(c), the amount of the liabilities treated as assumed by the partnership is limited to the FMV of the assets at the time of the deemed contribution (\$100).
    - Accordingly, X is deemed to contribute assets with a basis to X of \$88 and liabilities of \$80, and Y is deemed to contribute assets with a basis to Y of \$22 and liabilities of \$20.
  - Under section 721, no gain or loss is recognized to the partnership or X and Y on the deemed contribution.
  - Under section 723, the partnership's basis in the assets deemed contributed is \$110 (the AB of the assets to X and Y).
  - Cf. Prop. Treas. Reg. § 1.351-1(a)(1)(iii)(A) and (B), which would require a surrender and receipt of net value, respectively, in a section 351 transaction.
    - The GLAM takes the position that section 721 applies regardless of whether net value is transferred, contrary to the principles in the proposed no net value regulations.
    - See Preamble to Proposed No Net Value Regulations (“The IRS and the Treasury Department recognize that the principles in the proposed rules under section 351 may be applied by analogy to other Code sections that are somewhat parallel in scope and effect, such as section 721 . . .”).

# GLAM 2011-003

## Issues 4 and 5 (cont'd)

- In Situation 1, X's basis in its partnership interest is \$108 and Y's basis in its partnership interest is \$2.
  - The partnership is deemed to assume \$100 of the liabilities contributed by X and Y (\$80 and \$20, respectively), but because X bears the economic risk of loss for the liability, X's share of the liability is increased by \$100.
  - X's basis in its partnership interest is \$108 (adjusted basis in assets deemed contributed (\$88) under section 722 increased by the deemed contribution of money (\$20) under section 752(a)), and Y's basis in its partnership interest is \$2 (adjusted basis in assets deemed contributed (\$22) under section 722 decreased by a deemed distribution of \$20 under section 752(b)).
- In Situation 2, X's basis in its partnership interest is \$88 and Y's basis in its partnership interest is \$22.
  - Because no partner bears the economic risk of loss with respect to the liabilities contributed to the partnership, the liability contributed is nonrecourse.
  - There is no net change in the partners' share of liabilities and, thus, no deemed contributions or distributions under section 752(a) and (b) (partnership assumes \$100 of liabilities deemed contributed by X and Y (\$80 and \$20, respectively), and X and Y's share of the liability increases by \$80 and \$20, respectively).
  - X's basis in its partnership interest is \$88 (adjusted basis in assets deemed contributed (\$88) under section 722) and Y's basis in its partnership interest is \$22 (adjusted basis in assets deemed contributed (\$22) under section 722).

## Bargain Purchase



## Basis Allocation in a Bargain Purchase

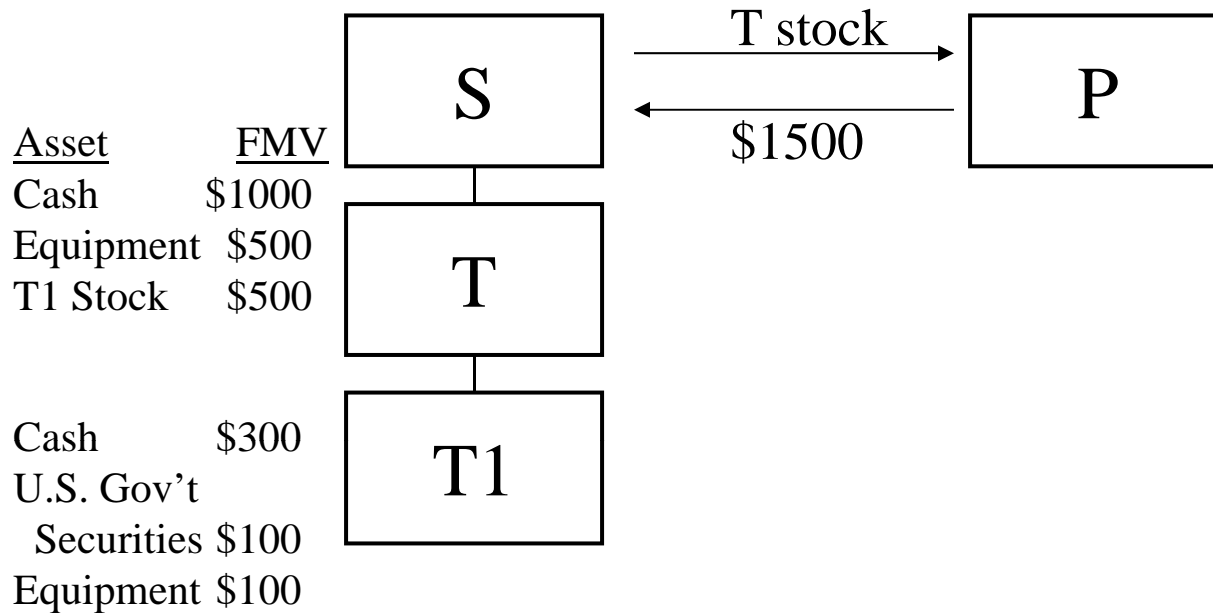

Corporation S owns all of the stock of Corporation T. Because of poor management, T is under strong pressure from S to dispose of its business and liquidate. P is interested in acquiring T's business, but realizes the pressure that T is under, and hence will only pay 75 cents on the dollar for T's assets. T's assets include cash, equipment and the stock of T1, and have a combined fair market value of \$2,000. P purchases the T stock from S for \$1,500 and the parties make joint section 338(h)(10) elections for T and T1.

How will basis be allocated among T and T1's assets under the final regulations?

## Basis Allocation in a Bargain Purchase Continued

Under Treas. Reg. § 1.338-6, basis is allocated under the residual method. Basis is allocated to each class up to its fair market value and then to the next class of assets. Basis is allocated to the assets within a class up to their fair market value (and in proportion to fair market value, if the total is less than their fair market value).

### Class I \$1000

	<u>FMV</u>		<u>Basis</u>
Cash	\$1000		\$1000

### Classes II, III, and IV \$0

None

### Class V \$500

				<u>Basis</u>
Equipment	<u>\$500</u>	x	\$500	= \$250
	\$1000			
T1 Stock	<u>\$500</u>	x	\$500	= \$250
	\$1000			

## Basis Allocation in a Bargain Purchase Continued

### T1 Assets -- Total basis to be allocated \$250

#### Class I \$250

	<u>FMV</u>	<u>Basis</u>
Cash	\$300	\$250

#### Class II \$0

U.S. Gov't Securities	\$100	\$0
--------------------------	-------	-----

#### Class V \$0

Equipment	\$100	\$0
-----------	-------	-----

# Unwanted Assets

# Distribution of Unwanted Assets

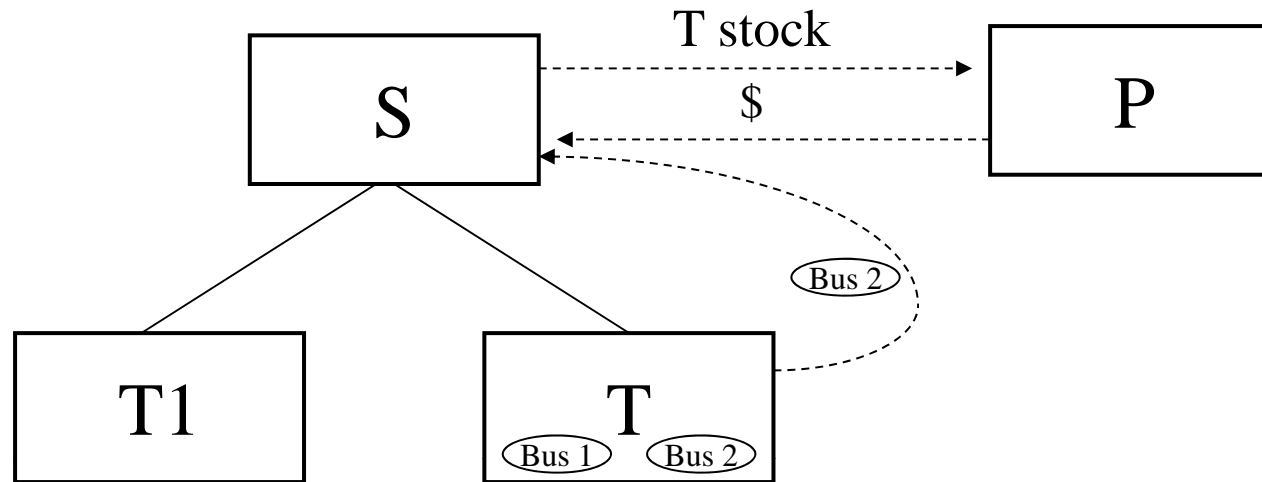

## Facts

Corporation S owns all the stock of Corporations T and T1. T operates Business 1 and Business 2. Corporation P is unrelated to S. P wishes to acquire Business 1 but not the stock or assets of T1 or Business 2.

- T distributes Business 2 to S.
- S sells the T stock to P; S and P make a section 338(h)(10) election.

## Questions

1. Does the sale of the T stock qualify for a section 338(h)(10) election?
2. What are the tax consequences of the distribution of Business 2 to S?

## Distribution of Unwanted Assets Continued

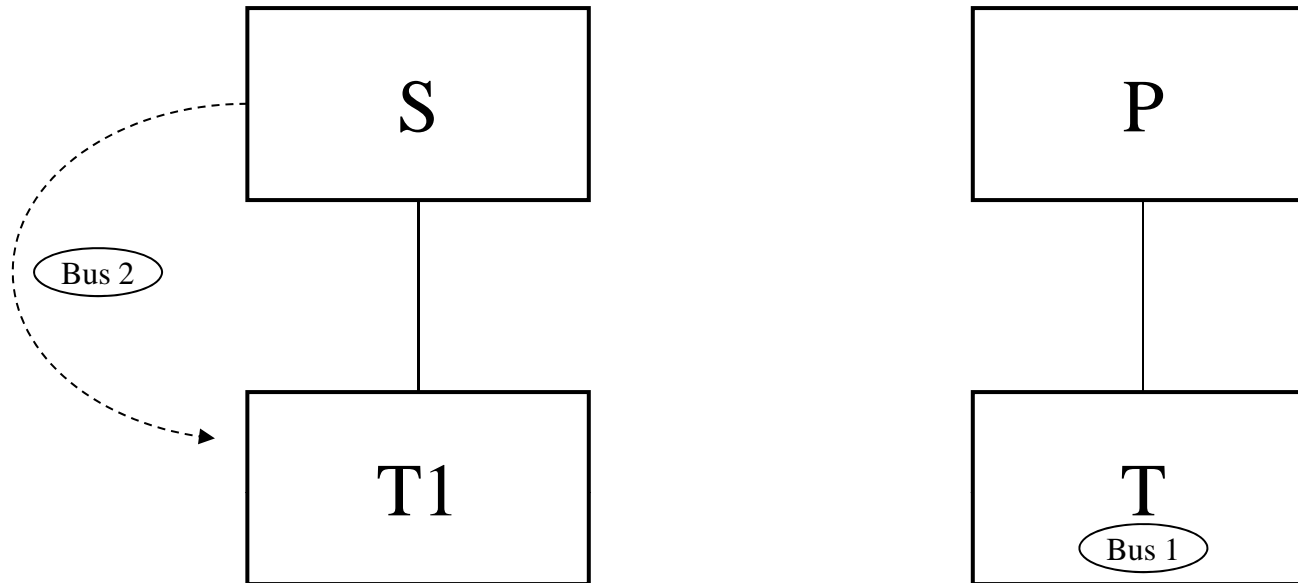

3. What would be the result if, after the distribution by T of Business 2 to S and the stock sale by S, S transferred Business 2 to T1? Would this affect the deemed liquidation under section 338(h)(10)?
4. What would be the result if it were determined that the deemed liquidation was not in fact a complete liquidation?

### References

*Telephone Answering Service Co. v. Commissioner*, 63 T.C. 423 (1974), *aff'd without opinion*, 546 F.2d 423 (4th Cir. 1976), *cert. denied*, 431 U.S. 914 (1977).

Treas. Reg. §§ 1.338(h)(10)-1(d)(4), 1.338(h)(10)-1(e), Ex.2, 1.1502-13(j)(2)

PLR 9738031, PLR 9735038, PLR 9210041, PLR 9137040,

PLR 9044063, PLR 8938036, PLR 8821047

Rev. Proc. 2001-3, 2001-1 I.R.B. 111, § 4.01(24)

## PLR 200934013

### Valuation of LLC Interest – *Pope & Talbot*

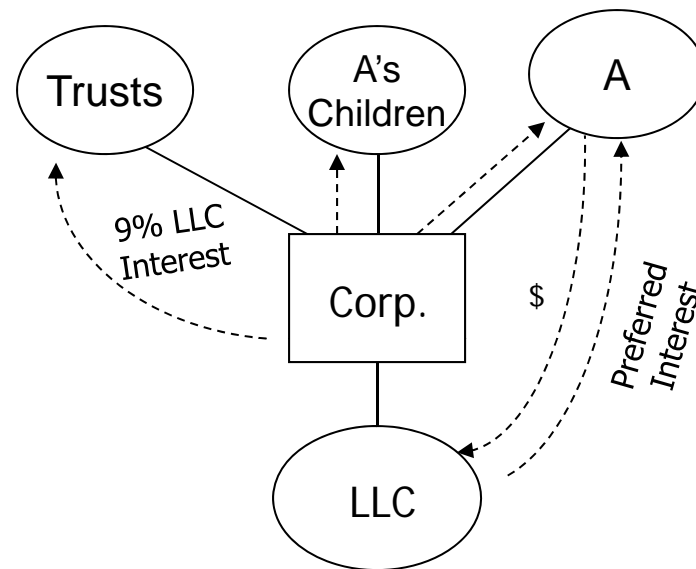

**Facts:** Corp. owned 100% of the interests of LLC, a disregarded entity. On Date 1, shareholder A contributed cash to LLC in exchange for a preferred interest. Corp. proposed to distribute 9% of its LLC interests pro rata to its shareholders, which consisted of individual A, A's children, and trusts for the benefit of A's children and grandchildren.

## PLR 200934013

### Valuation of LLC Interest – *Pope & Talbot*

- Admission of A caused LLC to convert to a partnership, Rev. Rul. 99-5.
- Corp. is deemed to contribute existing assets of LLC to the partnership under Section 721.
- Corp. is deemed to distribute 9% of the LLC interests to its shareholders, recognizing gain under Section 311(b).
  - IRS ruled that Corp.’s basis in the distributed interests equals their proportionate share of Corp.’s adjusted basis in its entire LLC interest.
  - Taxpayer represented that “For purposes of measuring the § 311(b) gain to Corp on the Proposed Transaction, if any, the Distributed LLC interests will be valued as a percentage of the value of the assets held by LLC. *Cf. Pope & Talbot, Inc. v. Commissioner*, 104 T.C. 574 (1995), *aff’d.*, 162 F3d 1236 (9th Cir. 1999).”
- Is it appropriate to look through the LLC to the assets in valuing the distributed interests, but look to the LLC interest in computing their basis?
- *See also Pierre v. Commissioner*, 133 T.C. No. 2 (2009).



## Other Section 338(h)(10) Situations

# Taxable Exchange

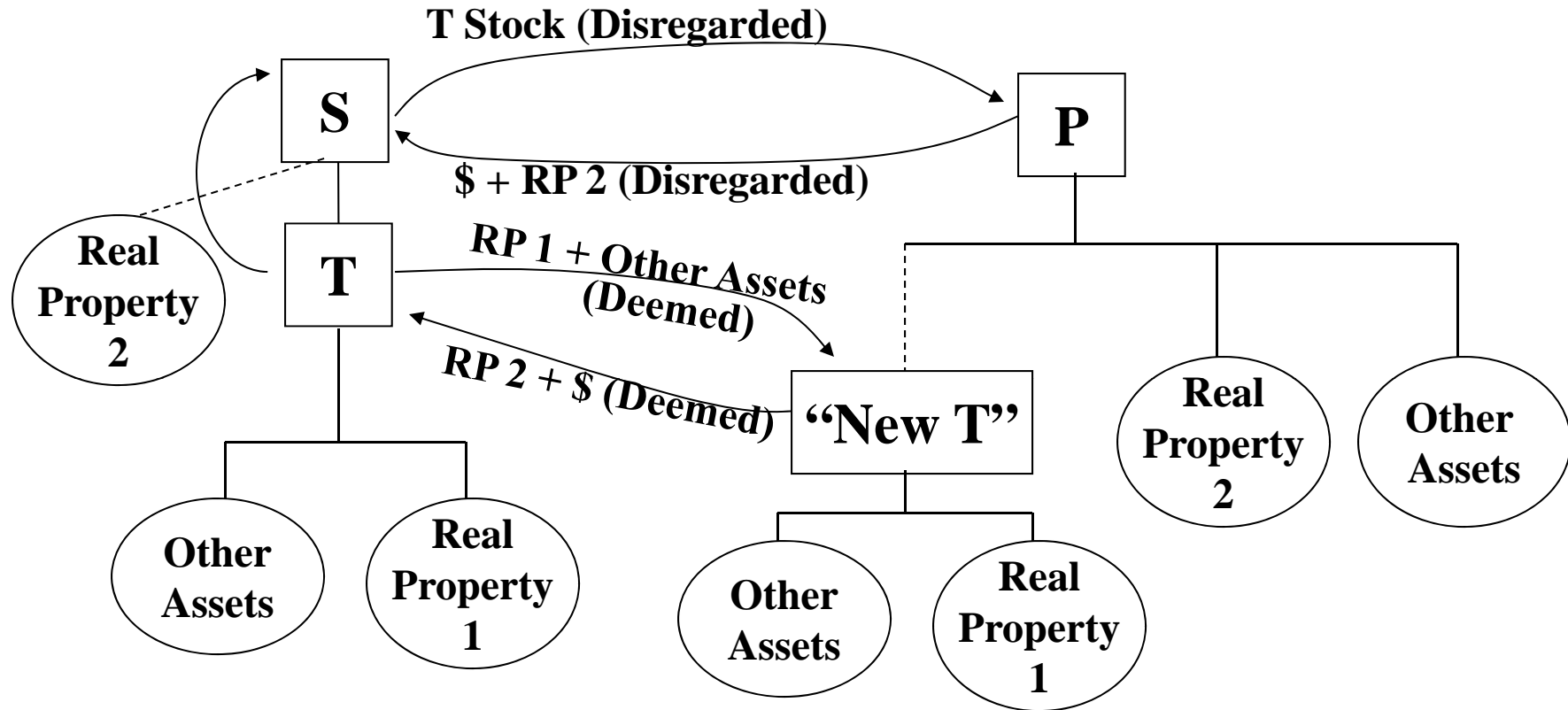

- S owns all the stock of T
- T owns Real Property 1 and Other Assets
- P owns Real Property 2 and Other Assets
- S sells the T stock to P for cash and Real Property 2.
- Can S and P file a section 338(h)(10) election?

Treas. Reg. § 1.338-1(a)(2)

# Retained Stock

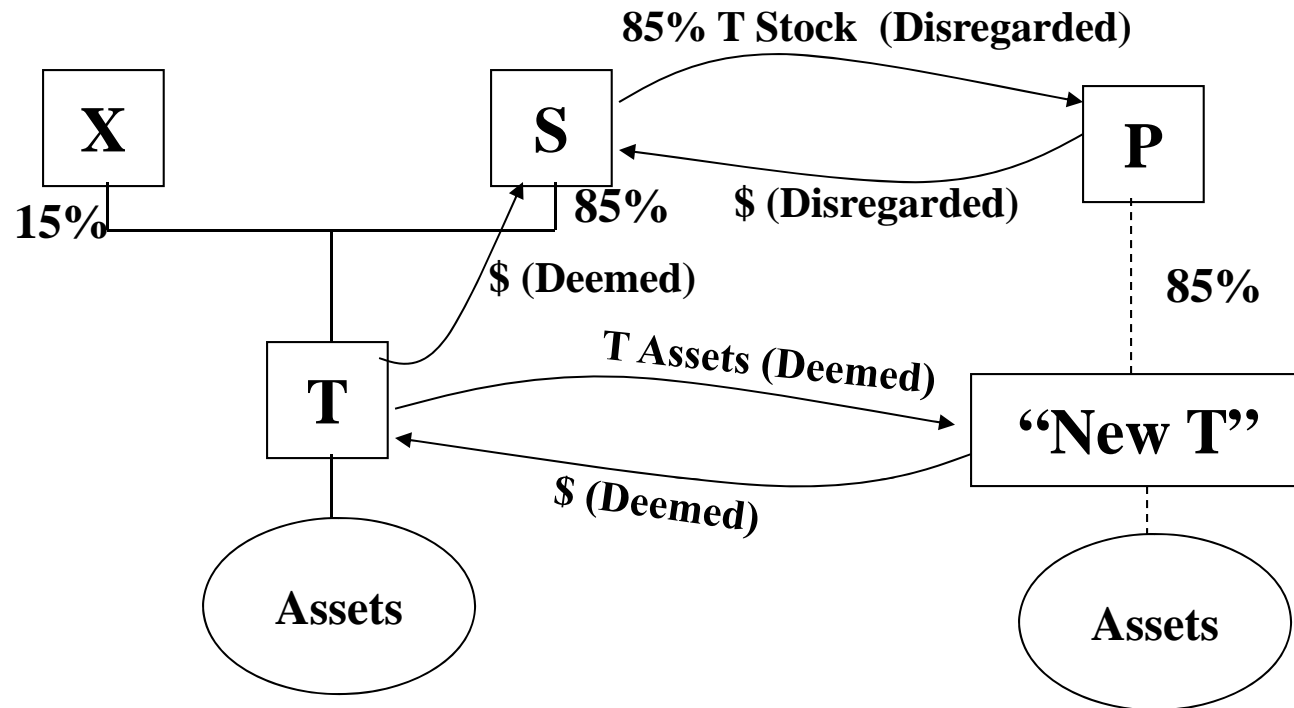

- S owns 85% of the stock of T. S and T file consolidated returns.
- Unrelated X owns the remaining 15% of the T stock.
- S sells its T stock to P. S and P file a section 338(h)(10) election.
- X retains its T stock.
- Variation. X and S are individuals, and T is an S corporation.
- Variation. S owns all the stock of T and sells 85% of the stock to P while retaining the rest.

Treas. Reg. §§ 1.338(h)(10)-1(d)(5), (d)(6), (e) *Examples (6), (7)*

## Acquisition by Minority Shareholder

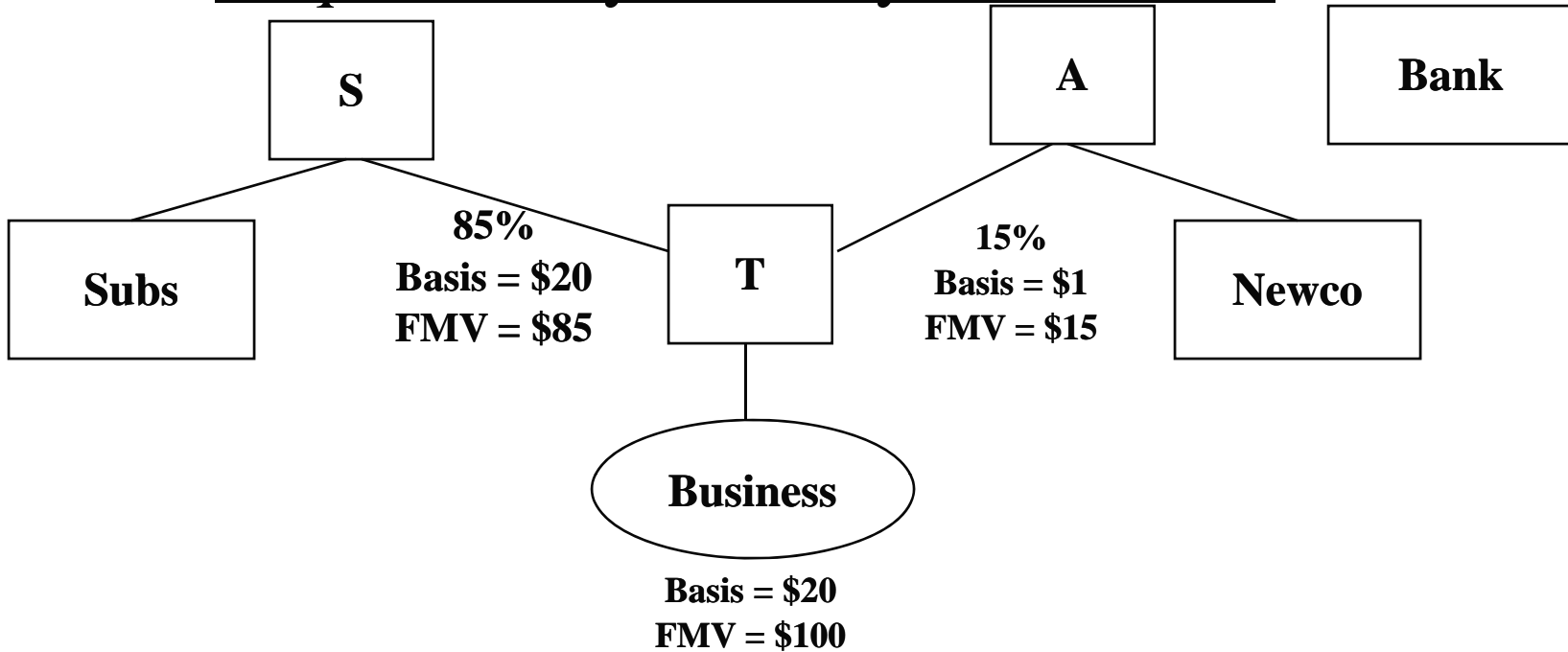

S owns 85% of the stock of T (basis = \$20, FMV = \$85) and files a consolidated return with T and other subsidiaries. T owns Business (basis = \$20, FMV = \$100). A has owned the remaining 15% of the T stock (basis = \$1, FMV = \$15) for several years.

A wants to acquire S's interest in T with a cost basis in T's assets. Alternatives:

1. A buys S's T stock for \$85, with a section 338(h)(10) election. Reg. §§1.338(h)(10)-1(d)(1), 1.338(h)(10)-1(e) *Example (9)*.
2. A forms Newco with \$100 cash. Newco buys the T assets. T liquidates, distributing \$85 to S and \$15 to P. Sections 331, 332.
3. A forms Newco. A contributes \$80 cash for the Newco common stock, and Bank contributes \$5 for Newco preferred stock with 21% of the voting power. Newco buys S's T stock. Sections 338(h)(5) and 338(h)(8).
4. A forms Newco with \$100 cash; Newco uses the cash to buy the T assets; T redeems S's T stock for \$85. Section 302(a); Reg. §1.1502-32. (Suppose S owns 75% and a owns 25% of the T stock?). See also PLR 200551018.

Economic Substance Codification – Impact  
on Section 338

# Economic Substance Codification

- On March 30, 2010, the Health Care and Education Reconciliation Act of 2010, H.R. 4872 (the “Health Care Reconciliation Act”) was signed by President Obama.
  - Section 1409 of the Health Care Reconciliation Act “codified” the economic substance doctrine (the “ES doctrine”).
  - The statute adds new subsection 7701(o), “Clarification of Economic Substance Doctrine.”
  - The statute provides for a strict liability penalty for transactions that lack ES.
- The statute generally applies to transactions entered into after the date of enactment. See section 1409(e) of the Health Care Reconciliation Act.

# Economic Substance Codification

- The Health Care Reconciliation Act does not as a technical matter codify the ES doctrine but rather codifies standards for the ES doctrine, if the doctrine is first determined to be “relevant.” Further, the provision imposes penalties, which is a critical feature of the enactment.
- The codification ultimately results from a combination of influences: (1) it carries a \$4.5B revenue estimate (over 10 years) and so was used to help offset the cost of the health care bill, of which it was a part; (2) eliminates differences among courts in applying the ES standard; (3) politically it is viewed as part of a crack down on abusive taxpayers; and (4) it was a political football, first in favor during the last days of the Clinton administration, then out of favor during the Bush administration, then Senator Obama co-sponsored one of the earlier bills in 2007, then it passed during the Obama administration, after having been included in the President’s 2010 Budget proposal.
- The most thorough official review of the ES doctrine and codification proposals is in JCS-3-09 (Sept. 2009) Description of Revenue Provisions in 2010 Budget, Part Two, pp. 34-72 (“JCT 9/09”).
- The JCT explanation was continuously refashioned as various bills were introduced, ultimately resulting in JCX-18-10 (3/21/2010), with the final bill; see also H. Rep. No. 111-443 (3/17/2010) (describing a prior version of the ES provision, and less detailed, but containing a “reasons for change” section).

# Economic Substance Codification

The JCT 9/09 Description stated the goals of codification as follows:

- provide partial certainty by resolving the lack of uniformity in different judicial versions of the tests;
- possibly lead to more IRS success in asserting ES doctrine by overruling courts that require taxpayers to satisfy only one “prong” of test;
- increase level of profit and business purpose required relative to some tests stated by courts;
- not change the “existing judicial framework” under which applicability of ES doctrine is determined;
- no intent to modify the application or development of other interpretive rules or prevent the IRS from proceeding on multiple grounds;
- change taxpayers’ cost-benefit analysis and deter some aggressive taxpayer behavior; and
- not displace the common law ES doctrine in cases to which the statute is inapplicable (such as individual non business/investment activities).



# Economic Substance Codification

- The statute does not contain certain provisions that were included in prior versions:
  - A statement that other common law doctrines are not affected by codification of the ES doctrine,
  - A grant of general authority to issue regulations to carry out the purposes of the codified ES doctrine,
  - A revision of the penalty rules for certain large and publicly-traded corporations,
  - A prerequisite that a court determine that the ES doctrine is relevant, and
  - A requirement that IRS Chief Counsel assert the strict-liability penalty (which applied to understatements rather than underpayments).

# **Economic Substance – Section 7701(o)**

## New Section 7701(o)

### (o) CLARIFICATION OF ECONOMIC SUBSTANCE DOCTRINE.—

(1) APPLICATION OF DOCTRINE.—In the case of any transaction to which the economic substance doctrine is relevant, such transaction shall be treated as having economic substance only if—

(A) the transaction changes in a meaningful way (apart from Federal income tax effects) the taxpayer's economic position, and

(B) the taxpayer has a substantial purpose (apart from Federal income tax effects) for entering into such transaction.

### (2) SPECIAL RULE WHERE TAXPAYER RELIES ON PROFIT POTENTIAL.—

(A) IN GENERAL.—The potential for profit of a transaction shall be taken into account in determining whether the requirements of subparagraphs (A) and (B) of paragraph (1) are met with respect to the transaction only if the present value of the reasonably expected pre-tax profit from the transaction is substantial in relation to the present value of the expected net tax benefits that would be allowed if the transaction were respected.

(B) TREATMENT OF FEES AND FOREIGN TAXES.— Fees and other transaction expenses shall be taken into account as expenses in determining pre-tax profit under subparagraph (A). The Secretary shall issue regulations requiring foreign taxes to be treated as expenses in determining pre-tax profit in appropriate cases.

## New Section 7701(o)

(3) STATE AND LOCAL TAX BENEFITS.—For purposes of paragraph (1), any State or local income tax effect which is related to a Federal income tax effect shall be treated in the same manner as a Federal income tax effect.

(4) FINANCIAL ACCOUNTING BENEFITS.—For purposes of paragraph (1)(B), achieving a financial accounting benefit shall not be taken into account as a purpose for entering into a transaction if the origin of such financial accounting benefit is a reduction of Federal income tax.

(5) DEFINITIONS AND SPECIAL RULES.—For purposes of this subsection—

(A) ECONOMIC SUBSTANCE DOCTRINE.— The term ‘economic substance doctrine’ means the common law doctrine under which tax benefits under subtitle A with respect to a transaction are not allowable if the transaction does not have economic substance or lacks a business purpose.

(B) EXCEPTION FOR PERSONAL TRANSACTIONS OF INDIVIDUALS.—In the case of an individual, paragraph (1) shall apply only to transactions entered into in connection with a trade or business or an activity engaged in for the production of income.

(C) DETERMINATION OF APPLICATION OF DOCTRINE NOT AFFECTED.—The determination of whether the economic substance doctrine is relevant to a transaction shall be made in the same manner as if this subsection had never been enacted.

(D) TRANSACTION.—The term ‘transaction’ includes a series of transactions.

# **Notice 2010-62**

# Notice 2010-62

- On September 13, 2010, the IRS issued Notice 2010-62, which provides interim guidance under section 7701(o).

## IRS Position on Section 7701(o) Guidance

- Notwithstanding concerns regarding the need for guidance on section 7701(o), the IRS and Treasury “do not intend to issue general administrative guidance regarding the types of transactions to which the economic substance doctrine either applies or does not apply.”
- Further, the IRS will not issue a private letter ruling or determination letter regarding whether the economic substance doctrine is relevant to any transaction or whether any transaction complies with the requirements of section 7701(o).
- Notice 2010-62 provides that “the IRS will continue to analyze when the economic substance doctrine will apply in the same fashion as it did prior to the enactment of section 7701(o).”
  - Thus, according to the IRS, if authorities provided that the economic substance doctrine was not relevant to whether certain tax benefits were allowable prior to the enactment of section 7701(o), the IRS will continue to take the position that the economic substance doctrine is not relevant to whether those tax benefits are allowable.
- The IRS anticipates that the case law regarding the circumstances in which the economic substance doctrine is relevant will continue to develop, and states that the codification of the economic substance doctrine should not affect the ongoing development of authorities on this issue.

## Application of Conjunctive Test

- In Notice 2010-62, the IRS states that it will continue to rely on relevant case law under the common-law economic substance doctrine in applying the two-prong conjunctive test in section 7701(o)(1).
- The IRS will challenge taxpayers who seek to rely on prior case law for the proposition that a transaction will be treated as having economic substance because it satisfies either prong of the two-prong test.

# Notice 2010-62

## Reasonably Expected Pre-Tax Profit

- Under section 7701(o)(2)(A), a transaction's profit potential is taken into account in determining whether the two-prong economic substance test is met if the present value of the reasonably expected pre-tax profit is substantial in relation to the present value of the expected net tax benefits that would be allowed if the transaction were respected for tax purposes.
  - According to Notice 2010-62, the IRS will apply existing relevant case law and other published guidance in performing this calculation.
- The IRS and Treasury also intend to issue regulations pursuant to section 7701(o)(2)(B) on the treatment of foreign taxes as expenses in determining pre-tax profit in appropriate cases.
  - In the interim, the IRS notes in Notice 2010-62 that the enactment of section 7701(o) does not restrict the ability of courts to consider the appropriate treatment of foreign taxes in economic substance cases.

## Accuracy-Related Penalties

- Notice 2010-62 provides details on what constitutes adequate disclosure under section 6662(i) for purposes of reducing the no-fault penalty from 40 to 20 percent.
- The disclosure will be considered adequate under section 6662(i) if made on a Form 8275 or 8275-R, or in a manner consistent with Rev. Proc. 94-69.
- If a transaction lacking economic substance is a reportable transaction, the adequate disclosure requirement under section 6662(i)(2) will be satisfied only if (i) the taxpayer meets the disclosure requirements described above, and (ii) the disclosure requirements under the section 6011 regulations.

# When Does the Doctrine Apply -- In General

- A number of considerations must be taken into account in applying the ES doctrine –
  - Whether the ES doctrine is relevant
    - Does the transaction tested satisfy the terms of the Code and Treasury regulations
    - Whether the benefits claimed are consistent with a Congressional purpose or plan
    - What step(s) of the transaction are to be tested
    - Whether any “safe harbors” can be applied
    - Whether the transaction has been respected under longstanding judicial and administrative practice, based on meaningful economic alternatives based on comparative tax advantages
    - Whether the transaction falls under the exception for individual transactions
  - How the IRS will audit transactions and assert the ES doctrine in light of codification
  - Where the burden of proof will fall on the taxpayers and the IRS
  - Whether it is the ES doctrine that may be relevant (as, for example, compared to other judicial doctrines)
- If the ES doctrine is determined to be relevant, then it must be decided whether the transaction satisfies the codified ES statute:
  - The taxpayer’s economic position must change in a meaningful way
  - The taxpayer must have a substantial non-tax purpose



# When Does the Doctrine Apply -- In General

- Definition of ES doctrine
  - The statute defines the ES doctrine as the “common law doctrine” under which benefits “under subtitle A” are not allowable if the transaction does not have “economic substance or lacks a business purpose.” (emphasis added.) See section 7701(o)(5)(A).
  - What is the purpose of this definition? The statute says that the determination of whether the ES doctrine is relevant shall be made as if the statute was never enacted. See section 7701(o)(5)(C).

# When Does the Doctrine Apply – Congressional Plan or Purpose

- The statute does not define when the doctrine will be treated as relevant.
- Statute and JCT report (JCX-18-10) states that “[t]he determination of whether the economic substance doctrine is relevant to a transaction is made in the same manner as if the provision had never been enacted.”
  - The JCT report further confirms that the provision “does not change present law standards in determining when to utilize an economic substance analysis.”
- Footnote 344 in the JCT report states that “[i]f the realization of the tax benefits of a transaction is consistent with the Congressional purpose or plan that the tax benefits were designed by Congress to effectuate, it is not intended that such tax benefits be disallowed.” (emphasis added.)
  - JCT reports for prior versions of ES codification used the term “clearly consistent.”
  - In effect, the “safe harbor” defines the ES doctrine as applying to tax benefits that IRS perceives not to be consistent with purposes of the particular Code provision the taxpayer relies on for the tax benefits.

# When Does the Doctrine Apply – Congressional Plan or Purpose

- What does being consistent with Congressional purpose or plan mean?
  - Congress may not use language that reflects its intent and purpose.
  - Without an explicit statement by Congress, its intent and purpose may be defined narrowly or broadly.
  - Will the IRS view all benefits that are “unintended” or even “not contemplated” by Congress to be inconsistent with Congressional purpose and intent and subject to the ES doctrine?
  - If a taxpayer satisfies the technical requirements of the Code and regulations, should the ES doctrine apply if no clear statutory purpose or plan is circumvented?
- How does the IRS agent determine the intent or plan?
  - Rev. Proc. 64-22, 1964-1 C.B. 689: “It is the responsibility of each person in the Service, charged with the duty of interpreting the law, to try to find the true meaning of the statutory provision and not to adopt a strained construction in the belief that he is “protecting the revenue.” The revenue is properly protected only when we ascertain and apply the true meaning of the statute.”
  - “The proper method for conveying the positions of the Office and the policies of the Service is through published guidance. In contrast, litigation should be used as an enforcement tool to advance and defend established positions, not as a vehicle for making policy.” I.R.M. 31.1.1.1.3(1).

# When Does the Doctrine Apply – Congressional Plan or Purpose

Application of the ES doctrine to landmark cases won by taxpayers:

- *Cottage Savings Assn. v. Commissioner*, 499 U.S. 554 (1991): Overall transaction of mortgage pool interest swaps had no possible economic profit and no business purpose; motivated entirely by desire for tax benefit of loss recognition, and losses were not booked for accounting purposes. [may be an allowed “longstanding choice” discussed below]
- *Esmark, Inc. v. Commissioner*, 90 T.C. 171 (1988), *aff’d* 886 F.2d 1318 (7th Cir. 1989): Overall transaction had business purpose and economic effect, but arguably not the steps by which Mobil purchased Esmark stock from public, followed by stock’s redemption for stock of Vickers subsidiary of Esmark; not economically different from sale of Vickers by Esmark.
- *Chamberlin v. Commissioner*, 207 F.2d 462 (6th Cir. 1953): No business purpose to distribute preferred pro rata on common, with plan for preferred to be bought by friendly insurance company. Ruled for taxpayer; Congress had to change law (sec. 306).
- *United States v. Cumberland Public Service Co.*, 338 U.S. 451 (1950): Same overall business purpose as in *Gregory v. Helvering*, but no business purpose for step of distributing assets before their sale, allegedly by shareholders; no economic impact of steps on either corporation or shareholders other than tax reduction.
- *Frank Lyon v. United States*, 435 U.S. 561 (1978): Business purpose for Lyon’s seller/lessee (the bank) not to have borrowed the money and built its own building; alleged lease economically similar to that result; no economic savings but tax savings.
- *Gitlitz v. Commissioner*, 531 U.S. 206 (2001): Taxpayer allowed to deduct presumably real losses on account of phantom income providing basis; is this protected from ES doctrine simply because taxpayer and S corp. did not engage in any “transaction” that they could control in the year at issue? Should the timing of the discharge of indebtedness of the S corp in that year have been questioned?

# When Does the Doctrine Apply - Certain Credits

- The JCT report (JCX-18-10) footnote 344 further provides that “it is not intended” that certain tax credits (e.g., section 42, 45, 45D, 47, and 48 credits) be disallowed in a transaction “pursuant to which, in form and substance, a taxpayer makes the type of investment or undertakes the type of activity that the credit was intended to encourage.”
  - The footnote does not cite, but is similar to Rev. Rul. 79-300 (section 183 not applicable to low income housing partnership even though cannot make any money, but depends on tax benefit of losses).
- Does the structure of the investment or the taxpayer’s intent matter if an investment encouraged by Congress is made?
- Does the same standard for credits apply for deductions and other tax benefits?

# When Does the Doctrine Apply – “Safe Harbors”

- According to the JCT report: “The provision is not intended to alter the tax treatment of certain basic business transactions that, under longstanding judicial and administrative practice are respected, merely because the choice between meaningful economic alternatives is largely or entirely based on comparative tax advantages. Among these basic transactions are[:]
  - (1) the choice between capitalizing a business enterprise with debt or equity;
  - (2) a U.S. person’s choice between utilizing a foreign corporation or a domestic corporation to make a foreign investment;
  - (3) the choice to enter a transaction or series of transactions that constitute a corporate organization or reorganization under subchapter C; and
  - (4) the choice to utilize a related-party entity in a transaction, provided that the arm’s length standard of section 482 and other applicable concepts are satisfied.”
- What does the choice between meaningful economic alternatives require?
- Will the IRS expand the list of “safe harbor” transactions?
- Noteworthy that these four “safe harbors” provide taxpayers with the ability to avoid or defer US tax.
- Often, these “safe harbors” may form part of a larger transaction that will (or will not) pass the two prong test in the codified ES statute.

# When Does the Doctrine Apply – “Safe Harbors”

1. The choice between capitalizing a business enterprise with debt or equity --
  - The use of debt is the biggest “tax shelter” there is, due to the interest deduction; why is it excluded? What does this say about perceived Congressional view of debt? Will this be useful in future debt/equity disputes? Does it matter that the creditor is related (not according to later “safe harbor”)?
  - Note that the “safe harbor” applies to using debt to capitalize an entity rather than the use of debt in transactions that the IRS has viewed as “tax shelters” – *e.g.*, *Knetsch*; *Rice’s Toyota*; *ACM*.
  - What is a “business enterprise”? Is the term limited to entities or does it include sole proprietorship -- what if the undertaking being financed is an investment and not a business?
  - Does this “safe harbor” support the disaggregation approach since capitalizing a business enterprise may form part of an integrated transaction that passes the two prong test?
2. A U.S. person’s choice between utilizing a foreign corporation or a domestic corporation to make a foreign investment;
  - Once again, this “safe harbor” shows the ES doctrine dodging the 2nd biggest “tax shelter”: the ability to defer tax on foreign income.
  - Does this mean that the “reality” of foreign corporations will be unquestioned?
    - JCX-18-10 fn. 347 indicates *Bollinger* applies to prevent subsidiary from being parent’s agent except for specific cases.

# When Does the Doctrine Apply – “Safe Harbors”

3. The choice to enter a transaction or series of transactions that constitute a corporate organization or reorganization under subchapter C;
  - How does this square with IRS position when it cites *Caruth*, 688 F. Supp. 1189, for “business purpose” requirement for sec. 351?
  - How about Mrs. Gregory, cited in footnote 348 in JCX-18-10?
  - JCX-18-10 justifies this “safe harbor” by fact that IRS Chief Counsel will not give comfort rulings on these transactions.
  - Does the “choice” for tax-free treatment include transactions structured to avoid such treatment?
  - Are the reasons for protecting reorganizations and organizations the same? Corporate reorganizations are subject to several case law and regulatory anti-abuse rules, and could be viewed as exempt from the economic substance doctrine for that reason. Conversely, a thin set of authority purports to require business purpose for section 351 exchanges and the Treas. Reg. § 1.701-2 anti-abuse rule applies to partnership formation.
  - What about Treas. Reg. § 1.1002-1 strict construction for nonrecognition rules?



# When Does the Doctrine Apply – “Safe Harbors”

4. The choice to “utilize a related-party entity in a transaction, provided that the arm’s length standard of section 482 and other applicable concepts are satisfied.”
  - Why are not all related party transactions particularly suspect?
    - This “safe harbor” appears inconsistent with *Coltec* analysis.
  - Is a related party partnership safer to use than a related party corporation?
  - Doesn’t section 482 rule for intangibles assume that arm’s length prices cannot be trusted between related parties?
  - Does ES doctrine defer totally to section 482?
  - Who determines whether the arm’s length standard and the applicable concepts are satisfied – the IRS, a court?
  - Footnote 349 in JCX-18-10 cites to *National Carbide* and *Moline Properties* and contrasts *Aiken Industries* (back-to-back loans); section 7701(l) and the conduit regulations; and *Bollinger* (losses imputed to shareholder from nominee corporation).
    - Are these examples of the “other applicable concepts” referred to in the footnote?
    - Note Reg. 1.881-3(a)(4) (being related is primary way to trigger conduit financing regs)
    - How about *Gregory, Higgins v. Smith* (sale of loss property to wholly-owned corporation), *McWilliams* (“indirect” sales of loss shares between related parties)?

# When Does the Doctrine Apply -- Disaggregation

- The statute defines the “transaction” as including a series of transactions.
- The JCT report supports not only the aggregation of a series of steps but also a disaggregation of multiple steps to an isolated step.
- According to the JCT report: “The provision does not alter the court’s ability to aggregate, disaggregate, or otherwise recharacterize a transaction when applying the doctrine. For example, the provision reiterates the present-law ability of the courts to bifurcate a transaction in which independent activities with non-tax objectives are combined with an unrelated item having only tax-avoidance objectives in order to disallow those tax-motivated benefits.”
  - The statute as enacted does not provide for a disaggregation approach.
  - The JCT report endorses the *Coltec* approach to disaggregating a transaction in contrast to other authorities. Cf. Notice 98-5; but see *Shell Petroleum* 2008-2 USTC ¶ 50,422 (S.D. Tex. 2008) (refused “slicing and dicing”).
  - Does the JCT report accurately summarize how courts have historically applied the ES doctrine?
    - If not, can the disaggregation approach be squared with the general principle that “present law standards” of applying the ES doctrine not be changed?
    - The IRS will likely assert a narrow definition of the transaction.
    - Will the IRS approach and legislative history lead courts to shift toward a disaggregate approach (i.e., will a court be more likely to disaggregate post-codification as compared to prior periods)?
    - See *Sala v. United States*, 106 AFTR 2d 2010-5406 (10th Cir. 2010) (only the portion of the transaction that gave rise to the loss should be evaluated for economic substance; this is the first appellate case after codification but did not refer to the statute).

# If the ES Doctrine is Determined to be Relevant

## The Two Prong Test --

### The Objective Component

- The transaction must change the taxpayer's economic position in a meaningful way (apart from Federal income tax effects). See section 7701(o)(1)(A).
- The taxpayer can rely on profit potential to satisfy the objective prong only if the “present value of the reasonably expected pre-tax profit from the transaction is substantial in relation to the present value of the expected net tax benefits that would be allowed if the transaction were respected.” See section 7701(o)(2)(A).
  - Satisfaction of the substantial net profit standard in section 7701(o)(2)(A) does not ensure that objective component is met.
  - Note that can rely on profit potential if profit is “reasonably expected” but need to show “actual” economic change to satisfy the objective prong.
  - What else would a taxpayer be required to show? Can a taxpayer satisfy the prong without actual profit?
  - See *Sala v. United States*, 106 AFTR 2d 2010-5406 (10th Cir. 2010) (1:50 profit potential to tax savings not enough on relative basis; this is the first appellate case after codification but did not refer to the statute).

# The Two Prong Test -- The Objective Component

- A taxpayer may rely on measures other than profit potential to establish that the objective prong is satisfied.
  - When would a taxpayer need to rely on an alternative measure to show meaningful change in economic position?
    - Examples given in JCS-3-09, but not in the final JCT explanation: financial transactions and reorganizations may not have quantifiable profit aims.
      - A tax free-reorganization should already fall within the “safe harbor” in the JCT report.
      - What about “financial transactions”? Wouldn’t this normally refer to straddles, hedges, notional principal contracts?
    - Transactions designed to claim tax credits may also present difficulties in proving a pre-tax profit.
      - Like tax-free reorganizations, however, these transactions may have another basis to avoid ES analysis (*i.e.*, consistent with statutory intent and plan).
  - If necessary, how would a taxpayer show a meaningful change in economic position absent profit potential?

# The Two Prong Test -- The Objective Component

- Reliance on pre-tax profit
  - How much profit is required?
    - There is no absolute minimum dollar amount of profit required.
    - However, a small amount of profit may not be treated as substantial in relation to the tax benefits claimed.
  - What does “reasonably expected” mean?
    - JCS-3-09, p. 45, indicates intended to be higher standard than “reasonable possibility,” used in Rice’s Toyota;
    - Note: “reasonable possibility” is too high a standard for sec. 183, which requires only “objective to make a profit”
  - How to calculate present value amounts?
    - What is the appropriate discount rate?
    - Can the taxpayer rely on its normal internal method?
  - What does it mean for net profit to be “substantial” relative to net federal tax benefits?
    - Treas. Reg. § 1.170A-9(f) defines substantial as 1:3.
    - Notice 98-5 – 1:12 and -- 1:8 deemed insubstantial.
    - Old “tax shelter” cases in 1980s – any amount of profit may be sufficient
    - *Con Ed* decided on relatively small profit.

# The Two Prong Test -- The Objective Component

- Reliance on pre-tax profit (con't)
  - Fees and transaction expenses must be counted in determining net pre tax profit. See section 7701(o)(2)(B).
    - Consistent with historic approach to ES doctrine.
  - Statute provides that the Secretary “shall” issue regulations to treat foreign taxes as expenses and transaction fees in “appropriate cases.”
    - Treatment of foreign taxes changed repeatedly during days up to codification: “shall be” treated as expenses, to no reference, to “shall” treat in appropriate cases.
    - JCT explanation (JCX-18-10) indicates belief that foreign taxes should be treated as expenses.
      - However, there is no clarity as to what the “appropriate cases” will be. Transactions described in Notice 98-5?
      - The “shall” delegation in the statute should not be treated as self-executing. But see footnote 357 in JCX-18-10.
    - Cf. Notice 98-5: proposed to deny foreign tax credits to transactions that were not entered into for profit and to deduct foreign taxes as an expense in that analysis; withdrawn by Notice 2004-19.
    - Contra *Compaq* and *IES*, which applied ES doctrine to pre-foreign tax profits.
      - Theory is that US taxes are not counted, and so neither should foreign taxes that are creditable.

# The Two Prong Test -- The Subjective Component

- The taxpayer must have a substantial purpose (apart from Federal income tax effects) for entering into such transaction. See section 7701(o)(1)(B).
  - What was original purpose of this prong in the caselaw? (likely to protect transactions such as incorporation that could not logically be related to profit motive?) Has this purpose been lost?
  - Do courts treat the subjective prong as equal to the objective prong?
  - JCT viewed this as the “dominant issue” and an “absolute requirement.” JCT 9/09
- The taxpayer can rely on the substantial net profit standard to satisfy the subjective prong as well as the objective prong. See section 7701(o)(2)(A).
  - Can the two prongs be collapsed into a single prong? See *Coltec Industries Inc. v. United States*, 454 F.3d 1340 (Fed. Cir. 2006); *Consolidated Edison Co. v. United States*, 90 Fed. Cl. 228 (2009).
  - Note that, as with the objective prong, the satisfaction of the substantial net profit standard technically does not ensure that the subjective prong is satisfied.
    - Is anything else needed to be shown?
  - If there is no substantial non-tax purpose for the transaction, but the transactions results in a substantial profit, is the subjective prong satisfied?
- Who is the taxpayer tested for subjective intent?
  - For example, a partner in a partnership should be the taxpayer. What if the activities or motive in question relate to the other partner or the partnership?

# The Two Prong Test -- The Subjective Component

- What does “substantial” mean?
  - Compare Reg. section 1.701-2(a)(1), the partnership anti-abuse rule, requires a transaction be entered into for a substantial business purpose;
  - Cf. Reg. section 1.355-2(b)(1), which in effect requires a substantial business purpose for a spin-off: a “substantial part” business purpose is thought not to require either a primary or more than 50% purpose; 1/3 purpose seems sufficient.
  - Cf. Reg. section 1.355-2(b)(2), as to non federal tax benefits.
- Financial accounting benefits derived from federal income tax savings and state tax benefits that are related to the federal tax benefits will not be accepted.
  - Accounting benefit concern derived from Enron usage of accounting profits attributable to additions to deferred tax asset account for future expected acquisition of depreciable property, for example.
- Closer to core business the better?
  - Compare *Consolidated Edison Co. v. United States*, 90 Fed. Cl. 228 (2009) (LIFO case won where property leased was used in same business Con Ed was in); *Shell Petroleum, Inc. v. United States*, 2008-2 USTC ¶ 50,422 (S.D. Tex 2008) (property sold was business property)
  - But sec. 7701(o) says nothing about usual course of business transactions.
    - Query: does not fact that Congress chose to make the test a profits test, and to allow it to satisfy both prongs indicate that Congress understands all businesses and investors intend to make money any way they can, and so there should be no “regular course of business” test? Cf. sec. 162.



# ES Doctrine

## Individual Exception

- The statute carves out transactions of individuals unless “entered into in connection with a trade or business or an activity engaged in for the production of income.”
  - As a technical matter, section 7701(o)(5)(B) only excludes “personal transactions” from the two prong test set forth in section 7701(o)(1).
  - Thus, the ES doctrine, as codified, technically can still apply to these transactions. What is the effect?
- The exception presumably would not cover transactions where there is an expectation of gross income (as in sec. 212)
  - Thus, section 212, the section 183 hobby loss rule, and ES doctrine can all apply to activity expected to produce gross income
  - Note that section 183 is much easier for taxpayer to prove out of than ES doctrine (need not even have reasonable expectation of profit)
- Does the exception cover transactions designed to reduce taxes?
  - Charitable contribution planning
  - Estate planning

# **Economic Substance – Strict Liability Penalty**

# ES Codification -- Penalties

## Section 6662(b)(6) (20% accuracy-related penalty)

Any disallowance of claimed tax benefits by reason of a transaction lacking economic substance (within the meaning of section 7701(o)) or failing to meet the requirements of any similar rule of law.

## Section 6662(i) -- INCREASE IN PENALTY IN CASE OF NONDISCLOSED NONECONOMIC SUBSTANCE TRANSACTION

(1) IN GENERAL.—In the case of any portion of an underpayment which is attributable to one or more nondisclosed noneconomic substance transactions, subsection (a) shall be applied with respect to such portion by substituting ‘40 percent’ for ‘20 percent’.

(2) NONDISCLOSED NONECONOMIC SUBSTANCE TRANSACTIONS.—For purposes of this subsection, the term ‘nondisclosed noneconomic substance transaction’ means any portion of a transaction described in subsection (b)(6) with respect to which the relevant facts affecting the tax treatment are not adequately disclosed in the return nor in a statement attached to the return.

(3) SPECIAL RULE FOR AMENDED RETURNS.—In no event shall any amendment or supplement to a return of tax be taken into account for purposes of this subsection if the amendment or supplement is filed after the earlier of the date the taxpayer is first contacted by the Secretary regarding the examination of the return or such other date as is specified by the Secretary.

# ES Codification -- Penalties

## Section 6664(c)(2):

Paragraph (1) [reasonable cause exception for underpayments] shall not apply to any portion of an underpayment which is attributable to one or more transactions described in section 6662(b)(6).

## Section 6664(d):

(2) EXCEPTION.—Paragraph (1) [reasonable cause exception for reportable transaction understatements] shall not apply to any portion of a reportable transaction understatement which is attributable to one or more transactions described in section 6662(b)(6)

## Section 6676(c) (erroneous claim for refund penalty):

(c) NONECONOMIC SUBSTANCE TRANSACTIONS TREATED AS LACKING REASONABLE BASIS.—For purposes of this section, any excessive amount which is attributable to any transaction described in section 6662(b)(6) shall not be treated as having a reasonable basis.

## Section 6662A(e)(2) (coordination of section 6662A penalty with 40% nondisclosed noneconomic substance transaction penalty)

This section [section 6662A] shall not apply to any portion of an understatement on which a penalty is imposed under section 6662 if the rate of the penalty is determined under subsections (h) or (i) of section 6662.

## ES Codification -- Penalties

- The 20% penalty for noneconomic substance transaction applies to any underpayment attributable to the disallowance of claimed tax benefits by reason of a transaction lacking economic substance (within the meaning of section 7701(o)) or *failing to meet the requirements of any similar rule of law*.
  - What is “any similar rule of law”? Not defined in the statute.
  - See JCX-18-10, fn 359: “It is intended that the penalty would apply to a transaction the tax benefits of which are disallowed as a result of the application of the similar factors and analysis that is required under the provision for an economic substance analysis, even if a different term is used to describe the doctrine.”
    - Prior JCT reports did not contain this clarification.
    - Based on JCT report, a “similar rule of law” must mean the disallowance of tax benefits through application of the ES doctrine but not in name (e.g., where the court referred to the ES doctrine incorrectly (perhaps “sham transaction doctrine” or “business purpose doctrine”).
    - The phrase “similar rule of law” should not mean “sham transaction doctrine” or even lack of “economic substance,” when those terms actually refer to fact finding (for example, the business was not actually operated in the corporation), or if they refer to interpreting a requirement into the statute (“business purpose doctrine”) as in case of *Gregory v. Helvering*.
    - Beware of tendency of IRS to view all fact finding methods (step transaction doctrine, etc.) and interpretive methods as “similar rule of law.”

# ES Codification -- Penalties

- 20% Strict Liability Penalty
  - An opinion from an outside tax advisor does not provide protection.
- Calculation of the Penalty
  - The strict liability penalty applies to the underpayment attributable to a disallowance of claimed tax benefits by reason of a transaction lacking economic substance.
    - What is the connection between the assessment and disallowance required? “But for” standard?
  - Prior versions of ES contained penalties based on understatement (i.e., under section 6662A).
  - The section 6662A penalty may apply to a non-ES transaction if it is a listed transaction or reportable transaction with significant purpose of tax avoidance or evasion. See section 6662A(b)(2).
    - The section 6662 penalty normally only applies to the excess of the substantial understatement over the reportable transaction understatement. See section 6662A(e)(1).
    - If the transaction is not disclosed and the 40% strict liability penalty applies, then the section 6662A penalty will not apply to that portion of the understatement. See section 6662A(e)(2)(B).

# ES Codification -- Penalties

- Coordination with the fraud penalty
  - The strict liability penalty does not replace the fraud penalty (a 75% penalty on the underpayment). See section 6663.
  - The ES penalty will not apply to the extent the fraud penalty applies. See section 6662(b) (flush language)
- Coordination with the gross valuation misstatement penalty
  - Does the section 6662(h) gross valuation misstatement penalty apply in economic substance cases?
- Amended returns
  - Coordination with section 6676
    - The 20% strict liability penalty applies equally if the taxpayer claims benefits on an amended return.
    - Compare treatment of “tax shelters” – reasonable basis to avoid penalty on amended return but MLTN to reduce understatement under section 6662.
  - Cannot disclose a transaction to reduce the strict liability penalty to 20% after first contact.
    - Limitation applies even if examination has not raised the issue of ES.
  - What happens if a taxpayer files an amended return after first contact to claim no tax benefits?

# ES Codification -- Penalties

- 40% penalty
  - Reduced to 20% if taxpayer makes adequate disclosure on return or in statement attached to return.
  - This is same language as used in section 6664(d)(2)(A) with respect to reportable transactions.
    - Under section 6664(d)(2)(A), the relevant facts affecting the tax treatment of the item must be adequately disclosed in accordance with the regulations prescribed under section 6011.
    - The section 6011 regulations provide a form for disclosure of (a) the expected tax treatment and all potential tax benefits, (b) any tax result protection, and (c) describe the transaction in sufficient detail for the IRS to be able to understand the structure and identify the parties.
- IRS assertion of the strict liability penalty
  - Can the IRS assert the ES doctrine and not assert the strict liability penalty?
    - If so, can the IRS then assert the substantial understatement penalty?
  - Can the IRS abate the penalty proportionately to the abatement of the tax? No indication in the bill.
  - What is the last point at which IRS can assert the strict liability penalty? Does it inevitably follow assertion of the ES doctrine and not have to be separately assessed?



# **Economic Substance – LMSB Directive on Imposition of Penalty**

# LMSB Directive

- LMSB directive on penalty imposition
  - On September 14, 2010, the IRS Large and Mid Size Business Division issued a directive on the imposition of a penalty on a transaction lacking economic substance.
  - According to the directive, “[t]o ensure consistent administration of the accuracy-related penalty imposed under section 6662(b)(6), any proposal to impose a section 6662(b)(6) penalty at the examination level must be reviewed and approved by the appropriate Director of Field Operations before the penalty is proposed.”

# **Economic Substance – LB&I Directive**

# LB&I Directive

- On July 15, 2011, the IRS issued an LB&I directive to instruct examiners on how to determine when it is appropriate to seek the approval of the appropriate Director of Field Operations in asserting the codified economic substance doctrine.
- The directive provides that the examiner must develop and analyze a series of inquiries in order to seek approval for the ultimate application of the doctrine in the examination.
  - As a first inquiry, an examiner should evaluate whether the circumstances in the case are those under which application of the economic substance doctrine to a transaction is likely not appropriate.
    - The directive provides a list of facts and circumstances that tend to show that application of the doctrine is likely not appropriate.
  - Second, an examiner should evaluate whether the circumstances in the case are those under which application of the doctrine to the transaction may be appropriate.
    - The directive provides a list of facts and circumstances that tend to show that application of the doctrine may be appropriate.
  - Third, if an examiner determines that the application of the doctrine may be appropriate, the directive provides a series of inquiries an examiner must make before seeking approval to apply the doctrine.
  - Fourth, if an examiner and his or her manager and territory manager determine that application of the economic substance doctrine is merited, guidance is provided on how to request approval of the appropriate Director of Field Operations.

# LB&I Directive

- The directive provides that, until further guidance is issued, the penalties in sections 6662(b)(6) and (i) and 6676 are limited to the application of the economic substance doctrine and may not be imposed with respect to the application of any other “similar rule of law” or judicial doctrine, such as step transaction, substance over form, or sham transaction.
- The directive indicates that the examiner should notify the taxpayer that he or she is planning to perform an economic substance analysis before commencing that analysis, and that if the Director of Field Operations decides to proceed, the taxpayer should be given an opportunity to be heard regarding whether the doctrine should apply.
- Depending on the nature of the transaction, the directive provides for various levels of review of an examiner’s decisions before assertion of the doctrine may proceed.
- In applying the directive, when a transaction involves a series of interconnected steps with a common objective, the term “transaction” generally refers to all of the steps taken together.
  - The directive indicates that in certain circumstances it may be appropriate to analyze separately one or more steps that are included within a series of interconnected steps, such as situations where an integrated transaction includes one or more tax-motivated steps that bear a minor or incidental relationship to a single common business or financial transaction.

# **Economic Substance – Practice and Procedure**

# When Does the Doctrine Apply -- Practice and Procedure

- Does the IRS have to assert the doctrine?
  - The statute only states that the ES doctrine will apply when relevant.
  - Can a court apply the ES doctrine if the IRS does not raise the issue?
    - “..if economic substance as such is not explicitly stated as one of the grounds for disallowance of tax benefits, the application of the companion penalty provisions may be in doubt.” JCS 9/09 at p. 47.
  - Will a court be likely to independently raise the ES doctrine given the strict liability penalty?
- What is the proper time to raise the doctrine?
  - Can the doctrine be raised for the first time in litigation? In appeals?
  - Is RAR expected to be the proper place for assertion of ES doctrine?
  - What legal consequences hinge on timely assertion?
    - Applicability vel non – will the doctrine apply?
    - The burden of proof shifts to IRS in Tax Court if the doctrine is raised after the petition is filed. See Tax Court Rule 142(a).
    - The ES doctrine or any similar rule of law must be asserted in order to apply the 40% penalty (even though a 20% penalty may be applied for a substantial understatement apart from a non-ES transaction).

# When Does the Doctrine Apply -- Practice and Procedure

- How will the IRS administer the ES doctrine
  - What role will LMSB / Chief Counsel have in determinations as to whether tax benefits are (i) consistent with Congressional plan or purpose, (ii) respected under longstanding practice, or (iii) permitted under specified safe-harbors?
    - Should IRS exam make these decisions? Must these decisions be confirmed with LMSB / Chief Counsel?
    - Will LMSB / Chief Counsel provide guidelines to IRS exam?
  - Will taxpayers be able to obtain advance certainty on transactions?
    - There will be a strict liability penalty that cannot be avoided by obtaining opinions from counsel.
    - Will the IRS entertain PLRs? Pre-filing agreements? Technical advice? See Notice 2010-62.



# When Does the Doctrine Apply -- Practice and Procedure

- IRS guidance on ES doctrine
  - Definition of critical terms (e.g., substantial profit, calculation of pre-tax profit, substantial purpose)
  - Clarification of the scope of the ES doctrine –
    - Confirmation that deductions and other benefits treated as credits cited in JCT report
    - Expansion of the four “safe harbors” listed in the JCT report
    - List of general criteria that will not cause the ES doctrine to apply
    - Reliance on anti-abuse rules
      - Should the doctrine be applied when anti-abuse applies and ES doctrine not traditionally at issue?

# When Does the Doctrine Apply -- Practice and Procedure

- How will the IRS audit transactions in practice under the ES doctrine?
  - Assert the doctrine any time the two prong test is viewed as failed
  - Assert the doctrine any time it is relevant
- Default Possibility # 1 -- Assert the doctrine any time the two prong test is viewed as failed
  - Example: IRS auditor concludes transaction (a) resulted in favorable tax reporting; (b) did not have business purpose; (c) was not expected to make much money.
    - Isn't that likely to be the end of the auditor's analysis?
    - Isn't the "relevance" issue likely to be skipped or assumed?
    - Once the deficiency is set up, what realistic opportunity will taxpayer have to prove satisfaction of law as written and prove facts as occurred, or to contest ES doctrine relevance short of court?
    - JCS 9/09 and 2007 S. Rep. say flunking 2 prong test not dispositive, but isn't it likely to work out that way in practice?

# When Does the Doctrine Apply -- Practice and Procedure

- Default Possibility # 1 -- Assert the doctrine any time the two prong test is viewed as failed (con't)
  - In fact, courts do not necessarily determine that the taxpayer's facts satisfy the law as written before applying the ES doctrine, nor do they spend much time analyzing the relevance of the ES doctrine.
    - *Country Pine Finance LLC v. Commissioner*, T.C. Memo. 2009-251 (CARDS case; analysis portion of opinion only involved application of ES doctrine, citing *Am. Elec. Power*)
    - *Am. Elec. Power Co. v. United States*, 326 F.3d 737, 741 (6th Cir. 2003) (rejected trial court “sham in fact” finding, while applying 6<sup>th</sup> Cir. version ES doctrine).
    - Two recent BLISS cases analyze and decide only ES doctrine: *Palm Canyon*, T.C. Memo. 2009-228; *New Phoenix Sunrise Corp.*, 132 T.C. No. 9 (2009).
- Default Possibility # 2 -- Assert the doctrine any time it is relevant
  - Assuming the IRS agent will not tend to assert the ES doctrine unless the agent perceives a tax motivated transaction (which is not hard to perceive), is it likely as a practical matter that the dispute may be over once the “relevance” issue is resolved by the agent/LMSB?
  - IRS Chief Counsel cannot advise agent on the factual analysis specifically.
  - Chief Counsel, or LMSB, or agent, or Appeals determination of relevance will be determinative absent litigation?
- Isn't the threshold decision made by the agent to assert the ES doctrine likely to go unchanged absent litigation?

# When Does the Doctrine Apply -- Practice and Procedure

- Venue
  - Does the choice of circuit matter?
    - The mechanics of the test have been standardized – e.g., conjunctive test.
    - Will judicial application of the codified statute lead to differences between circuits?
      - Will some courts be more reluctant to apply the doctrine given the strict liability penalties?
    - Different circuits treat economic substance as issue of fact or issue of law, which impacts the scope of appeal. See *Sala v. United States*, 106 AFTR 2d 2010-5406 (10th Cir. 2010) (question of law; citing contrary circuits).
  - Will taxpayers choose Tax Court to avoid paying heavy penalties first?
    - Note that, if not raising separate grounds to challenge the penalty, prepayment of the penalty may not be required. See *Shore v. United States*, 9 F.3d 1524 (Fed. Cir. 1993).
    - What grounds are there to challenge the penalty?

# When Does the Doctrine Apply -- Practice and Procedure

- Burden of Proof
  - As to the “consistent with” purposes of the Code, this is a legal issue, not a factual issue.
  - The IRS is asserting a rule contrary to statute and regulations and so should have some sort of burden to justify that.
  - Will *Chevron* deference play a role in the application of the ES doctrine?
  - Even if taxpayer has normal burden of proof as to the two prong test if ES doctrine is asserted, the taxpayer should not be tasked with any burden to counter the IRS’s assertion of the generally applicability of the ES doctrine, but rather the court should carry out its duty to determine the true meaning of the law.

# ES Doctrine – Summary

- The economic substance doctrine is the conflation of statutory interpretation and common law fact finding into a court-made rule of law that, regardless of whether a taxpayer meets all the requirements of the Code and all facts are developed applying relevant common law doctrines, the taxpayer will not prevail if the taxpayer cannot satisfy the subjective and objective standards applied by the courts
  - Congress appears to have glommed onto this court made rule of law to avoid creating one of its own
- The codified ES doctrine requires that the ES doctrine be relevant
- The legislative history identifies two exceptions to the application of the ES doctrine --
  - Whether the benefits claimed are consistent with a Congressional purpose or plan
  - Whether the transaction has been respected under longstanding judicial and administrative practice, based on meaningful economic alternatives based on comparative tax advantages
    - A safe-harbor may be available
- Will the IRS adopt other approaches to determine when the ES doctrine is relevant
  - Adopt a similar approach as under 355(e) regulations – general safe-harbor, specific safe-harbors, factors indicating plan / non-plan
  - What characteristics can be used –
    - Reliance on significantly detailed statute or regulations (e.g., consolidated return regs)
    - Anti-abuse rules that are relevant but satisfied (e.g., Treas. Reg. § 1.701-2; section 269)
    - Involving an area that has been well considered (e.g., election for taxable treatment)
    - Electivity permitted under the law (e.g., a section 332 liquidation, COBE regulations).
- Early guidance from the IRS
  - The IRS must issue early guidance to provide some certainty for taxpayers entering into transactions post-codification – Rev. Rul., Rev. Proc., Announcement
  - The IRS will continue to issue private letter rulings on substantive issues in transactions
    - What level of confidence will these rulings provide for taxpayers on the risk of ES doctrine

# *Coltec* Decision

# Coltec Transaction

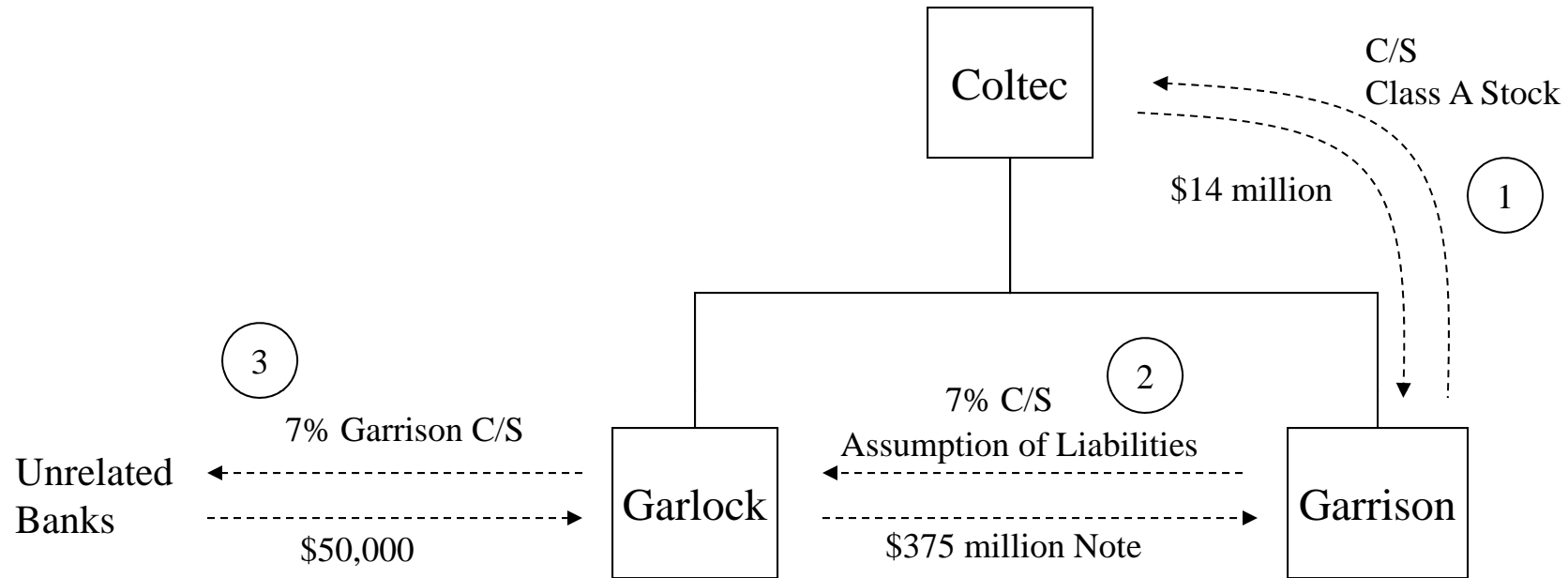

**Facts:** Coltec, a publicly traded company with numerous subsidiaries, sold the stock of one of its businesses in 1996 and recognized a gain of approximately \$240.9 million. Garlock, a subsidiary of Coltec, and its own subsidiary had both previously manufactured or distributed asbestos products and faced substantial asbestos-related litigation claims. Coltec caused another one of its subsidiaries, Garrison, to issue common stock and Class A stock to Coltec in exchange for approximately \$14 million. In a separate transaction, Garrison issued common stock to Garlock that represented approximately a 6.6% interest in Garrison and assumed all liabilities incurred in connection with asbestos related claims against Garlock, as well as the managerial responsibility for handling such claims. In return, Garlock transferred the stock of its subsidiary, certain relevant records to the asbestos-related claims, and a promissory note (from one of its other subsidiaries) in the amount of \$375 million. Garlock then sold its recently acquired Garrison stock to unrelated banks for \$500,000. As a condition of sale, Coltec agreed to indemnify the banks against any veil-piercing claims for asbestos liabilities. On its 1996 tax return, Coltec's consolidated group claimed a \$378.7 million capital loss on the sale of Garrison stock, which equaled the difference between Garlock's basis in the stock (\$379.2 million) and the sale proceeds (\$500,000).



# Coltec Decision – Court of Federal Claims

- The Court of Federal Claims entered a decision after trial in favor of Coltec, upholding the capital loss claimed by Coltec from the contingent liability transaction at issue in this tax refund litigation. See *Coltec Industries, Inc. v. United States*, 63 Fed. Cl. 716 (2004).
- The Court of Federal Claims relied on the District Court analysis in *Black & Decker* (discussed below) to hold that the operation of the applicable code sections justified a capital loss.
  - The contribution of assets in exchange for stock and the assumption of the liabilities qualified as a nontaxable exchange under section 351.
  - Under section 358, the transferor received a basis in the stock equal to the basis of the assets contributed. Ordinarily, when a transferee in a section 351 exchange assumes liabilities of the transferor, the transferor's basis in the transferee's stock is reduced by the amount of the liabilities. However, under sections 358(d)(2) and 357(c)(3), if the satisfaction of the liabilities would have given rise to a deduction to the transferor, the assumption of such liabilities does not reduce basis. Because satisfaction of the liabilities assumed by the transferee would have given rise to a deduction to the transferors (had the liabilities not been transferred), the basis of the stock is not reduced by the liabilities assumed under section 358(d)(2). After the transfer, payment of the liabilities would give rise to a deduction by the transferee. See Rev. Rul. 95-74, 1995-2 C.B. 36 (1995). The government argued that section 357(c)(3) requires that payment of the liabilities would give rise to a deduction by the *transferor*. The court held that this interpretation was incorrect.
  - In addition, the court held that section 357(b) did not require basis to be reduced because there was a bona fide business purpose for the assumption of the liabilities.

## *Coltec* Decision – Court of Federal Claims

- The Court of Federal Claims rejected the government’s argument that the capital loss should nonetheless be disallowed under the economic substance doctrine.
- The court refused to apply the economic substance doctrine to the transaction because the transaction satisfied the statutory requirements of the Code. The court stated: “[I]t is Congress, not the court, that should determine how the federal tax laws should be used to promote economic welfare.... Where the taxpayer has satisfied all statutory requirements established by Congress, as Coltec did in this case, the use of the ‘economic substance’ doctrine to trump ‘mere compliance with the Code’ would violate the separation of powers.”

## Coltec on Appeal – Federal Circuit

- The Federal Circuit (Judges Bryson, Gajarsa and Dyk) reversed the opinion of the Court of Federal Claims and held that the taxpayer was not entitled to a capital loss because the assumption of the contingent liabilities in exchange for the note lacked economic substance. See *Coltec Industries, Inc. v. United States*, 454 F.3d 1340 (Fed. Cir. 2006).
- The Federal Circuit upheld the technical analysis of the Court of Federal Claims in favor of the taxpayer.
- The court concluded that section 357(c)(3) applies because payment of the liability would give rise to a deduction. The court stated that the government's interpretation that the liabilities must be transferred with the underlying business was plainly inconsistent with the statute.
- The court concluded that if a liability was excluded by section 357(c)(3), then section 357(b)(1) was not relevant. The court reasoned that the exception in section 358(d)(2) for liabilities excluded under section 357(c)(3) does not contain any reference to section 357(b), nor does section 357(b) contain any reference to the basis provisions in section 358.

## Coltec on Appeal – Federal Circuit

- However, the Federal Circuit reversed the Court of Federal Claims decision with respect to economic substance and held that the transfer of liabilities in exchange for the note should be disregarded.
- The Federal Circuit identified five (5) principles of economic substance.
  - The law does not permit the taxpayer to reap tax benefits from a transaction that lacks economic reality;
  - It is the taxpayer that has the burden of proving economic substance;
  - The economic substance of a transaction must be viewed objectively rather than subjectively;
  - The transaction to be analyzed is the one that gave rise to the alleged tax benefit;
  - Arrangements with subsidiaries that do not affect the economic interests of independent third parties deserve particularly close scrutiny.

## Coltec on Appeal – Federal Circuit

- In applying the economic substance test, the Federal Circuit focused solely on the transaction giving Coltec the high stock basis (i.e., the assumption of the liabilities in exchange for the note) and concluded that Coltec had not demonstrated any business purpose for that transaction.
- The court rejected Coltec's claim that it would strengthen its position against potential veil-piercing claims, since it only affected relations among Coltec and its own subsidiaries and had no effect on third parties.

# Coltec Certiorari Petition

- Coltec filed a petition requesting certiorari with the Supreme Court.
- One of the two questions presented for review in the cert petition relates to the disjunctive vs. conjunctive nature of the economic substance test and the current circuit split.
  - The cert petition stated the question as follows: "Where a taxpayer made a good-faith business judgment that the transaction served its economic interests, and would have executed the transaction regardless of tax benefits, did the court of appeals (in acknowledged conflict with the rule of other circuits) properly deny the favorable tax treatment afforded by the Internal Revenue Code to the transaction based solely on the court's "objective" conclusion that a narrow part of the transaction lacked economic benefits for the taxpayer?"
- The other question presented for review in the cert petition relates to the standard of review in economic substance cases.
  - The cert petition stated the question as follows: "In determining that a transaction may be disregarded for tax purposes, should a federal court of appeals review the trial court's findings that the transaction had economic substance de novo (as three courts of appeals have held), or for clear error (as five courts of appeals have held)?"
- Dow Chemical Co. filed a cert petition on October 4, 2006 that presented similar questions.
- On February 16, 2007, the Supreme Court denied certiorari in *Coltec* and *Dow Chemical*.

# Recent Economic Substance Decisions

- *Flextronics America, LLC v. Commissioner*, T.C. Memo. 2010-245
  - Issue: Transactions involving transfer of encumbered inventory satisfied literal requirements of section 351, but IRS contended that transactions should be disregarded because they fell outside the purpose of section 351, lacked section 351 business purpose, lacked economic substance, and were subject to disallowance under step transaction doctrine.
  - Holding: Tax Court held transactions were valid, rejecting IRS’s arguments. On economic substance, court held that inventory transactions had economic substance and were legally valid transactions that did what they purported to do.
- *Sundrup v. Commissioner*, T.C. Memo. 2010-249
  - Issue: IRS asserted that certain management services agreements entered into between individuals’ wholly owned entities, as well as transaction between individuals and one such entity, should not be respected for tax purposes. IRS argued that there was no non-tax business purpose for any of the transactions, and that each transaction was without economic substance and a sham.
  - Holding: Tax Court held that transactions lacked economic substance, finding that only intended purpose of the transactions was tax-avoidance.
- *Historic Boardwalk, LLC v. Commissioner*, 136 T.C. 1 (2011)
  - Issue: IRS challenged validity of partnership formed to allow private investor to claim section 47 historic rehabilitation credits in connection with rehabilitation of government-owned property. IRS determined that (i) partnership was sham lacking economic substance that was created for purpose of improperly passing along tax benefits, (ii) investor’s partnership interest was not a bona fide partnership interest, (iii) the property was not actually sold to partnership, and (iv) partnership should be disregarded under partnership anti-abuse rule in Treas. Reg. § 1.701-2(b).
  - Holding: Tax Court rejected IRS’s arguments. With respect to economic substance, court found that investor did not invest in the transaction solely to earn rehabilitation tax credits and rejected argument that transaction did not affect parties’ economic positions. Court also noted that Congress intended section 47 credit to encourage taxpayers to invest in rehabilitation projects that would otherwise produce little or no profit.
- *Superior Trading, LLC v. Commissioner*, 137 T.C. 70 (2011)
  - Issue: IRS challenged validity of transactions producing losses through foreign entity’s contribution of distressed receivables to partnership.
  - Holding: Tax Court declined to apply economic substance doctrine, stating that it could “safely address [transaction’s] sought-after tax characterization without resorting to sweeping economic substance arguments.” Court held that relevant entity was not a valid partnership and that a sale, rather than a contribution to such partnership, had taken place, and applied the substance-over-form and step transaction doctrines.

# Recent Economic Substance Decisions (cont'd)

- *WFC Holdings Corp. v. United States*, 2011-2 USTC ¶ 50,650 (D.C. Minn. 2011)
  - **Issue:** IRS challenged transaction similar to those in *Coltec* and *Black & Decker Corp. v. United States*, 436 F.3d 431 (4th Cir. 2006), with taxpayer claiming capital loss based on position that transfer/assumption of liabilities in section 351 exchange did not reduce the basis in stock received by taxpayer under sections 358(d)(2) and 357(c)(3).
  - **Holding:** District court found that transaction satisfied technical requirements of Code, but that transaction lacked economic substance. Court held transaction lacked a legitimate business purpose aside from tax benefits and did not have objective economic substance.
- *Pritired I, LLC v. United States*, 2011-2 USTC ¶ 50,654 (S.D.C. Iowa 2011)
  - **Issue:** IRS disallowed foreign tax credits claimed through partnership formed to invest in two French entities. IRS determined (i) transaction was properly characterized as a loan and therefore no partnership existed, (ii) transaction lacked economic substance, and (iii) transaction violated partnership anti-abuse rule.
  - **Holding:** District court agreed with IRS determinations, holding that transaction was in substance a loan and that partnership violated the requirements of partnership anti-abuse rule. On economic substance, court determined that transaction had no credible business purpose other than to generate foreign tax credits, and that there was no realistic opportunity to earn a meaningful profit independent of the credits.
- *K2 Trading Ventures, LLC v. United States*, 101 Fed. Cl. 365 (2011)
  - **Issue:** IRS challenged Son-of-Boss transaction similar to transaction in *Jade Trading, LLC v. United States*, 80 Fed. Cl. 11 (2007), *aff'd*, 598 F.3d 1372 (Fed. Cir. 2010).
  - **Holding:** Court of Federal Claims again held for government, disregarding taxpayer's argument that, because the particular spread transactions at issue had some potential for profit (unlike the transaction in *Jade Trading*), the transactions had economic substance. Court found that profit potential is one of several factors a court must look to when assessing economic substance, and that potential for profit alone does not establish economic substance, especially where profit potential is dwarfed by tax benefits. Court found transactions exhibited same attributes that defined strategy as a tax avoidance mechanism in *Jade Trading*.
- *Southgate Master Fund, LLC v. United States*, 659 F.3d 466 (5th Cir. 2011)
  - **Issue:** IRS disallowed losses claimed as a result of transactions involving sale of non-performing loans (NPLs) and sale-repurchase intended to increase partner's outside basis in partnership.
  - **District Court Holding:** District court held for government, relying on judicial doctrines of economic substance, sham partnership, and substance over form. With respect to economic substance, district court held that acquisition of NPLs had economic substance, but that basis producing steps did not.
  - **Fifth Circuit Holding:** On appeal, the Fifth Circuit affirmed the district court's decision. The Fifth Circuit agreed with district court's conclusion that acquisition of NPLs was an economically substantial transaction motivated by a genuine business purpose. However, court found partnership was a sham that must be disregarded for federal tax purposes, and recharacterized transaction as a sale.



# **Economic Substance –Transaction Planning**

## Sale to Recognize Loss

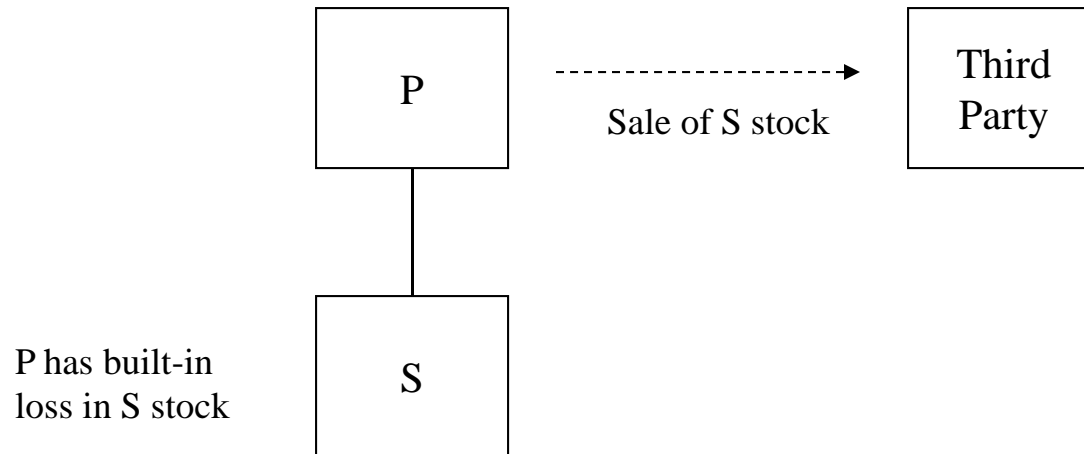

- May a taxpayer sell stock solely to recognize a loss under the Federal Circuit's analysis in *Coltec*? No profit, no business purpose. Presumably not contrary to intent of Congress? How do you know that?
- The Supreme Court in *Cottage Savings* allowed a taxpayer to exchange mortgage securities for other mortgage securities and recognize a loss. The transaction was done solely for tax purposes and was disregarded for regulatory purposes.

## Accelerating a Built-In Gain

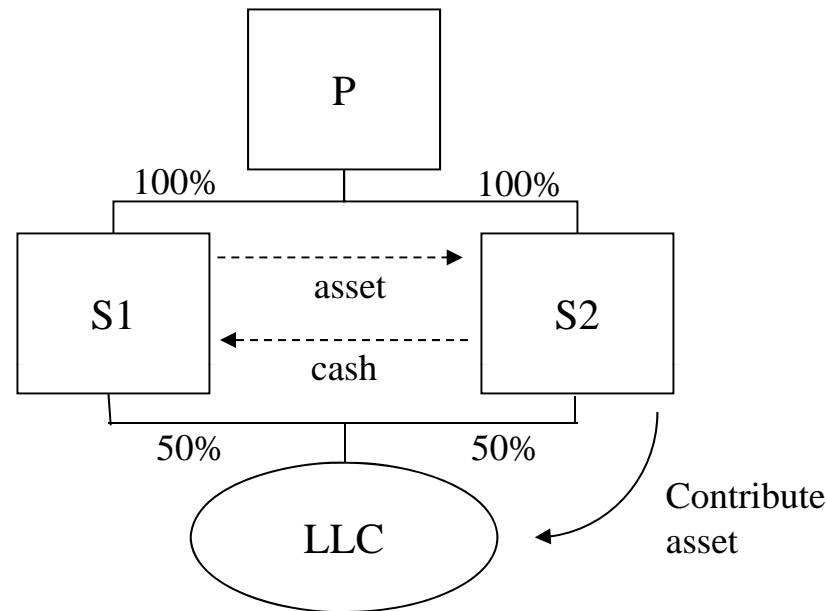

**Facts:** P, a domestic corporation, owns 100% of the stock of S1 and S2, and they file a consolidated return. In Year 1, S1 sells an asset to S2 for cash, resulting in a deferred intercompany capital gain. In Year 3, the P group has a capital loss that it would like to use, so S2 contributes the asset to a newly formed LLC owned by S1 and S2.

**Result:** Because the asset is no longer owned by a member of the P consolidated group, the deferred capital gain should be triggered, which P wants in order to utilize other losses.

**Analysis:** No business purposes, no profit potential from contribution. Contrary to intent of Congress?

## Busting Consolidation -- Example 1

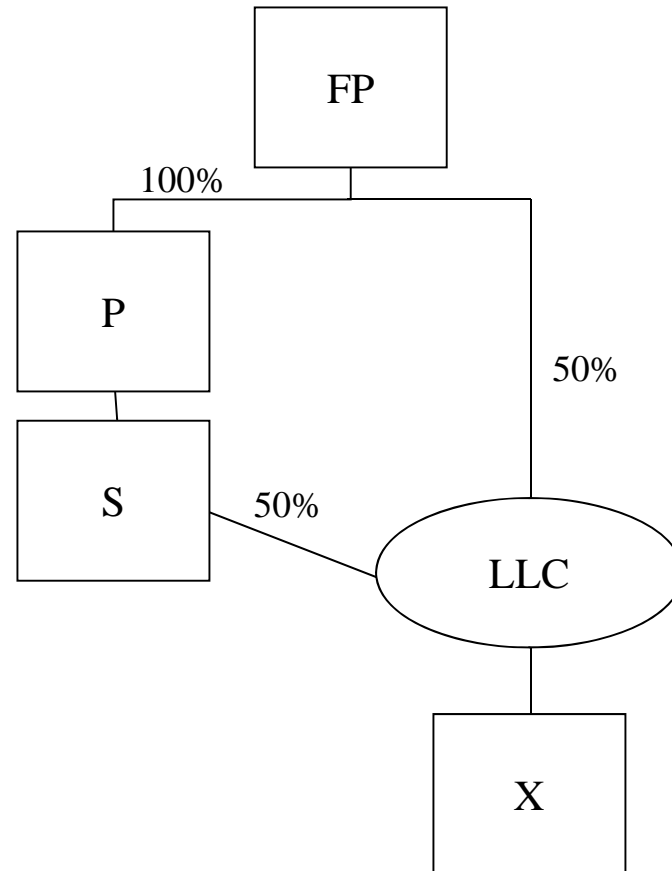

**Facts:** FP, a foreign corporation, owns 100% of the stock of P, which owns all of the stock of S, which owns all of the stock of X. P, S, and X file a consolidated return. In order to deconsolidate X, S contributes the stock of X to an LLC formed by S and FP.

**Result:** Because X is no longer an includible corporation, it should not be a member of P's consolidated group.

**Analysis:** No business purpose and no profit potential.

## Busting Consolidation -- Example 2

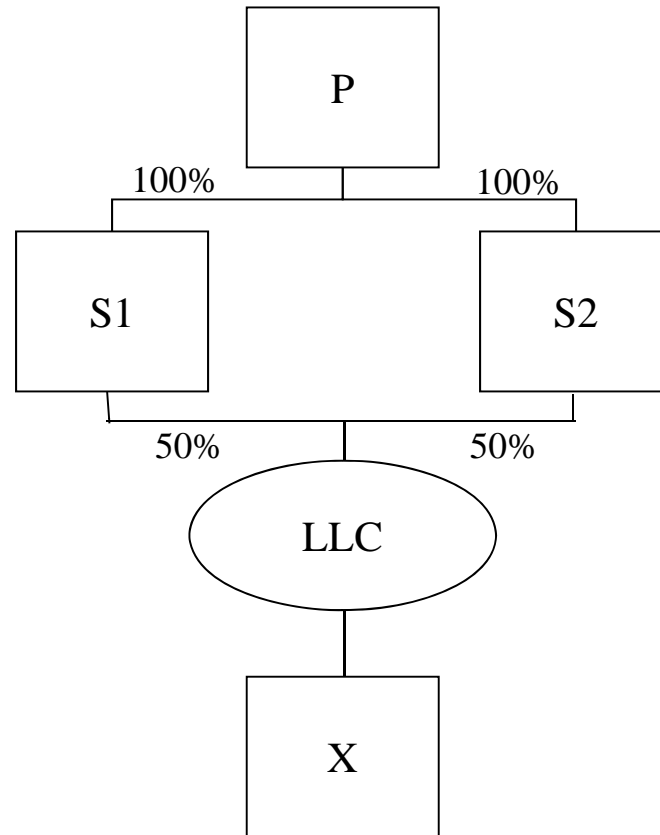

**Facts:** P, a domestic corporation, owns 100% of the stock of S1, S2, and X, and they file a consolidated return. In order to deconsolidate X, P contributes 50% of the X stock to each of S1 and S2, and S1 and S2 contribute the X stock to a newly formed LLC.

**Result:** Because X is no longer an includible corporation, it should not be a member of P's consolidated group. No business purpose and no profit potential.

## Avoiding Loss Disallowance Rules

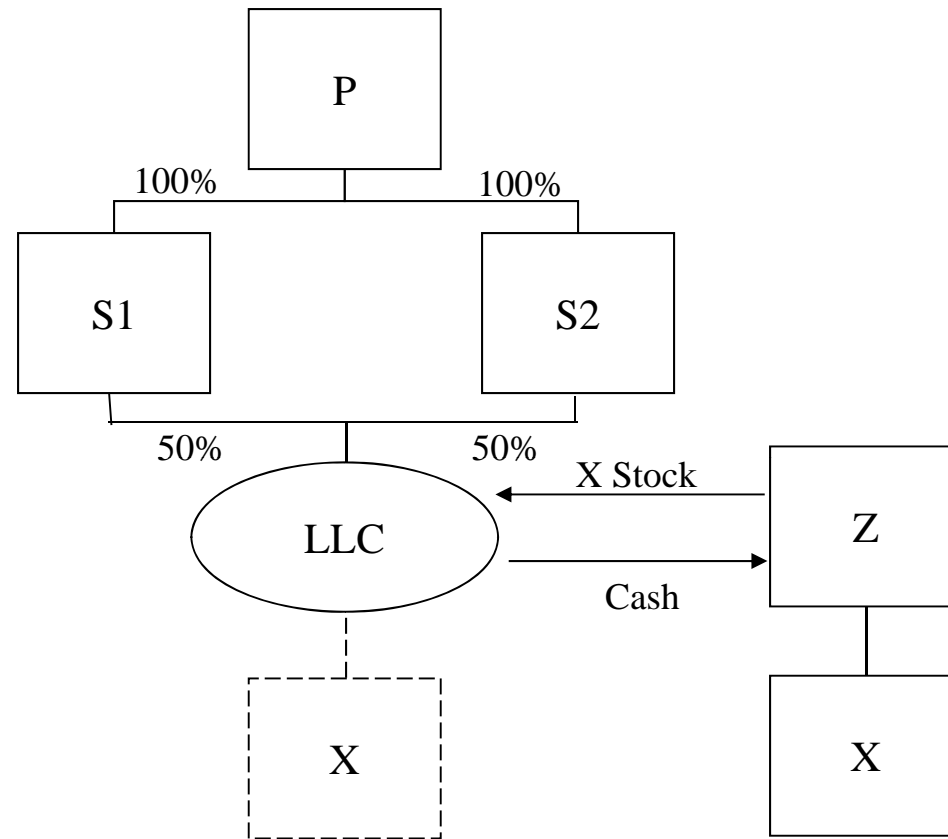

**Facts:** P, a domestic corporation, owns 100% of the stock of S1 and S2. The P group wants to purchase the stock of X from Z, but X has built-in gain assets that could trigger the application of the loss disallowance rules if the P group later disposes of the stock of X. To avoid the potential application of the loss disallowance rules, S1 and S2 form LLC, and LLC acquires the stock of X.

**Result:** Because X is not an includible corporation, it should not be a member of P's consolidated group. The use of the LLC had no business purpose and no profit potential.

## Section 331 Liquidation

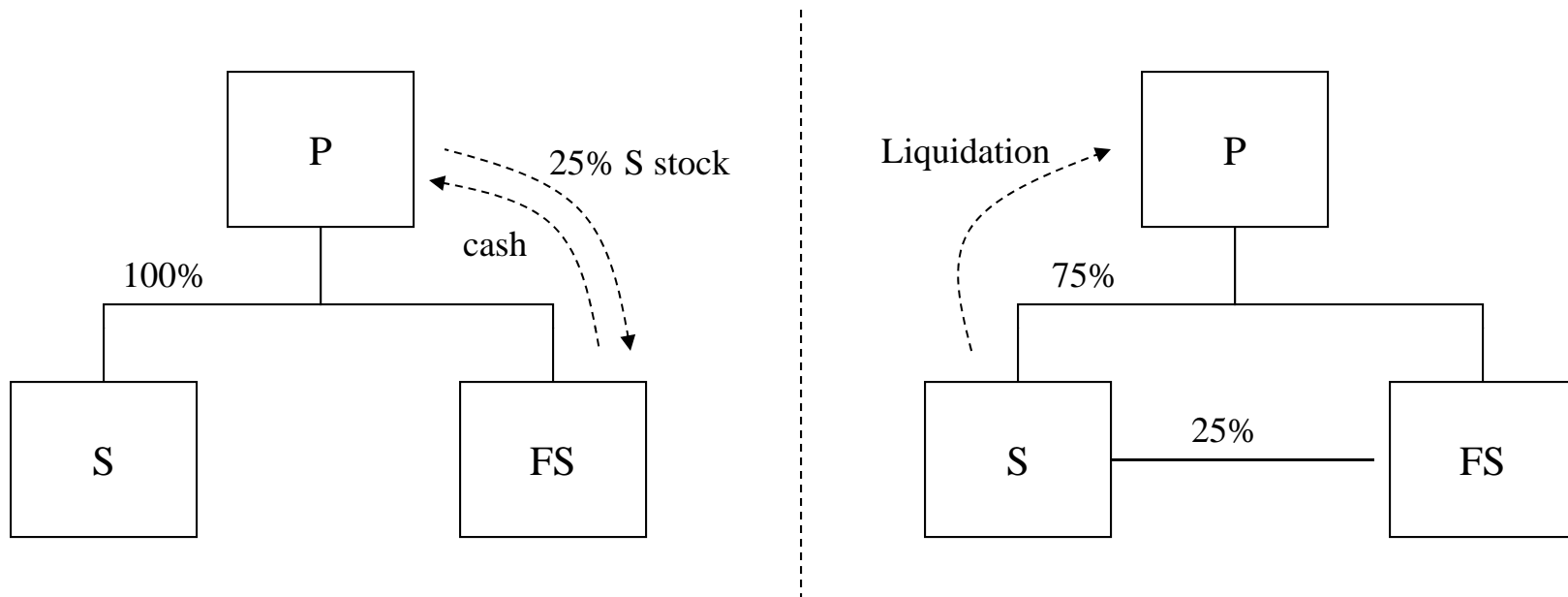

**Facts:** P, a domestic corporation, owns all of the stock of S, which is a domestic subsidiary, and FS, which is a foreign subsidiary. P has a \$100 basis in its S stock. The value of its S stock is \$10. If P liquidates S, the loss in the S stock will not be realized. P therefore sells 25% of the S stock to FS and, after a period of time, S liquidates into P.

**Result:** P should recognize the loss on the remaining 75% of stock in S. There was no business purpose or non-tax profit potential for the division of ownership.

## Section 332 Liquidation

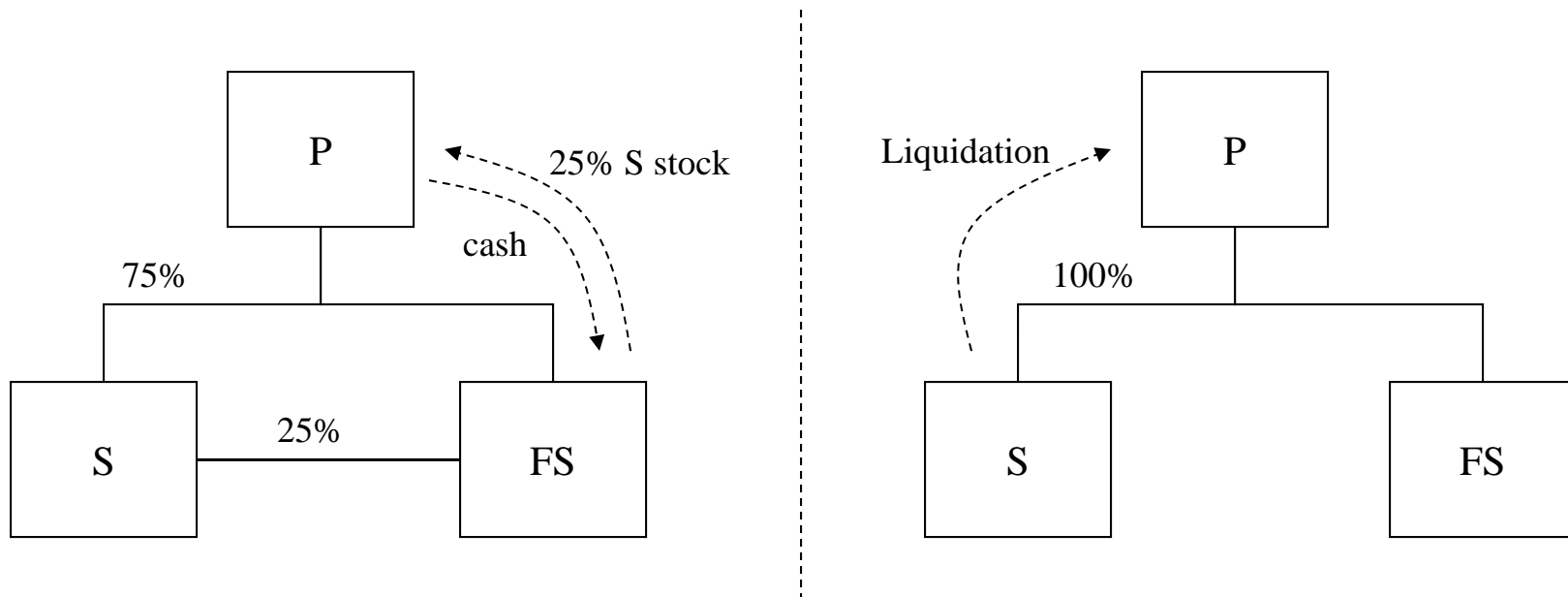

**Facts:** P, a domestic corporation, owns 75% of the stock of S, which is a domestic subsidiary, and 100% of FS, which is a foreign subsidiary. P has a \$10 basis in its S stock. The value of its S stock is \$100. If P liquidates S, the gain in the S stock will be realized. P therefore purchases 25% of the S stock from FS *before a decision to liquidate is made*, and, after a period of time, S liquidates into P.

**Result:** P should not recognize the gain on the liquidation under section 332. Business purpose and non-tax profit potential?



## Check-and-Sell Transaction

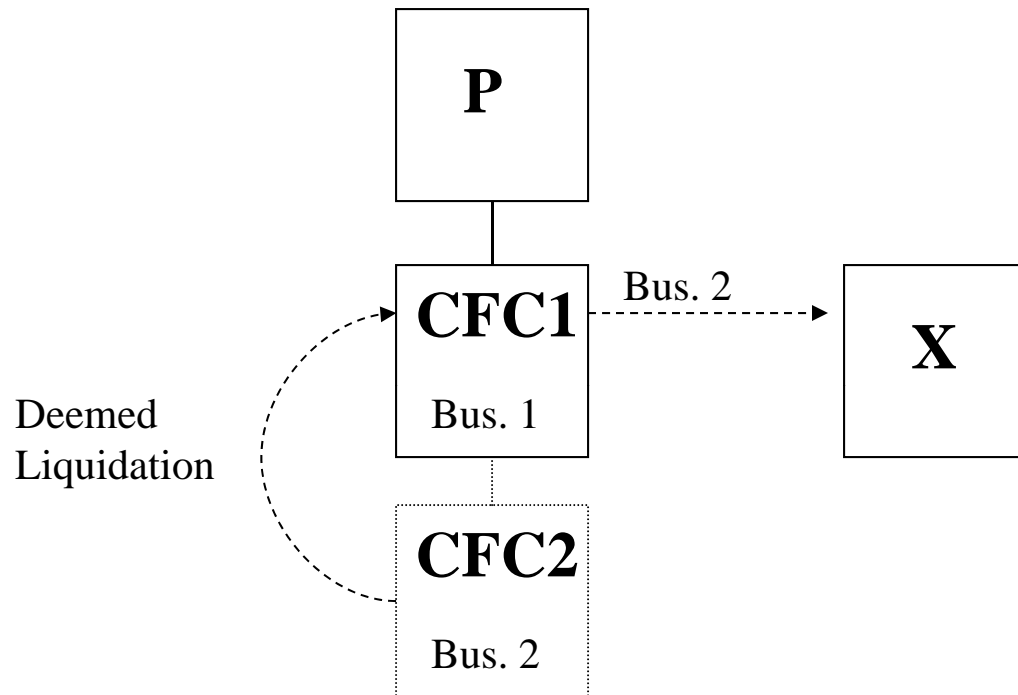

**Facts:** P owns 100 percent of CFC1, which engages in business 1. CFC1 owns 100 percent of CFC2, which engages in business 2. CFC1 and CFC2 are controlled foreign corporations incorporated in the United Kingdom. On Date 1, P causes CFC1 to check-the-box for CFC2, which results in a deemed section 332 liquidation of CFC2. Immediately thereafter, P causes CFC1 to sell all of the assets of business 2 (i.e., CFC2 assets) to X for cash.

**Issue:** Under the rationale of *Dover Corp. v. Commissioner*, 122 T.C. 324 (2004), the income generated from the sale does not constitute Subpart F income. Was there a business purpose or profit potential from checking the box?

# Check-the-box Election to Claim Worthless Security Deduction

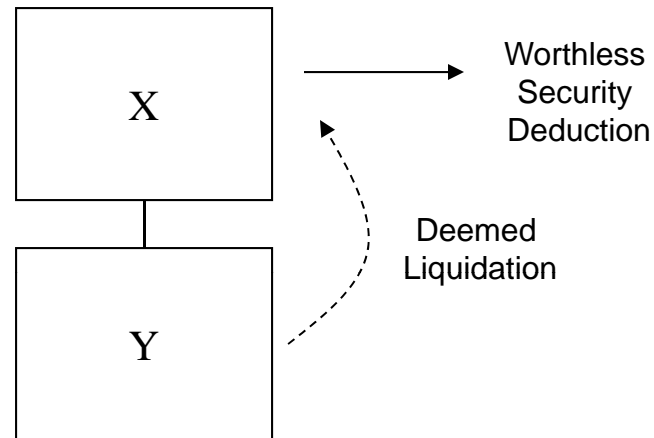

**Facts:** X makes an election to change the classification of Y, a foreign corporation, to a disregarded entity for federal tax purposes. Immediately before the effective date of the election, the fair market value of Y's assets does not exceed the sum of its liabilities.

**Analysis:** Under Rev. Rul. 2003-125, 2003-2 C.B. 1243, X is allowed to claim a worthless security deduction under section 165(g)(3) because the fair market value of Y's assets do not exceed the entity's liabilities (i.e., on the deemed liquidation of Y, X receives no payment on its stock).

**Question:** Is this result affected by the ES doctrine if there was no business purpose for the check-the-box election?

# Checking and Unchecking

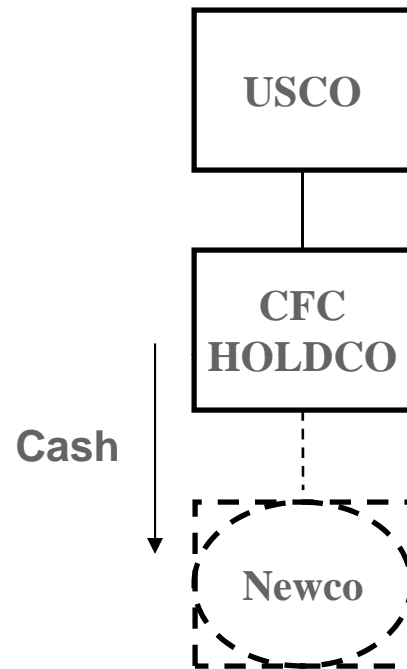

- USCO decides to start doing business in Country A
- USCO already owns CFC Holdco
- CFC Holdco contributes cash into Newco, organized in Country A and makes a check the box election to treat Newco as a disregarded entity

# Use of a blocker to avoid UBTI

## X and Investor Form Partnership

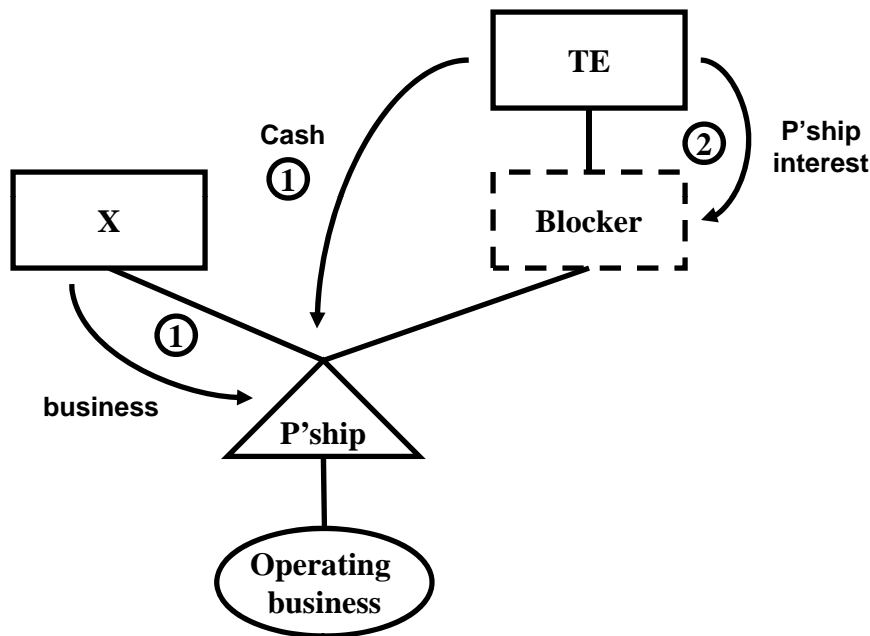

- X owns an operating business that requires additional funds to expand
- Tax-Exempt Investor (“TE”) is interested in making an investment in the X business
  - Income produced by the X business would be UBTI to TE
- X and TE form a partnership, with X contributing its business and TE contributing cash
- TE forms a corporation (“Blocker”) to acquire and hold its investment in the partnership in order to avoid exposure to UBTI

## Purchase and Liquidation

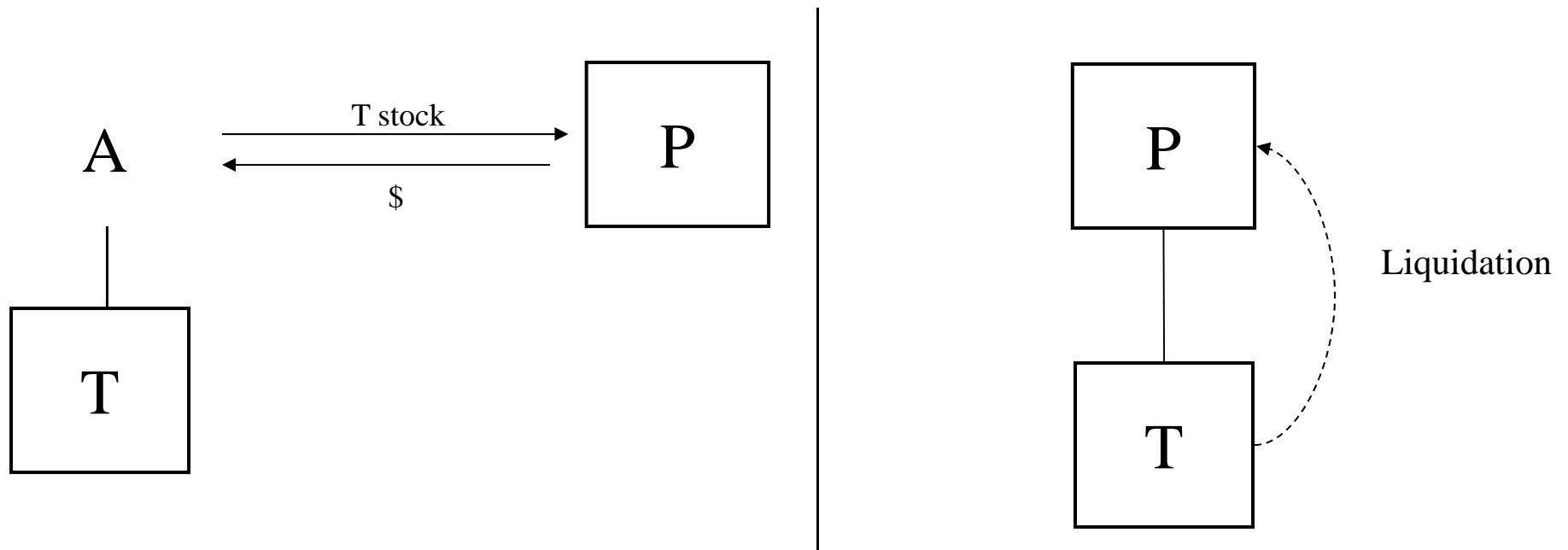

- Section 269(b) states deductions, credits, or other allowances may be disallowed, but only if the liquidation occurs within 2 years after a QSP.
- Does *Coltec* and other recent caselaw replace section 269(b), or mean that a liquidation 2 years and a day after a QSP can result in such a disallowance?

# Liquidation and Sale

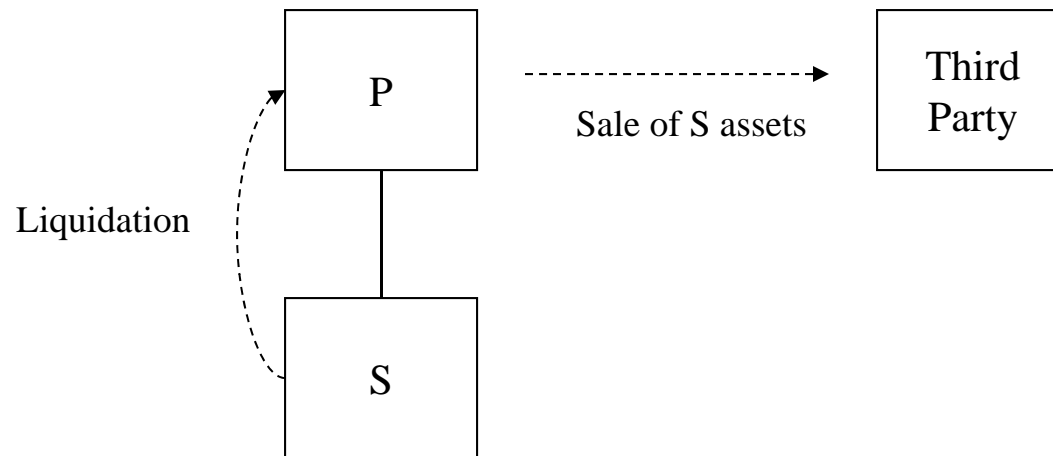

- In *Commissioner v. Court Holding*, the Supreme Court held that a liquidation of a corporation followed by a sale of the corporation's assets resulted in tax to the corporation because "a sale by one person cannot be transformed into a sale by another by using the latter as a conduit through which to pass title." However, five years later, in *United States v. Cumberland Public Service Co.*, the Court held that a liquidation followed by a sale did not result in tax to the corporation. The Court stated, "The subsidiary finding that a major motive of the shareholders was to reduce taxes does not bar this conclusion. Whatever the motive and however relevant it may be in determining whether the transaction was real or a sham, sales of physical properties by shareholders following a genuine liquidation distribution cannot be attributed to the corporation for tax purposes."
- In both *Court Holding* and *Cumberland* the sole purpose of the liquidation was to reduce tax; why did *Cumberland* win? Did the S. Ct. not understand the ES doctrine?

## Section 351 Transaction with Built-in Loss Asset

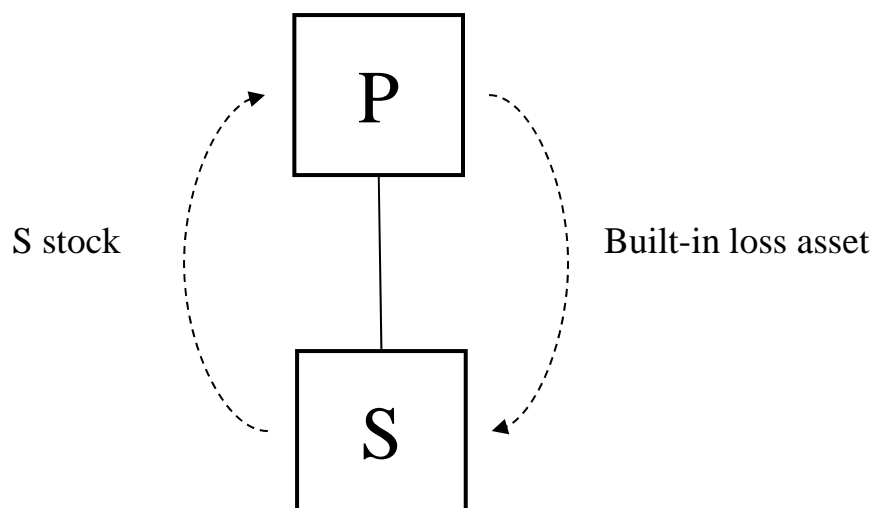

- A corporation transfers an asset with a built-in loss to its subsidiary in exchange for subsidiary stock. Does S hold the transferred asset with a carryover basis and/or does P obtain the S stock with an exchanged basis?
- Is duplicating a loss through a corporation inherently subject to ES doctrine, despite enactment of section 362(e)(2)?
- What if section 362(e)(2) does not apply? See *Shell Petroleum Inc. v. United States*, 2008-2 USTC ¶ 50,422 (S.D. Tex. 2008); *Klamath Strategic Investment Fund v. United States*, 568 F.3d 537 (5th Cir. 2009).

## “C” Reorganization

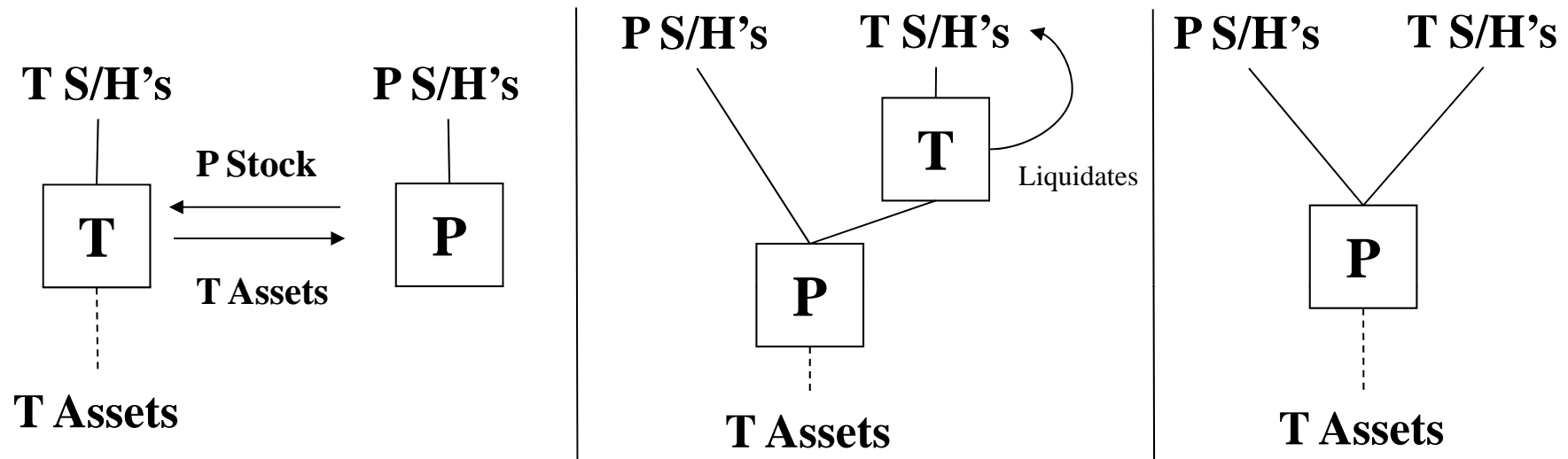

- What if, as is likely the case, certain steps are undertaken solely to come within the reorganization provisions in section 368? For example, assume that substantially all of a target corporation's assets are acquired by another corporation solely in exchange for voting stock. If that corporation liquidates following the asset transaction to come within the terms of a "C" reorganization, is the liquidation step subject to risk because it occurred solely for tax reasons?



## 'D' Reorganizations – Cash – Rev. Rul. 70-240

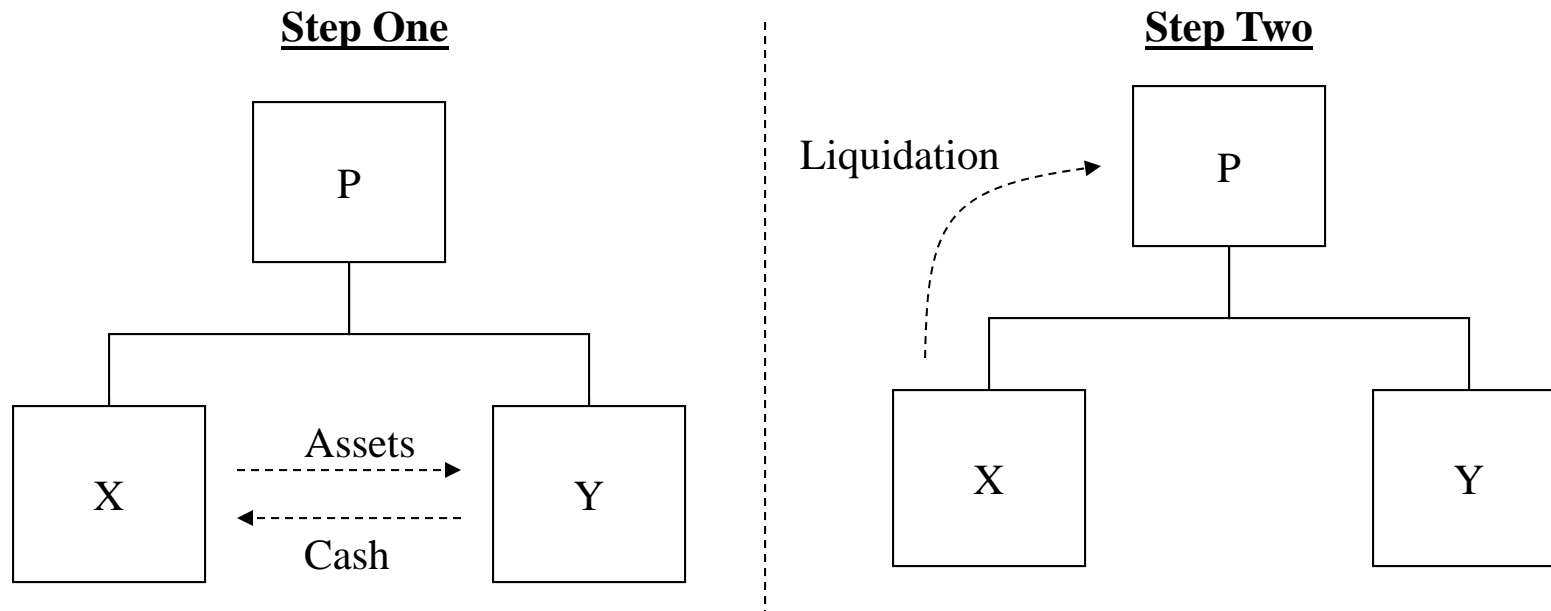

**Facts:** P, X, and Y are corporations. P owns all of the stock of X and Y. X transfers all of its assets to Y in exchange for cash. X then liquidates into P.

**Result:** This transaction qualifies as a tax-free 'D' reorganization under section 368(a)(1)(D), according to Rev. Rul. 70-240.

**Analysis:** Assume the business purpose was to extract cash from Y tax free (under sec. 356, the boot was limited to the gain in the X stock, which here was zero). There was no other business purpose or economic change of ownership.

# All-Cash 'D' Reorganizations – Consolidation

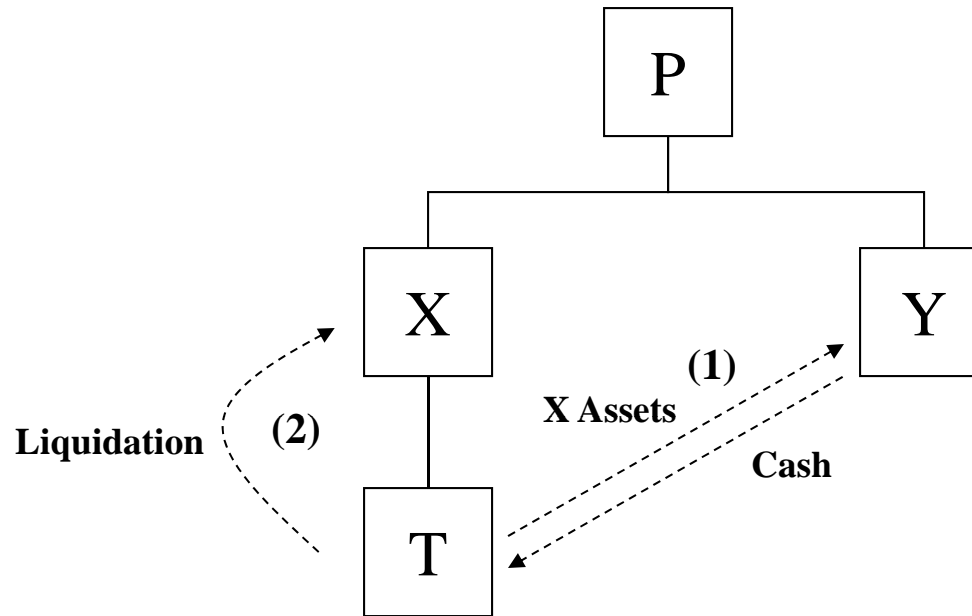

**Facts:** P owns all of the stock of X and Y. X owns the stock of T. P, X, Y, and T are members of a consolidated group. T transfers its assets to Y in exchange for cash and immediately thereafter liquidates into X.

**Result:** In the consolidated return context, the following events are deemed to occur: (i) Y is treated as issuing its stock to T in exchange for T's assets; (ii) T is treated as distributing the Y stock to X in a liquidation; and (iii) Y is treated as redeeming its stock from X for cash. See Treas. Reg. § 1.1502-13(f) and (f)(7), ex. 3.

The final D regulations confirm that the remaining basis or ELA in the Y stock treated as redeemed will shift to a "nominal share" issued by Y. See Treas. Reg. § 1.368-2(l). An ELA will give rise to a deferred gain when the nominal share is treated as distributed from X to P in order to reflect actual stock ownership.

P may be able to avoid this result by having Y actually issue a single share of stock to T or by contributing a share of Y stock to X.

**Question:** Does the issuance of the one share have business purpose or economic substance?

## All-Cash 'D' Reorganizations – Foreign-to-Foreign

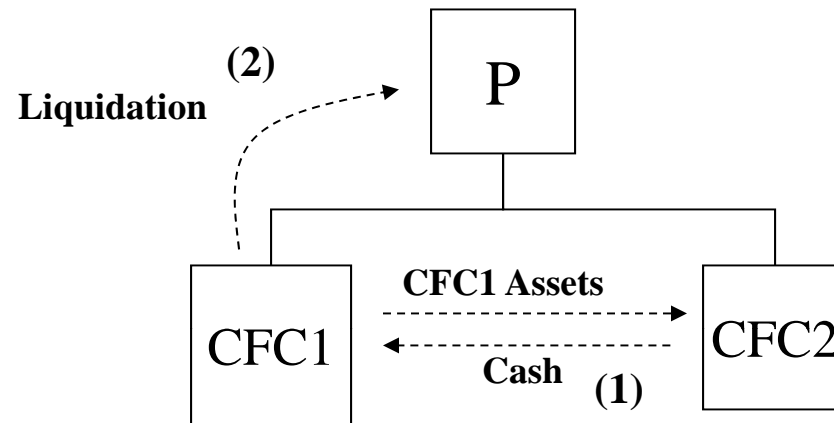

**Facts:** P owns all of the stock of CFC1 and CFC 2. CFC 1 and CFC 2 are foreign corporations. CFC 1 transfers its assets to CFC 2 in exchange for cash and immediately thereafter liquidates into P.

**Result:** This transaction should be treated as a valid “D” reorganization. See Treas. Reg. § 1.368-2(l); but see *Schering-Plough v. Corp. v. United States*, 2009-2 USTC ¶ 50,614 (D.C. N.J. 2009) (implying that efforts to repatriate foreign income without income inclusion will be rejected under the ES doctrine).

## Section 304 Cross-Border Transaction

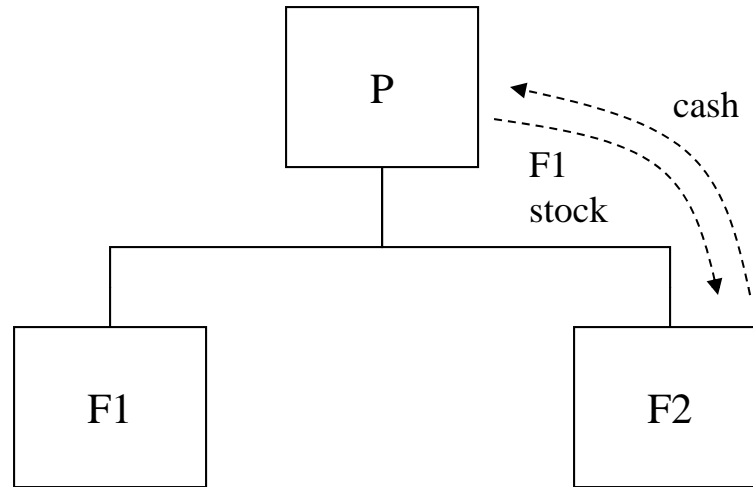

**Facts:** P, a domestic corporation, owns all of the stock of F1 and F2, both of which are foreign corporations. F2 has excess foreign tax credits. P sells F1 stock to F2 in exchange for cash in a transaction the sole purpose of which is to pull foreign tax credits out of F2.

**Result:** Section 304 applies to the transaction so that earnings are repatriated and foreign tax credits are pulled out of F2.

**Question:** Is this result questionable under the ES doctrine because there was no business purpose or profit potential?

## Roll-up Transaction

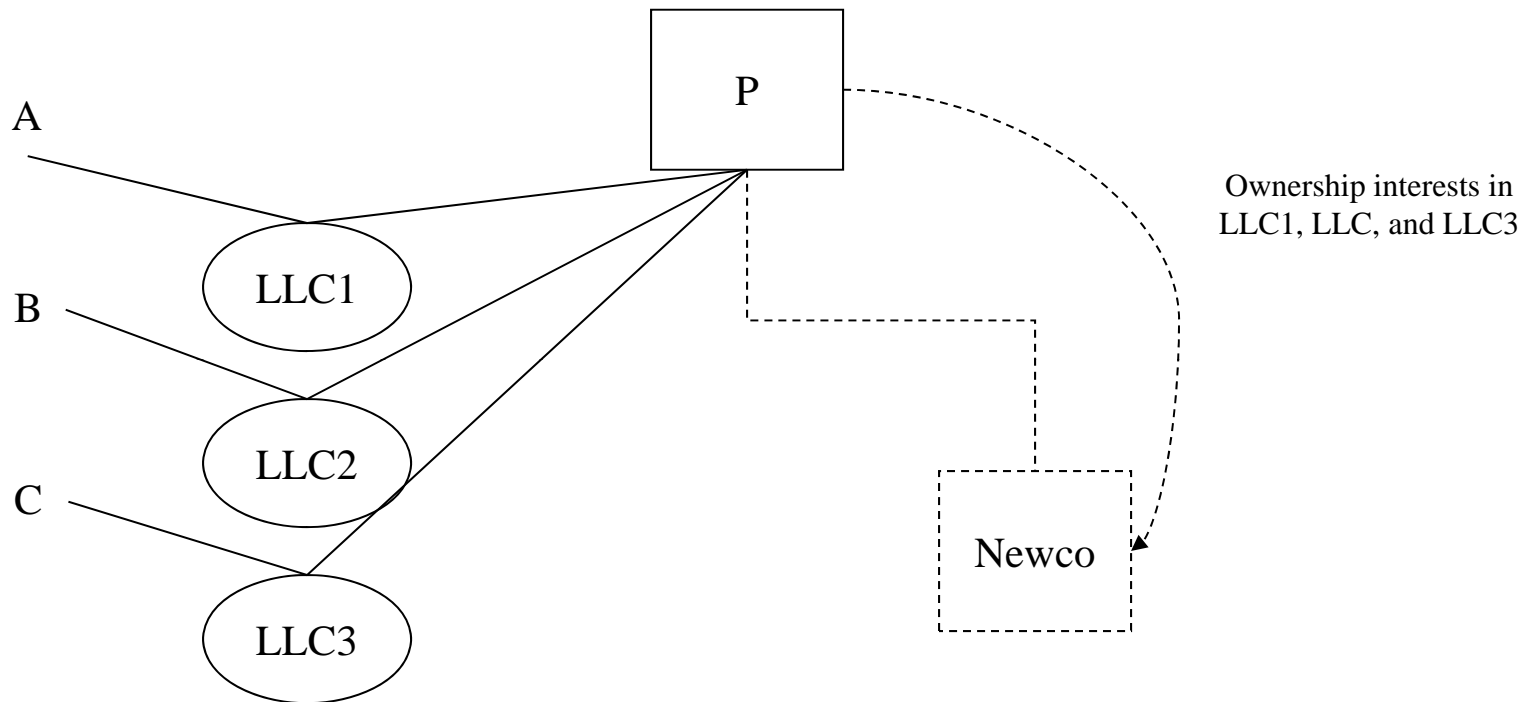

- Assume that a parent corporation converts several LLCs or partnerships into a corporation in a roll-up transaction. Is this transaction subject to review if the roll-up was done in part to combine income and loss?
- Proposals indicate may be within “safe harbor”?

# Busted Section 351 Transaction to Make Section 338(h)(10) Election

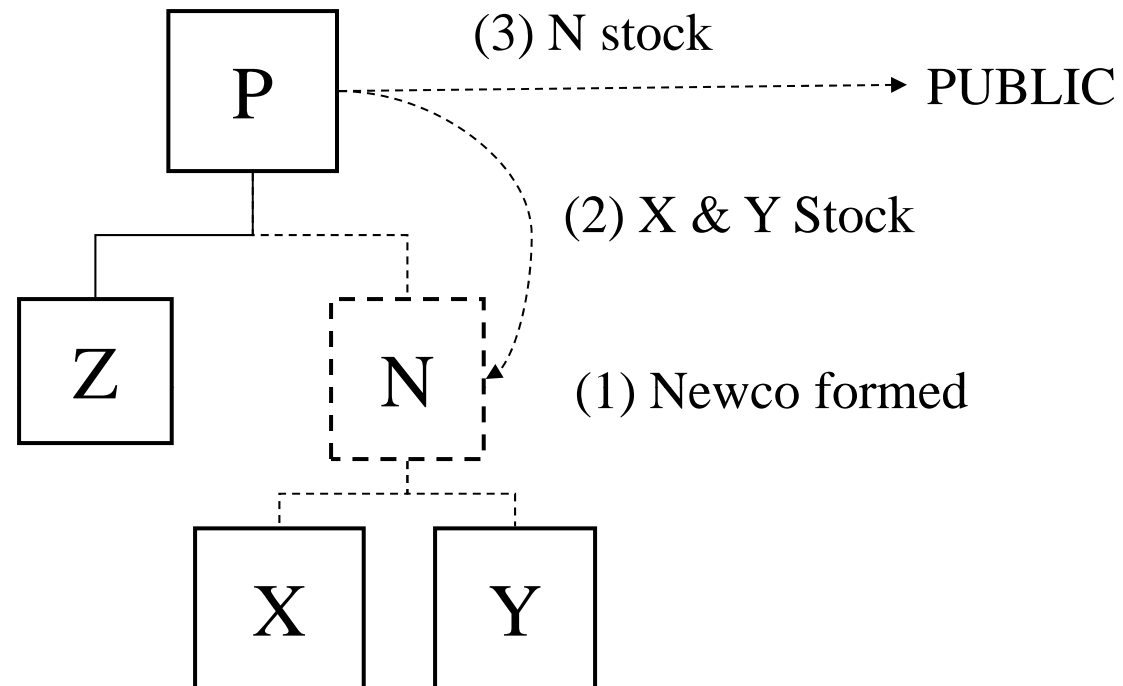

- A corporation transfers stock of a subsidiary to a newly formed subsidiary (“Newco”) for its stock and sells that stock to the public to “bust” the section 351 transaction and to be eligible to make the section 338(h)(10) election for Newco.
- Was there a business purpose or profit potential for the step of busting the 351?

# Section 197

## Section 197 Regulations

- On January 20, 2000, the Internal Revenue Service issued final regulations under section 197. 65 Fed. Reg. 3,820 (Jan. 25, 2000).
- Certain intangibles are excepted from section 197 if they are not acquired as part of the purchase of a trade or business. A trade or business is defined as it is in section 1060 (i.e., one to which goodwill or going concern value could, under any circumstances, attach).



## Section 197 Regulations Continued

- The regulations provide a few modifications to the anti-churning rules.
  - The regulations expressly state the purpose of the anti-churning rules and provide that the anti-churning rules are to be applied in a manner that carries out their purpose.
  - The regulations modify the definition of a related person for purposes of the anti-churning rules in the case of a series of related transactions. The regulations test relatedness only immediately before the first transaction and immediately after the last transaction, not during the period in between as in the proposed regulations. The regulations also apply this rule to a series of transactions that together comprise a qualified stock purchase within the meaning of section 338(d)(3).
  - The regulations also provide that any relationship created as part of a series of related transactions in which a person acquires stock of a corporation constituting 80 percent followed by a liquidation of the corporation under section 331 is generally disregarded.

## Section 197 Regulations Continued

- The regulations contain several rules relating to the application of the section 197 anti-churning rules in partnership situations.
  - The regulations distinguish between sale of an interest in an intangible asset followed by a contribution of the intangible to a partnership, on the one hand, and the formation of a partnership followed by the sale of the partnership interest on the other. The regulations provide that the anti-churning rules applied in the former situation but not the latter.
  - The regulations permit remedial allocations of amortization deductions to noncontributing partners, provided that they are not related to the contributing partner.
  - The continued use (by license or otherwise) of an intangible by a partner could cause the anti-churning rules to apply with respect to that partner's share of the intangible in situations where a basis step-up under section 732(d) or 743(b) otherwise would be amortizable.

## Section 197 -- Covenant Not to Compete Acquired in Connection with Stock Redemption

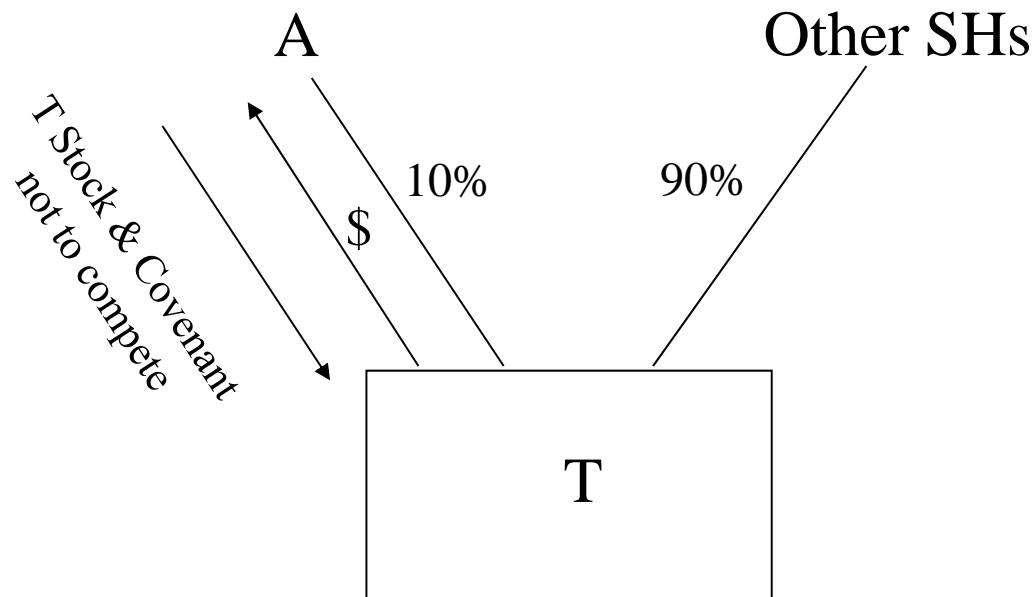

1. A owns 10 percent of T's stock.
2. T redeems all of its stock owned by A. T and A have no business relationship other than the corporation-shareholder relationship.
3. In connection with the stock redemption, T and A enter into a covenant not to compete, pursuant to which A agrees that he will not compete with the business of T within a prescribed geographical territory for a period of three years. T pays A consideration for this agreement in addition to the amount paid for the stock redeemed.

Does section 197 apply to the amount paid for the covenant not to compete?

## Section 197 -- Anti-Churning Rules

### Series of Transactions

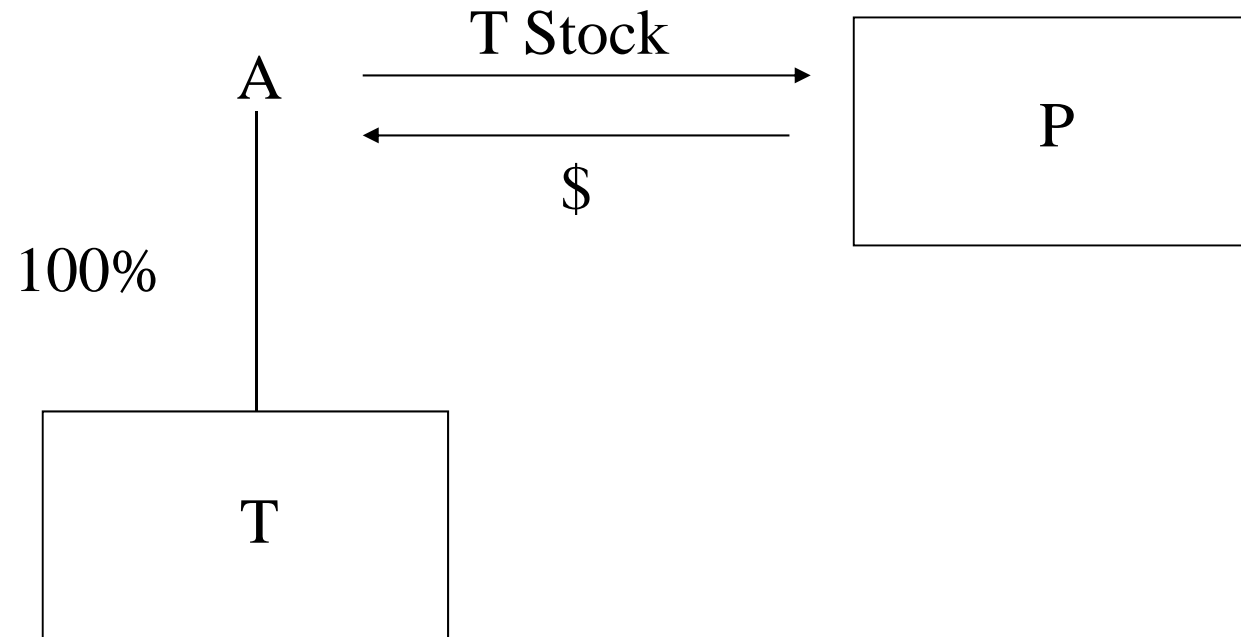

1. A owns all of T's stock.
2. P purchases 25 percent of the T stock from A in January of Year 1.
3. P purchases the remaining 75 percent of the T stock in June of Year 1 and makes a section 338 election.

Are P and T considered related for purposes of the anti-churning rules?

## Section 197 -- Anti-Churning Rules Series of Transactions

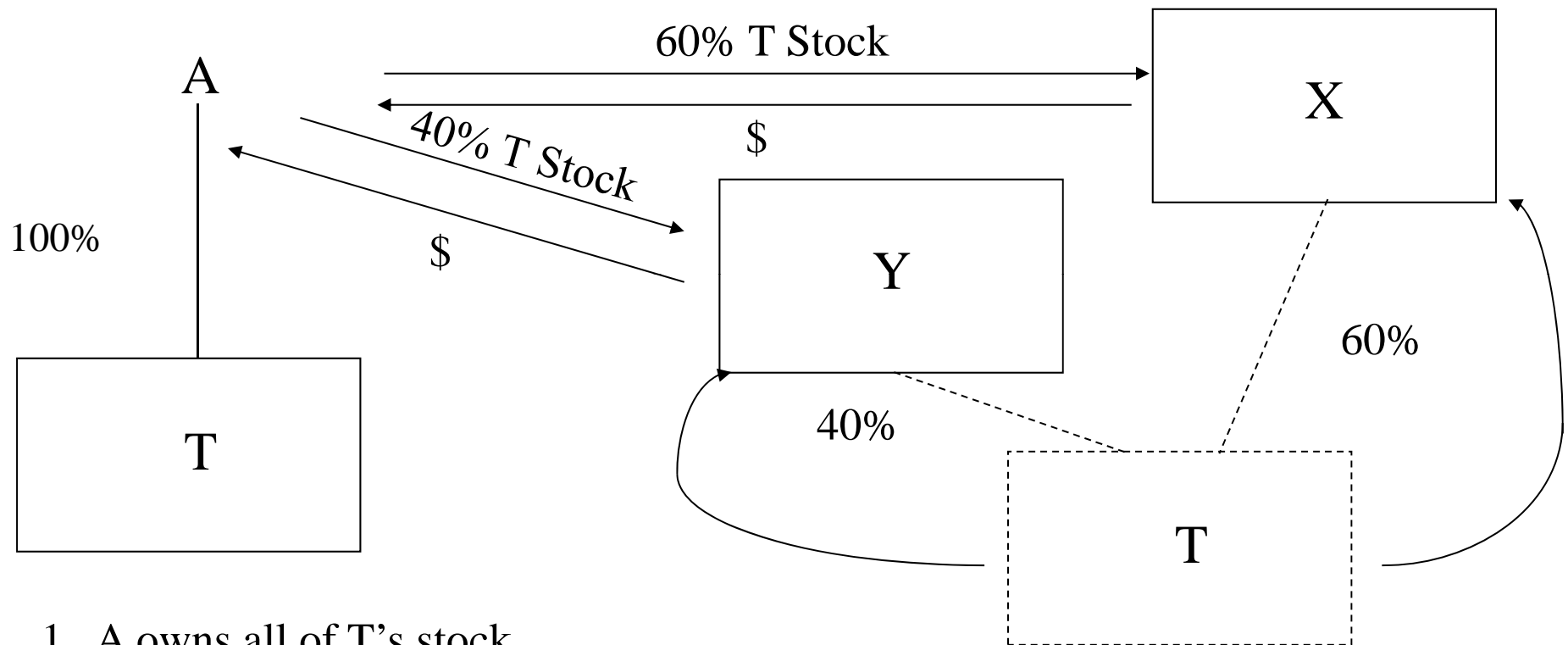

1. A owns all of T's stock.
2. A sells all of T's stock -- 60 percent to X and 40 percent to Y.
3. X and Y liquidate T under section 331.

Do the anti-churning rules apply to this transaction?

Section 197 -- Anti-Churning Rules  
Series of Transactions -- Partnership

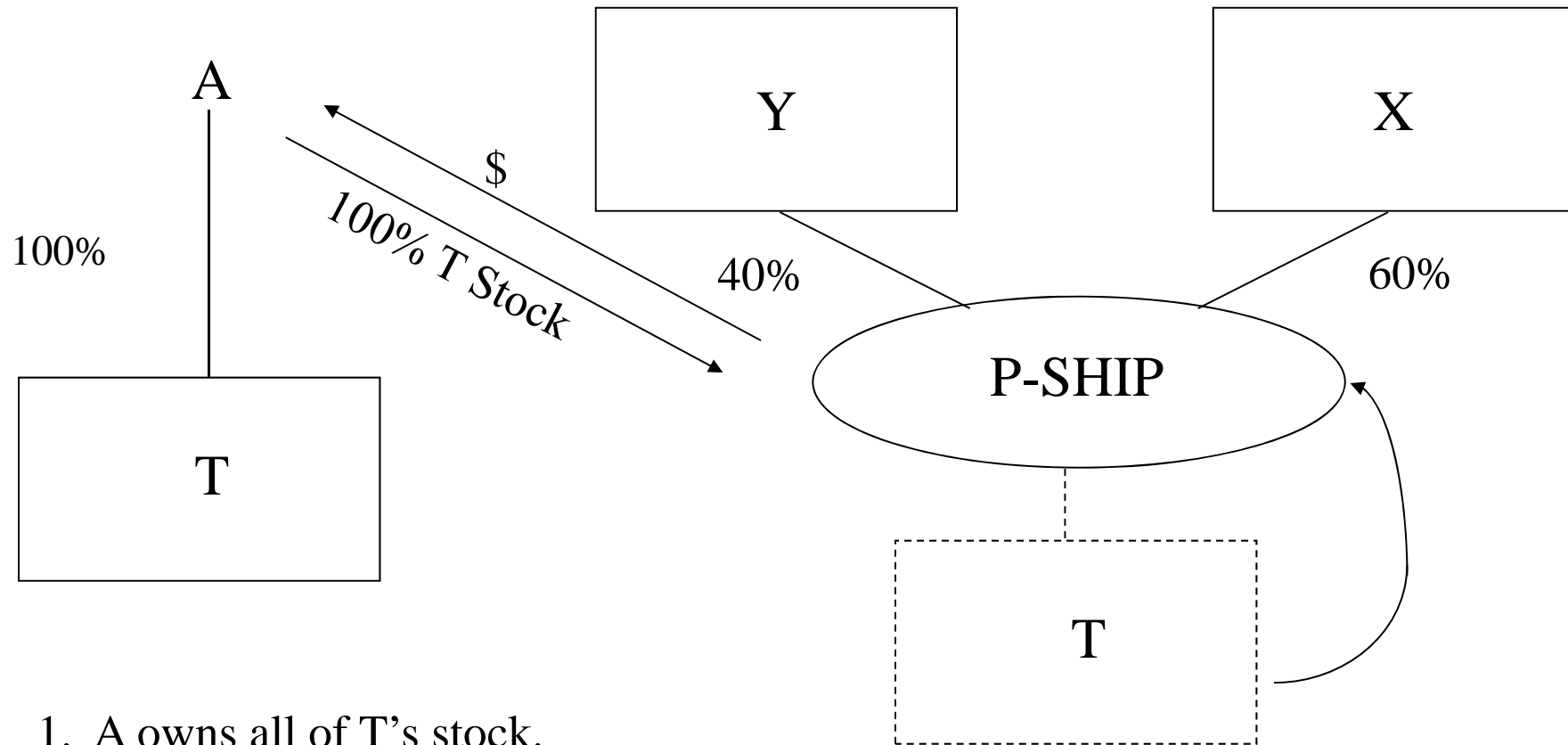

1. A owns all of T's stock.
2. A sells all of T's stock to P-SHIP, in which X has a 60-percent interest and Y has a 40-percent interest.
3. T liquidates into P-SHIP under section 331.

Do the anti-churning rules apply to this transaction?

## Section 197 -- Anti-Churning Rules Partnership

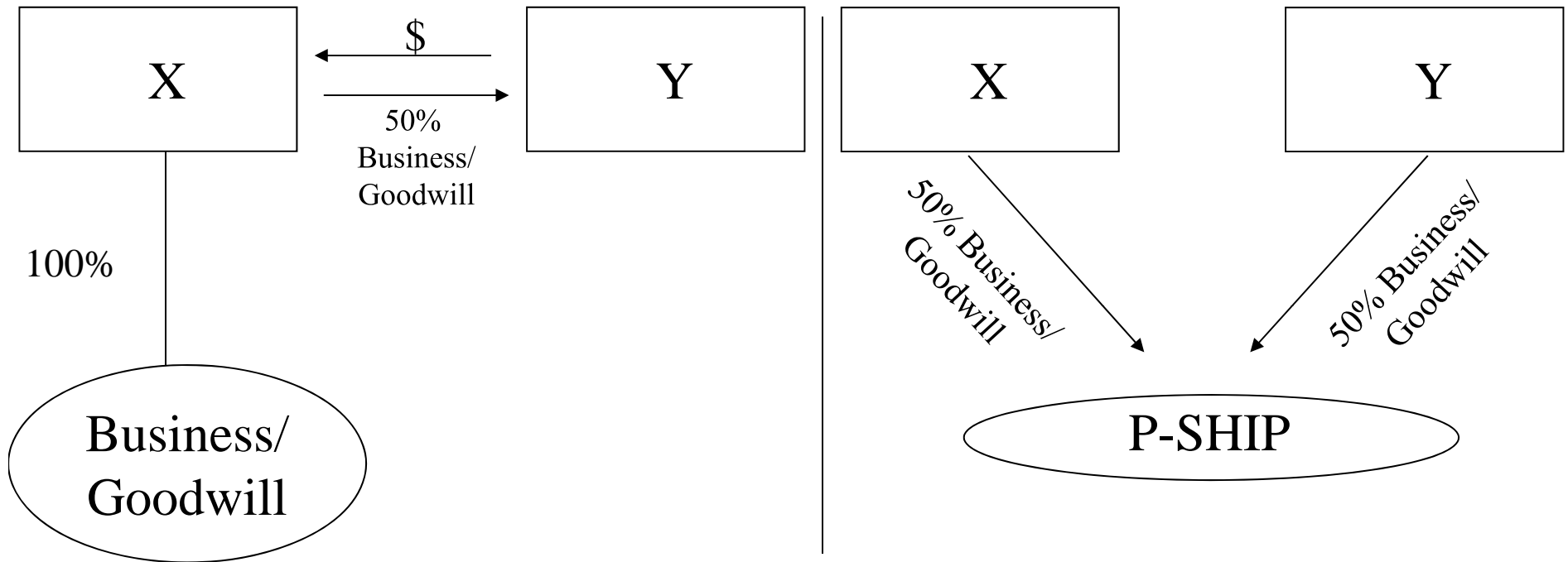

1. X owns a business (including goodwill), which it runs as a division.
2. X sells 50 percent of its business to Y.
3. X and Y contribute their respective interests in the business to a partnership.

Do the anti-churning rules apply to this transaction?

# Section 197 -- Anti-Churning Rules

## Partnership

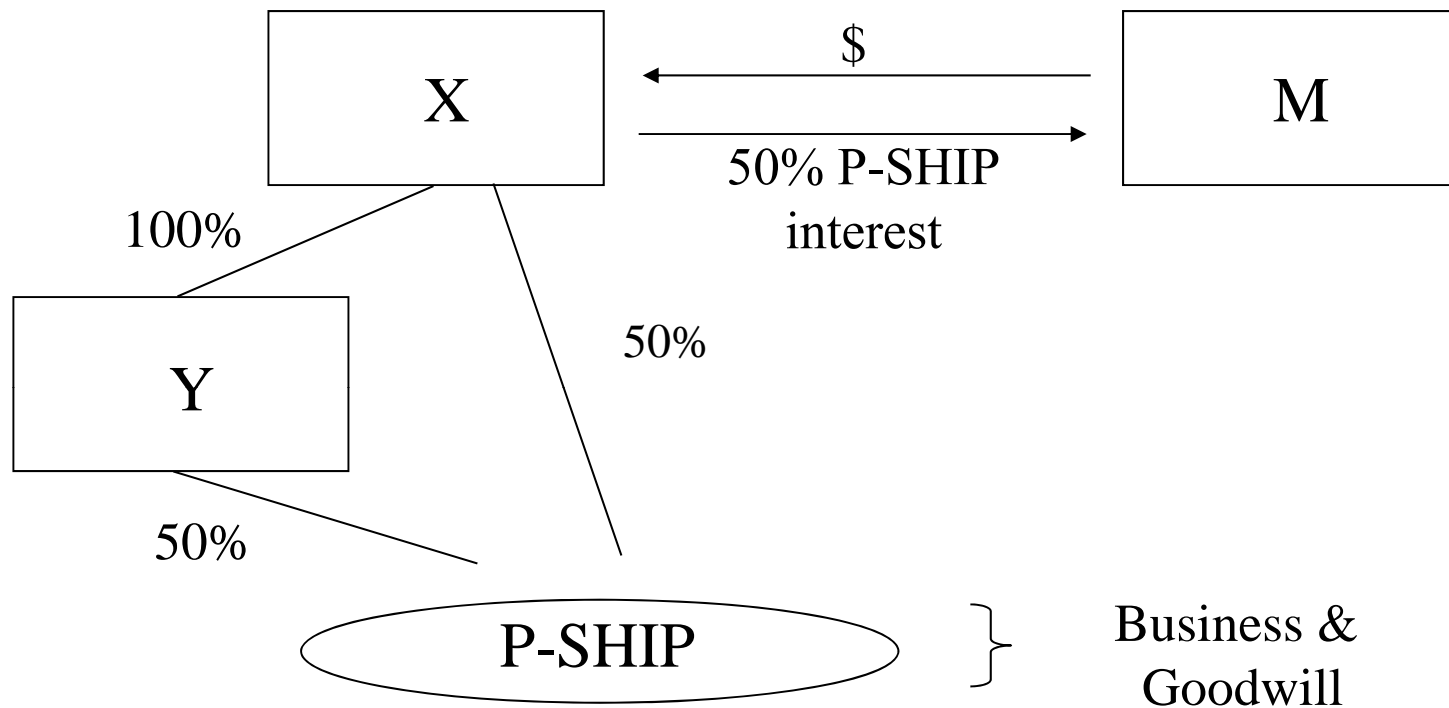

1. X and its wholly owned subsidiary, Y, own equal interests in a partnership. The partnership owns a business (including goodwill), and it has a section 754 election in place.
2. X sells its 50-percent partnership interest to M.

Do the anti-churning rules apply to this transaction?



## Section 197 -- Anti-Churning Rules

### Partnership

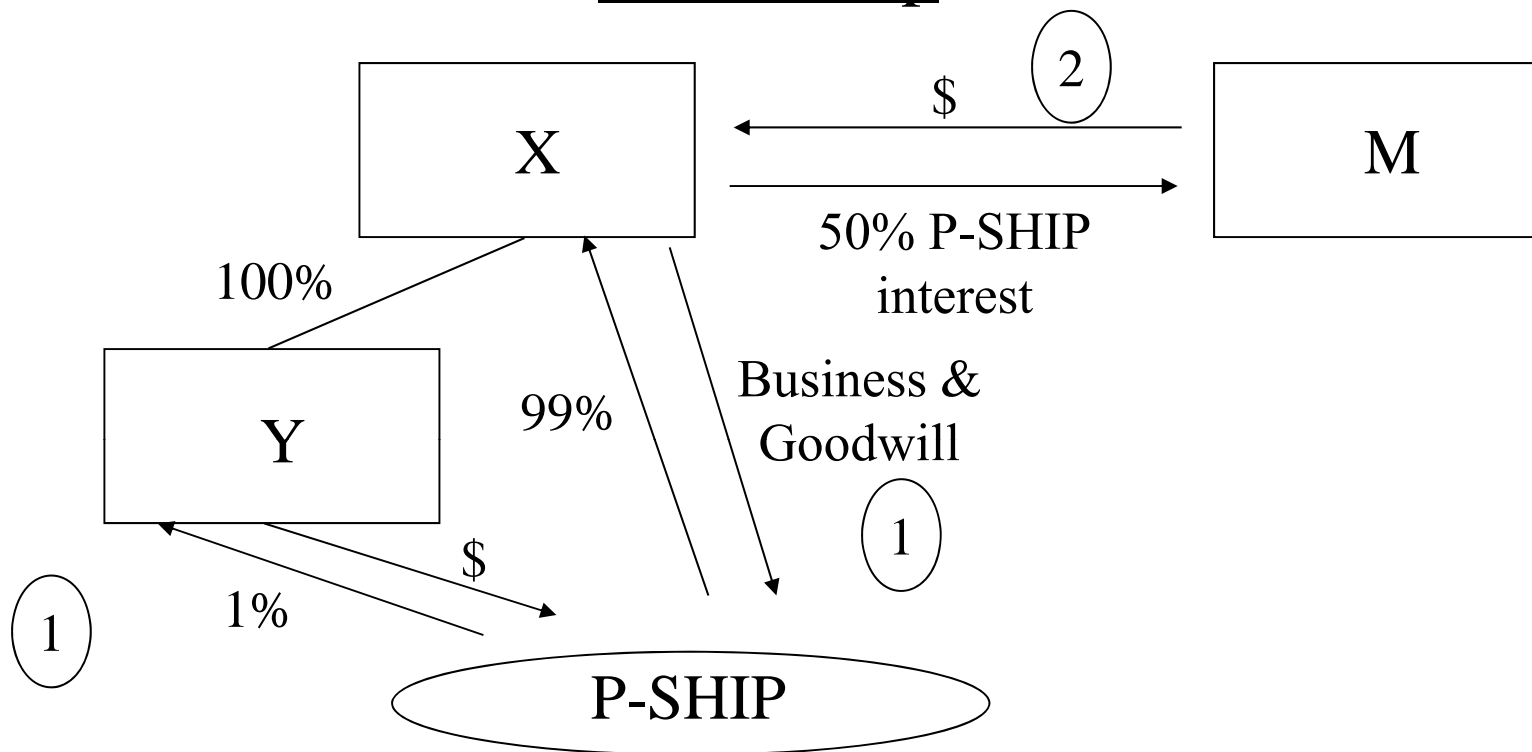

1. X and its wholly owned subsidiary, Y, form a partnership, with X contributing a business (including goodwill) in exchange for a 99-percent interest and Y contributing cash in exchange for a one-percent interest.
2. The partnership makes a section 754 election.
3. One month later, X sells a 50-percent partnership interest to M.

Do the anti-churning rules apply to this transaction?

## Section 197 Loss Disallowance Rules

- Loss Disallowance Rule 1: When several intangibles are acquired in the same transaction.
  - A loss from disposition or worthlessness of an intangible cannot be recognized if the taxpayer retains any other intangible *acquired in the same transaction or series of related transactions as the loss intangible*. Rather, the amount of the loss is added pro rata to the bases of the remaining intangibles. Section 197(f)(1)(A); Treas. Reg. § 1.197-2(g)(i).
- Loss Disallowance Rule 2: When a covenant not to compete (or similar arrangement) is acquired in the transaction.
  - A covenant not to compete is not considered disposed of or worthless until the “entire interest” acquired with the covenant is disposed of. The “entire interest” means all assets acquired – *both tangible and intangible*. Section 197(f)(1)(B); Treas. Reg. § 1.197-2(g)(iii).
  - Thus, in conjunction with Rule 1, until all the tangible and intangible assets acquired in a transaction or series of related transactions are disposed of or worthless, the covenant is considered retained and absorbs its proportionate share of unrecognized loss upon a disposition of another 197 asset. The covenant continues to be amortized for the 15 year recovery period.
  - When the last asset acquired in the transaction is disposed of or is worthless, the covenant may be treated as disposed of or worthless (assuming it is so) and its remaining basis can be deducted as a loss.

# Section 197 Loss Disallowance Rules: Example

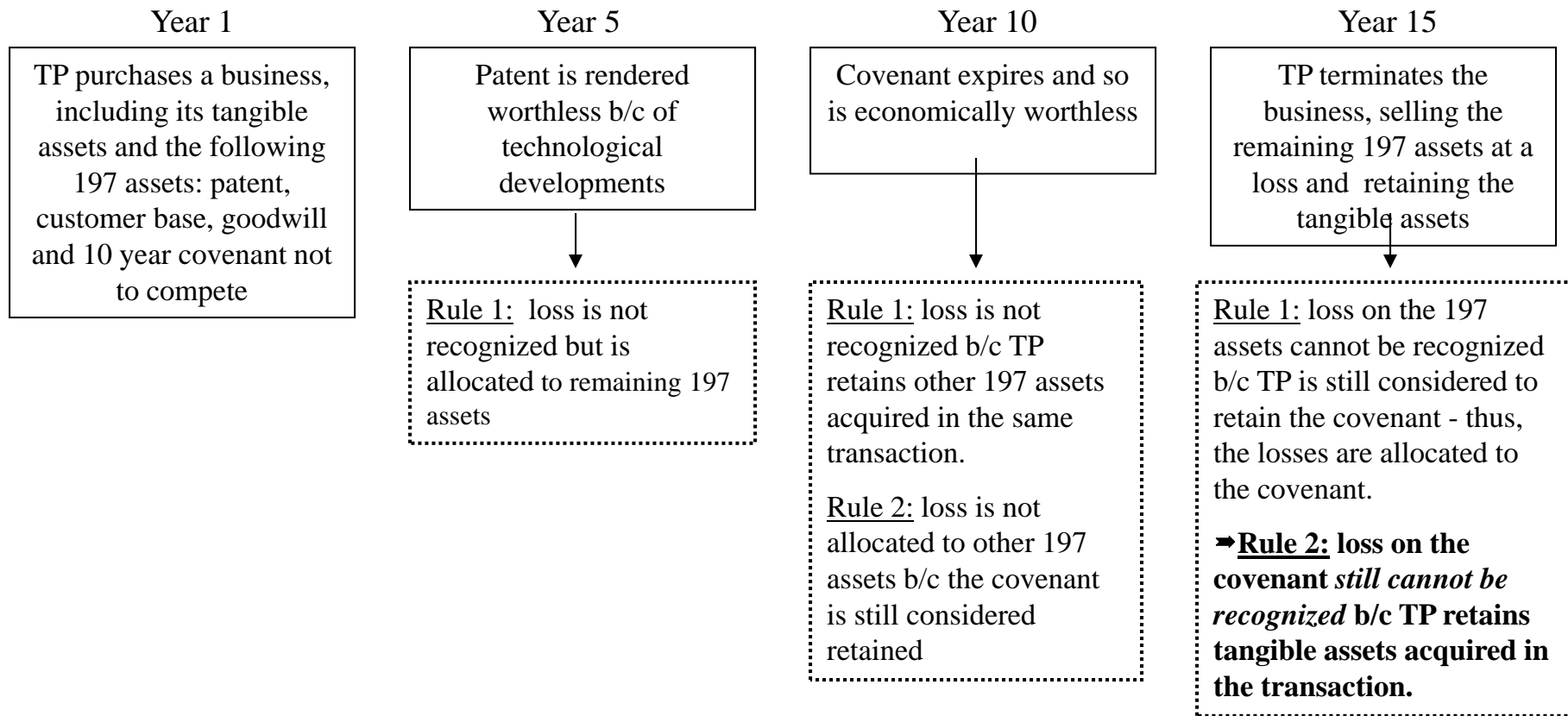

- Because a covenant not to compete was acquired in this transaction, the recognition of loss attributable to any of the 197 intangible assets is postponed until disposition or worthlessness of the tangible property acquired in the transaction.
- As soon as the last tangible asset acquired in the transaction is disposed of, the covenant can be treated as worthless and its remaining basis deducted as a loss.

## Proposed Regulations Under Section 336(e)

## Proposed Regulations Under Section 336(e)

- Section 336(e), adopted as part of *General Utilities* repeal in 1986, provides that, “under regulations prescribed by the Secretary,” a corporation (“Parent”) may treat a disposition of stock of a subsidiary (“Target”) as a disposition of the assets of Target (not a disposition of the Target stock), if –
  - Parent owns enough stock in Target to satisfy section 1504(a)(2), *i.e.*, 80% of total voting power and 80% of fair market value, and
  - Parent sells, exchanges or distributes all of such Target stock.
- This provision is viewed as an expression of section 338(h)(10) principles beyond situations in which
  - Parent sells 80% or more of the stock of Target to another corporation, or
  - S corporation shareholders sell more than 80% of their stock to a corporation.
- IRS has made clear its position that section 336(e) is not self-executing, *i.e.*, that no election can be made until regulations become effective. CCA 201009013 (March 5, 2010).
- On August 25, 2008, IRS and Treasury issued proposed regulations under section 336(e). 73 Fed. Reg. 49965.
- The proposed regulations would expand the scope of elective deemed asset sale treatment to cover any taxable “disposition” (a term with a meaning similar to “purchase” under section 338 but broader, to include distributions as well as sales) or series of dispositions by a domestic Parent (or its consolidated group) of stock of a domestic Target, if the total stock disposed of, to non-related persons within 12 months, satisfies section 1504(a)(2). Parent would not need to dispose of all of its Target stock.

## Proposed Regulations Under Section 336(e)

- Examples of covered transactions include:
  - Sale of Target stock to a partnership, individual or group of individuals, domestic or foreign.
  - Distribution of Target stock to shareholders to which section 355 does not apply, either a pro rata dividend or a non pro rata redemption.
  - Distribution of Target stock to which section 355 applies but is taxable to Parent under section 355(d) or section 355(e), either a pro rata dividend or a non pro rata redemption.
  - Combinations of the above within 12 months.
- Unlike the section 338(h)(10) election, the election to apply the section 336(e) regime is not joint but is unilateral to Parent. The Acquiror or Acquirors of the Target stock would have to require (or prevent) this election by agreement
- The election does not apply to sales or distributions of Target stock to persons related to Parent. A person is treated as related if stock owned by that person would be attributed to Parent under section 318(a) (other than the option rule in section 318(a)(4)), *i.e.*, generally a 50%-or-more overlap in ownership, directly, indirectly or through family relationships. Related party status is determined after the disposition: if there is a series of dispositions making up a “qualified disposition,” after the last disposition; or, if there is a series of transactions “effected pursuant to a plan to dispose of [T]arget stock,” after the last transaction. Prop. Reg. §1.336-1 (b)(4)(iii); Reg. §1.338-3(b)(3)(ii). Query: What is the scope of such a series of transactions?

## Proposed Regulations Under Section 336(e)

- The consequences of the related person rule include the following:
  - Section 336(e) cannot change an intercompany stock sale under section 304 into an all-cash type-D reorganization.
  - A taxable intra-group spin-off (either fully taxable or taxable to Parent alone under section 355(d) or section 355(e)) would not qualify for the election. As the preamble states, section 355(f) aggravates this situation by “turning off” section 355 for intra-group spinoffs that are followed by external spin-offs subject to section 355(e).
- IRS and Treasury have requested comments as to whether the section 336(e) election should be made available for related-party stock dispositions and, if so, how to prevent abuse (*e.g.*, use of loss carryovers, manipulation of earnings and profits and changes in accounting methods), and how to deal with section 355(f).
- The section 336(e) election would not be available if either Parent or Target is foreign. Some or all of the acquirors of the Target stock may be foreign persons. IRS and Treasury have requested comments on how the rules should be modified to take into account international tax policies if the election were made available in any of these situations.

## Proposed Regulations Under Section 336(e)

- If Parent makes a section 336(e) election in a stock sale, the construct is similar to that of a section 338(h)(10) stock sale. The following transactions are deemed to occur:
  - Target is deemed to sell all its assets to “New Target.”
  - Target’s amount realized is equal to the aggregate deemed asset disposition price (“ADADP”), allocated among the assets, as under sections 1060 and 338. ADADP is the sum of:
    - Amount realized on the sale of the Target stock (or, in the case of a distribution of Target stock, the fair market value of the distributed stock).
      - Grossed up to take into account the stock not disposed of.
    - Plus Target’s liabilities.
- New Target’s asset basis is determined by adjusted gross up basis of recently purchased stock (“AGUB”), as under section 338. But only non-recently purchased stock owned by 10% stockholders is used in the AGUB formula.
- Thereafter Target is deemed to transfer the consideration received in the deemed asset sale to Parent, generally in a section 332 liquidation.
- If the assets deemed sold include the stock of a subsidiary (“Sub”), the deemed sale of the Sub stock is eligible for a section 336(e) election (not a section 338(h)(10) election).
- Parent’s sales of Target stock are disregarded so long as they occurred during the 12 months ending on the day the election became available (the “disposition date”).<sup>199</sup>



## Proposed Regulations Under Section 336(e)

- If Parent retains any Target stock, Parent is treated as buying the stock so retained from New Target at fair market value on the disposition date. It appears that no gain or loss is recognized on this deemed transaction.
- A non-selling minority shareholder has no tax consequences, unless it makes a “gain recognition election” to recognize gain on the stock and obtain a stepped-up basis.
- A selling minority shareholder is treated like any other stock seller.
- An acquirer of Target stock is treated like any other stock buyer or distributee.
- If a minority shareholder buys Target stock, it has a mandatory gain recognition election. The result is the same as the result in a section 338(h)(10) sale of stock to a minority shareholder. Reg. §1.338(h)(10)-1(d)(1).
- If Parent makes a section 336(e) election for a taxable (non-section 355) stock distribution (pro rata or non-pro rata), the deemed transactions are similar to those in a sale, with twists:
  - Target is deemed to sell all its assets to New Target.
  - Gains are recognized, but losses are disallowed in proportion to the amount of stock distributed (vs. sold) to implement the policy of section 311(b).
  - Target is deemed to distribute the consideration deemed received for the assets to Parent (generally a section 332 liquidation).
  - Parent’s earnings and profits are adjusted to reflect gain or loss on the deemed asset sale and transfer by Target.

## Proposed Regulations Under Section 336(e)

- Parent is deemed to purchase from New Target the New Target stock that is distributed.
- No gain or loss is recognized to Parent in the stock distribution.
- The distributees take fair market value basis, as in any other taxable distribution.
- If Parent distributes Target stock in a distribution subject to section 355(d) or section 355(e), the section 336(e) election is available. If the election is made, the deemed transactions are as follows:
  - Target is deemed to sell all its assets to an unrelated person and then re-acquire the assets (“sale-to-self” treatment).
    - Target’s amount realized on the deemed sale is determined under ADADP principles.
    - Target’s basis in the assets deemed sold and re-acquired is determined under AGUB principles.
  - In a spinoff under section 355(d) or section 355(e), the distributee shareholders do not take a cost basis in the stock, and the AGUB formula would produce a mismatch between amount realized and basis in the deemed asset sale.

## Proposed Regulations Under Section 336(e)

- There is no deemed liquidation of Target or any other deemed transfer of asset sale consideration.
- Parent's distribution of the Target stock is given effect.
- Thus, Target's tax attributes remain intact. Target's earnings and profits are adjusted to reflect gain or loss on the deemed asset sale.
- Target's gains in the deemed asset sale are recognized in full, but Target's losses are disallowed in proportion to the amount of stock distributed.
- If Target's assets include stock of Sub, that stock is deemed sold. The section 336(e) election is available for that transaction. The deemed transactions are those for a stock sale.

## Requirements for Section 336(e) Election

- Seller is a domestic corporation.
- Qualified stock disposition.
  - One or more dispositions of stock if the stock disposed of, in total, meets the requirements of section 1504(a)(2) (80% vote and value).
  - Taxable sale, exchange or distribution.
  - During 12-month disposition period.
- Not a qualified stock purchase under section 338(d)(3).
- Election filed under Prop. Reg. § 1.336-2(h).

## Section 336(e) vs. Section 338(h)(10)

- The proposed regulations rely on the structure and principles of section 338(h)(10) when they are consistent with the purposes of section 336(e). Prop. Reg. § 1.336-1(a).
- Unlike the section 338(h)(10) election, the election to apply the section 336(e) regime is not joint but is unilateral to the seller. However, the election affects both the seller and Target (and therefore the acquiror of the Target stock). Thus, the acquiror would have to require or prevent this election by agreement.

# Section 336(e) vs. Section 338(h)(10)

## Modifications to terms in Reg. §1.338-5

<b><u>338</u></b>	<b><u>336(e)</u></b>
<ul style="list-style-type: none"><li>■ Section 338 or 338(h)(10) election</li><li>■ Purchasing corporation</li><li>■ Selling consolidated group/affiliate</li><li>■ Qualified stock purchase</li><li>■ Acquisition date</li><li>■ 12-month acquisition period</li><li>■ Recently/nonrecently purchased stock</li><li>■ Aggregate deemed sales price (ADSP)</li></ul>	<ul style="list-style-type: none"><li>■ Section 336(e) election</li><li>■ Purchaser</li><li>■ Seller</li><li>■ Qualified stock disposition</li><li>■ Disposition date</li><li>■ 12-month disposition period</li><li>■ Recently/nonrecently disposed stock</li><li>■ Aggregate deemed asset disposition price (ADADP)</li></ul>

## Proposed Section 336(e) Regulations – Tax Consequences

- Sale of assets by Old T to New T at aggregate deemed asset disposition price (ADADP) =
  - Amount realized on sale or exchange of target stock (or deemed amount realized on distribution of target stock), grossed up to take into account disposition of less than all of the target stock
    - Selling costs
    - + Liabilities of Old Target
    - Gains are recognized, but losses are disallowed in proportion to the amount of stock distributed (vs. sold) to implement the policy of section 311(b).
    - If the assets deemed sold include the stock of a subsidiary (“Sub”), the deemed sale of the Sub stock is eligible for a section 336(e) election (not a section 338(h)(10) election).
- New T’s asset basis is adjusted grossed-up basis (AGUB).
- Deemed liquidation of Old Target generally treated as section 332 liquidation.

## Proposed Section 336(e) Regulations – Tax Consequences to Minority Shareholders

- A non-selling minority shareholder has no tax consequences, unless it makes a “gain recognition election” to recognize gain on the stock and obtain a stepped-up basis in the stock retained.
- A selling minority shareholder is treated like any other stock seller.
- An acquirer of target stock is treated like any other stock buyer or distributee.
- If a minority shareholder buys target stock, it has a mandatory gain recognition election. The result is the same as the result in a section 338(h)(10) sale of stock to a minority shareholder. Reg. §1.338(h)(10)-1(d)(1).



## Qualified Stock Purchase

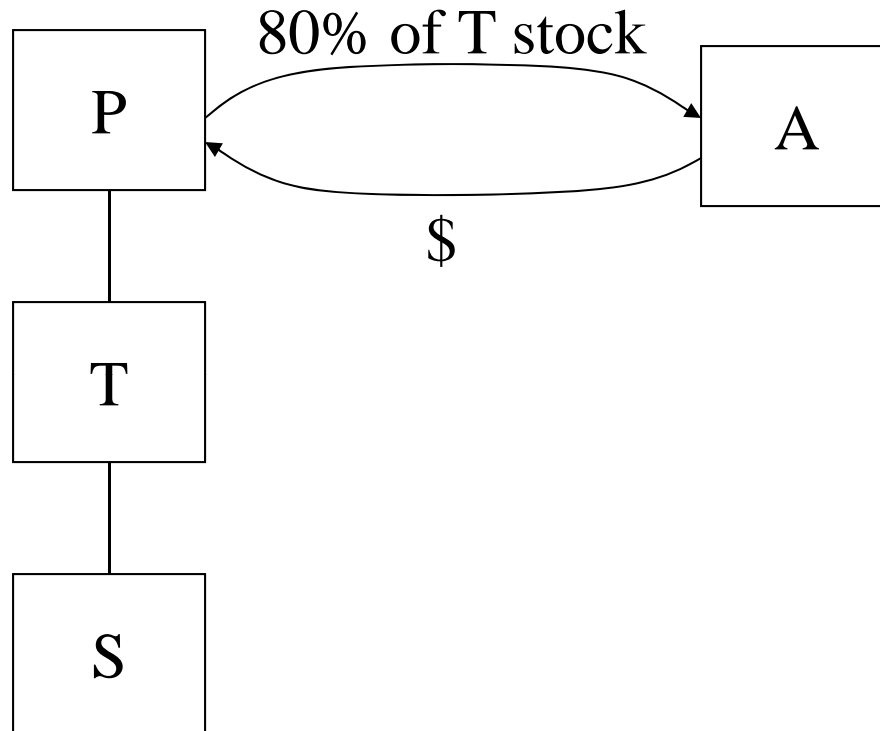

- P sells all the T stock to A for cash.
  - Joint section 338(h)(10) election available at T and S levels.
  - Because the joint section 338(h)(10) election is available, no election would be available under section 336(e). Prop. Reg. §1.336-1(b)(5)(ii)(A).

# Qualified Stock Disposition – Sale – General

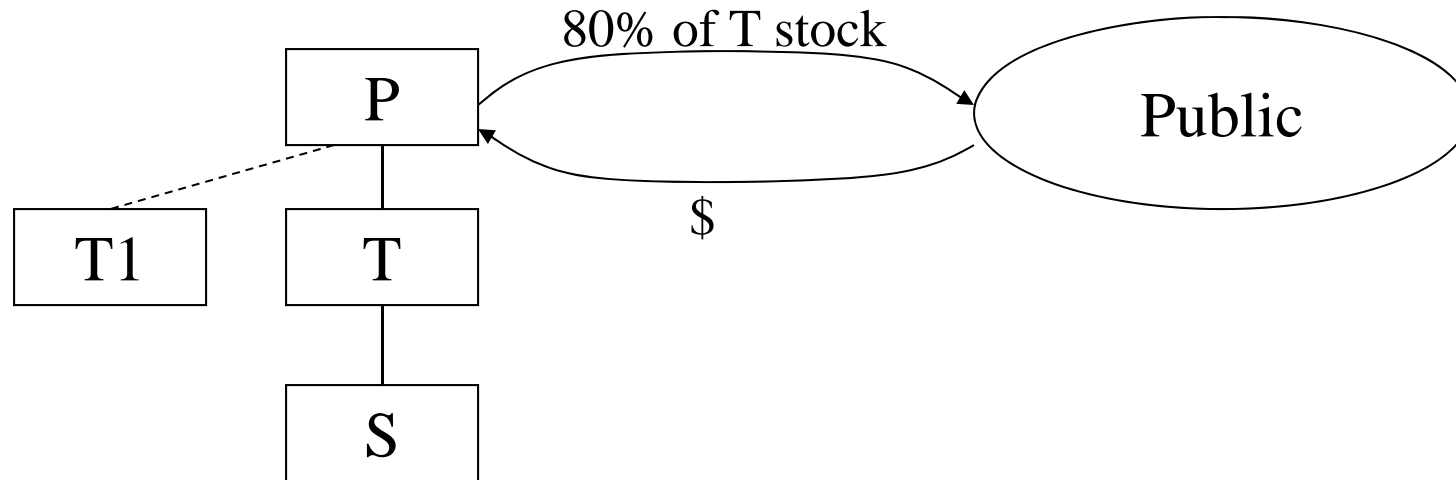

- If P sells its T stock directly to Public, there is no corporate purchaser and so no qualified stock purchase. Thus, no joint section 338(h)(10) election is available.
- Reg. §1.338-3(b)(3)(iv) *Example (1)* provides a way to accomplish this transaction, by P transferring the T stock to T1 in a taxable “busted B/busted 351” transfer and selling the T1 stock to the Public. These transactions, however, are complex and have pitfalls.
- Under Prop. Reg. §1.336-2(a), P would be able to elect to treat a sale of the T stock directly to Public as a sale of T assets to “New T” and a generally tax-free liquidation of T. P would make this election unilaterally.
- P would need to determine if more than 20% of the T stock is sold to related persons. If so, no section 336(e) election would be available.
- Since the T assets include the S stock, that stock would be deemed sold to New T. This deemed sale is subject to a section 336(e) election, not a section 338(h)(10) election. Prop. Reg. §1.336-1(b)(5)(ii)(B).

## Stock Sale with Section 336(e) Election

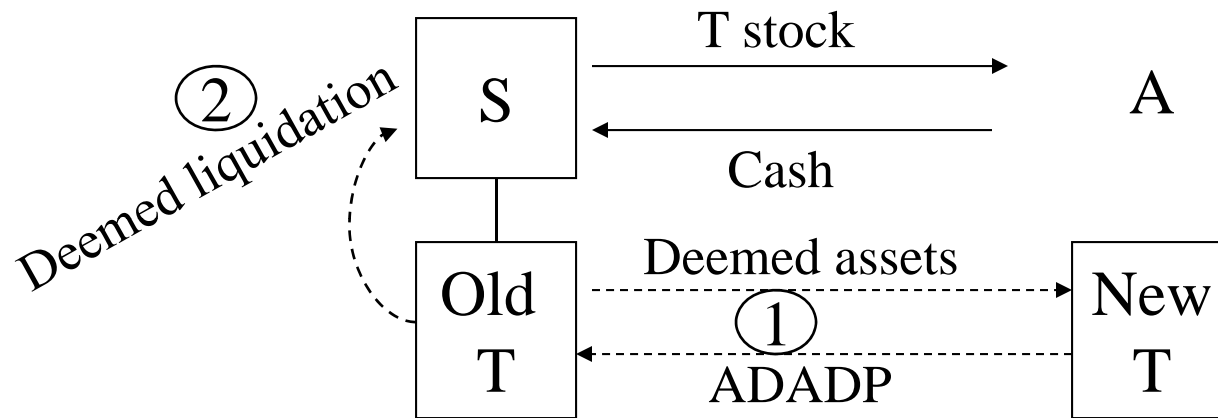

- S disregards the sale of Old T stock.
- Instead Old T is deemed to sell its assets to New T and liquidate into S.
- New T has no tax attributes.
- A is still treated as purchasing Old T stock.

## Qualified Stock Disposition – Sale – Timing

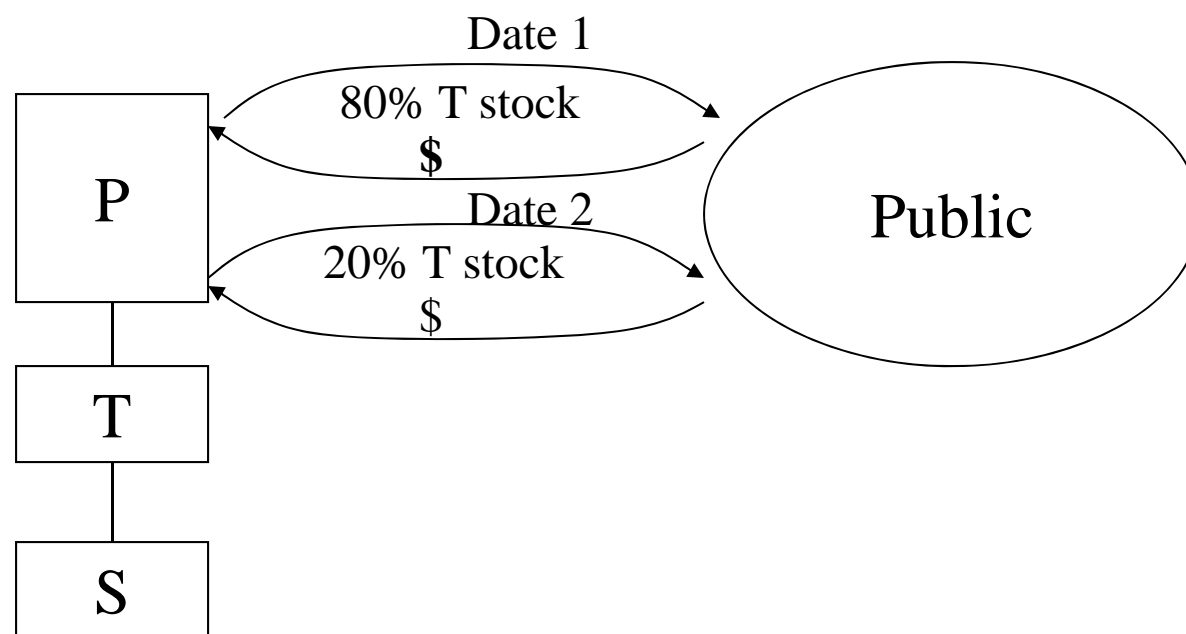

- P sells 80% of the T stock to the Public on Date 1 and the remaining 20% to the Public on Date 2 (less than 12 months after Date 1).
- If P makes a section 336(e) election, T would be deemed to sell all its assets (including the S stock) to New T. T would recognize its gains and losses on asset sale.
- P's Date 1 sale of T stock would be disregarded.
- P's Date 2 sale of T stock would be a taxable sale, but P's gain or loss would be the appreciation or depreciation in the T stock between Date 1 and Date 2.

Prop. Reg. §1.336-2(b)(2)(iv).

# Qualified Stock Disposition – Sale – Asset Basis

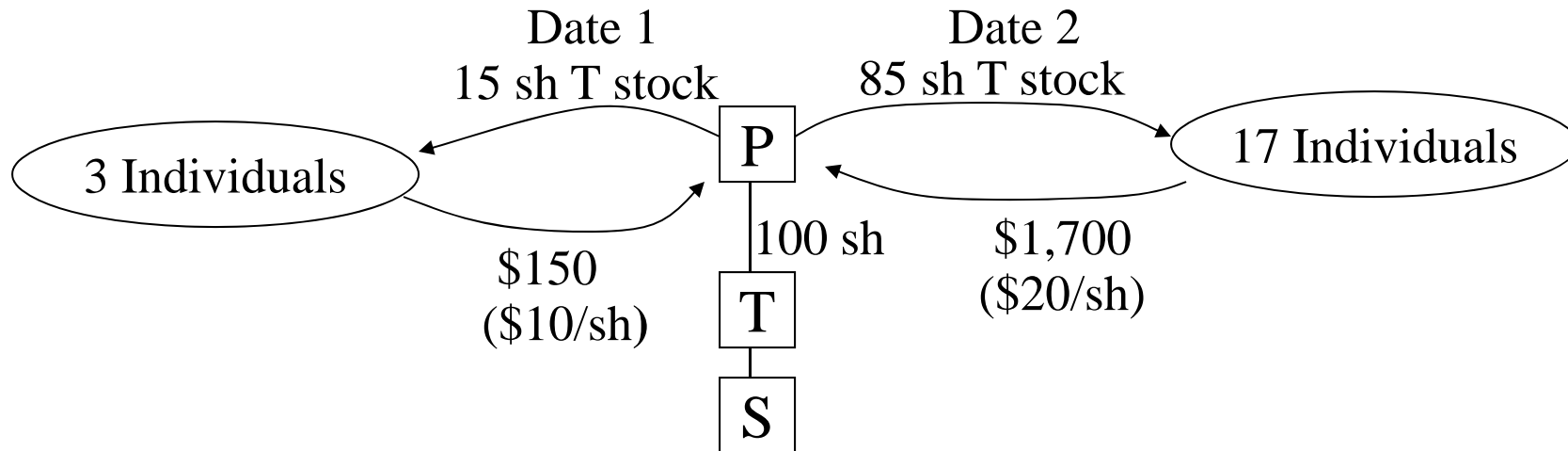

- On Date 1, P sells 15 shares of T stock to 3 unrelated individuals, 5 shares each, for a total of \$150 (\$10/share).
- On Date 2 (more than 12 months after Date 1) P sells the remaining 85 shares of T stock to 17 unrelated individuals, 5 shares each, for a total of \$1,700 (\$20/share).
- If P makes a unilateral section 336(e) election, T is deemed to sell all its assets to “New T” and liquidate. T recognizes all its gains and losses on this sale.
- Among the assets deemed sold is the stock of S. This transaction is also eligible for a section 336(e) election.
- T’s amount realized on the deemed asset sale is based on ADADP principles – here equal to the sale price for the stock plus T’s liabilities.
- T’s basis for its deemed purchased assets is based on AGUB principles, but the only non-recently purchased stock that counts is stock owned by more-than-10% shareholders (none here).
- Variation: The 3 individuals who buy T stock on Date 1 pay \$300 (\$30/share) and form a partnership to buy the T stock immediately before Date 1.

# Taxable Stock Distribution with Section 336(e) Election

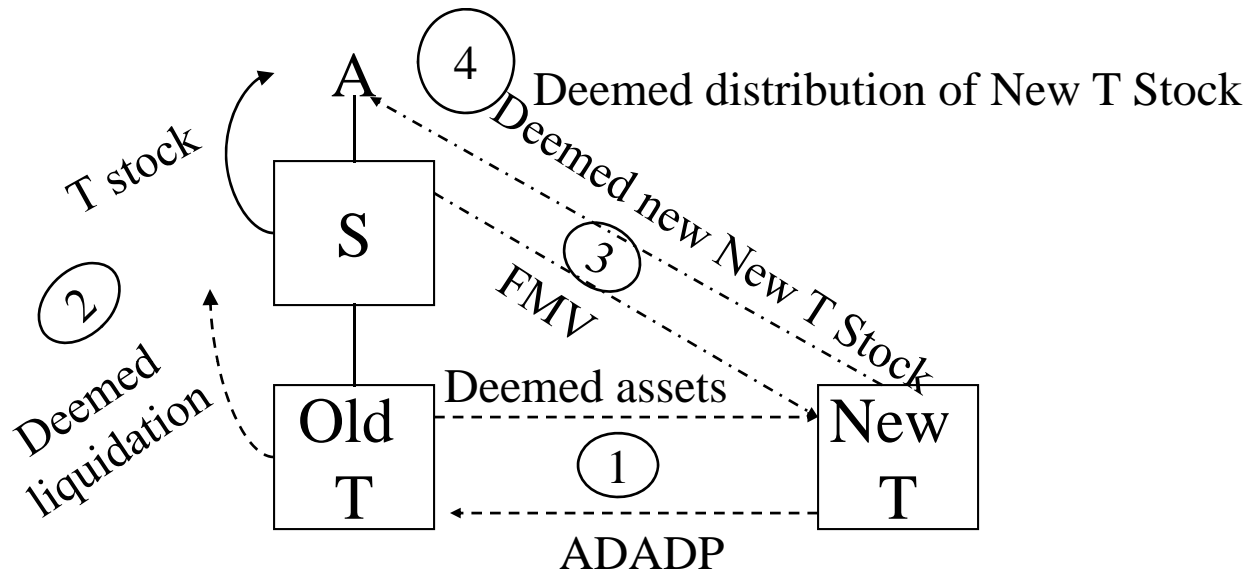

- S disregards distribution of Old T stock.
- Instead Old T is deemed to sell its assets to New T and liquidate into S. Old T recognizes gain but losses are disallowed in proportion to the amount of stock distributed.
- S is deemed to purchase an amount of New T stock distributed to A in the qualified stock disposition and distribute that stock to A.
- New T has no tax attributes.
- A is treated as receiving Old T stock in the distribution with a fair market value basis.<sup>213</sup>

# Qualified Stock Disposition – Non-Section 355 Intra Group and Non Pro Rata External Distributions

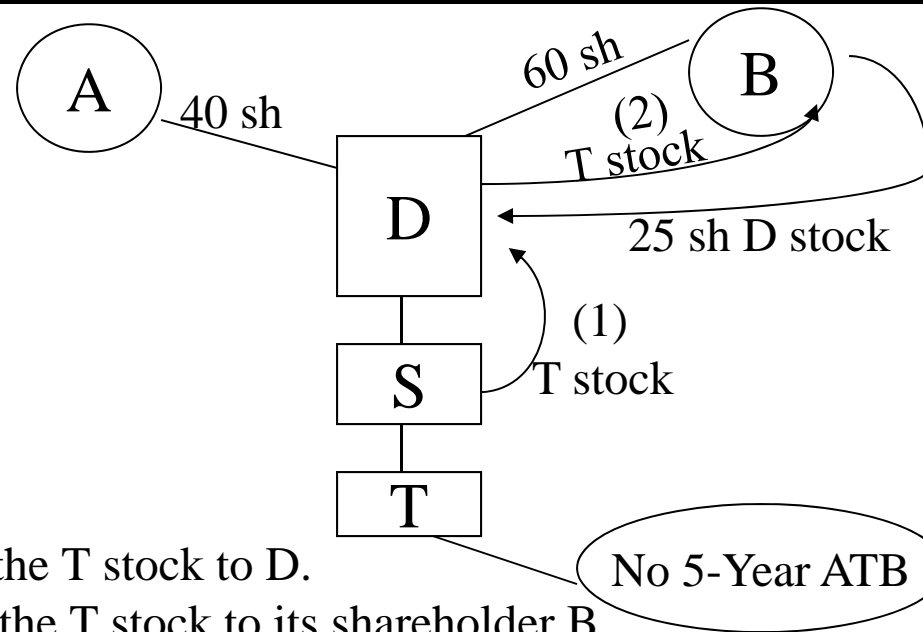

- S distributes the T stock to D.
- D distributes the T stock to its shareholder B.
- T has no 5-year active trade or business, and so both distributions flunk section 355 and are taxable.
- The first distribution is not eligible for a section 336(e) election, because S and D are related. Prop. Reg. §1.336-12(k) *Example (9)*.
- The second distribution is eligible for a section 336(e) election, because thereafter D and B are not related persons. Prop. Reg. §1.336-1-2(k) *Example (8)*. In the deemed asset sale, T recognizes its gains, but its losses are disallowed. Prop. Reg. §1.336-2(b)(1)(i)(B).
- Variation: In the second distribution, D distributes the T stock to A and B pro rata. The second distribution would not qualify for a section 336(e) election, because B and D are related persons. Only the distribution to A is a “disposition” of T stock, and it involves less than 80% of the T stock.

## Qualified Stock Disposition – Spin-Off Subject to Section 355(d) or (e)

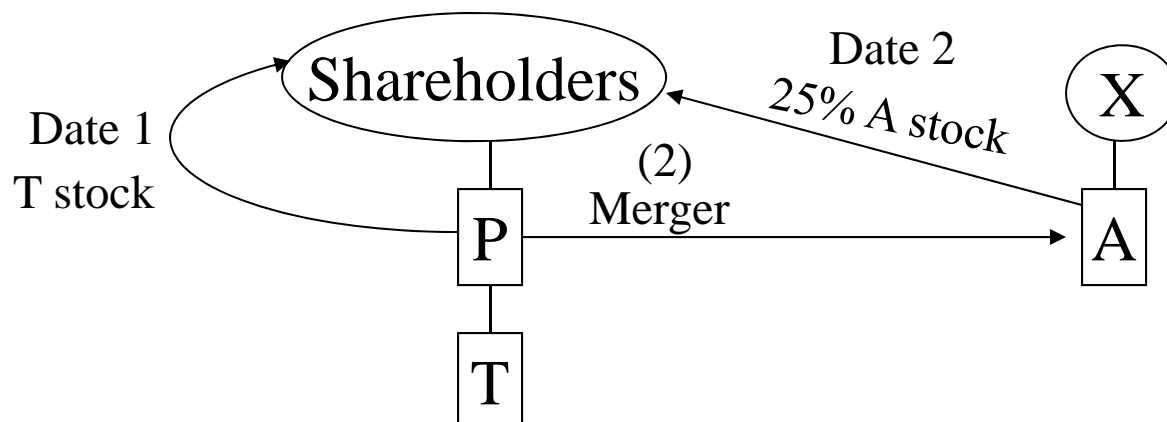

- On Date 1, P distributes the T stock to Shareholders, pro rata, in a spin-off qualifying under section 355.
- On Date 2, as part of the same “plan,” P is merged into A. Shareholders receive 25% of the A stock.
- Shareholders receive the T stock tax-free under section 355 and then the A stock tax-free under section 354(a). Their basis in their P stock is allocated between their P stock and their T stock, and their basis in their A stock is the same as their basis in their P stock after the T spin-off.
- Under section 355(e), T recognizes its gain on the distribution of the T stock. Thus T would be eligible to make a section 336(e) election, if more than 80% of the stock was distributed to non-related persons. Suppose a “related” P shareholder becomes not “related” as a result of the merger?
- If P makes the election, T is deemed to sell its assets and repurchase them. No liquidation.
- T recognizes its gains, but its losses are disallowed.
- T’s basis in the assets is determined by AGUB. Prop. Reg. §1.336-2(b)(2)(ii)(A). Note that Shareholders’ basis in their T stock is not fair market value.
- Variation: P sells 20% of the T stock and distributes 80% of the T stock at the same time.



## Section 355(d) or (e) Stock Distribution with Section 336(e) Election

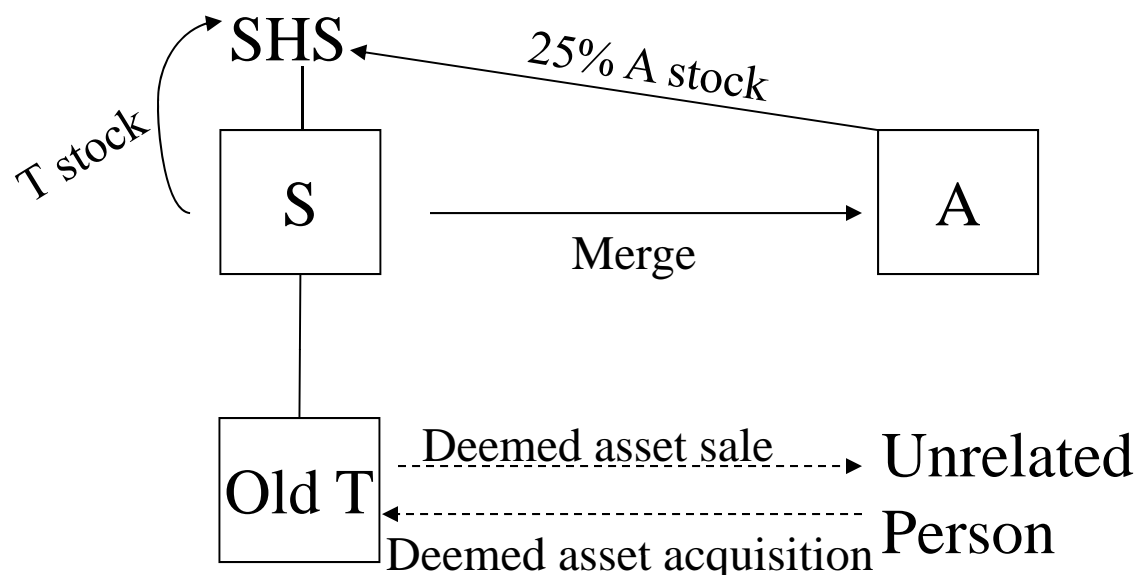

- The controlled corporation, Old T, is deemed to sell its assets to an unrelated person and reacquire those assets (sale-to-self treatment).
- Then the distributing corporation, S, is treated as distributing the stock of Old T to its shareholders in the spin-off. Old T recognizes gain but losses are disallowed in proportion to the amount of stock distributed. The shareholders determine their basis under section 358.
- Old T retains its tax attributes.
- The deemed sale and reacquisition will not cause the transaction to fail to satisfy the requirements of section 355.

## Deemed Treatment as a Result of a Section 336(e) Election

	<b>Sales and Exchanges</b>	<b>Taxable Spins</b>	<b>Section 355(d) and (e) Spins</b>
<b>Deemed Asset Sale by Target</b>	<b>Yes</b>	<b>Yes</b>	<b>Yes</b>
<b>Losses Recognized</b>	<b>Yes</b>	<b>No</b>	<b>No</b>
<b>Deemed Liquidation of Target</b>	<b>Yes</b>	<b>Yes</b>	<b>No</b>

## Loss Disallowance — Facts

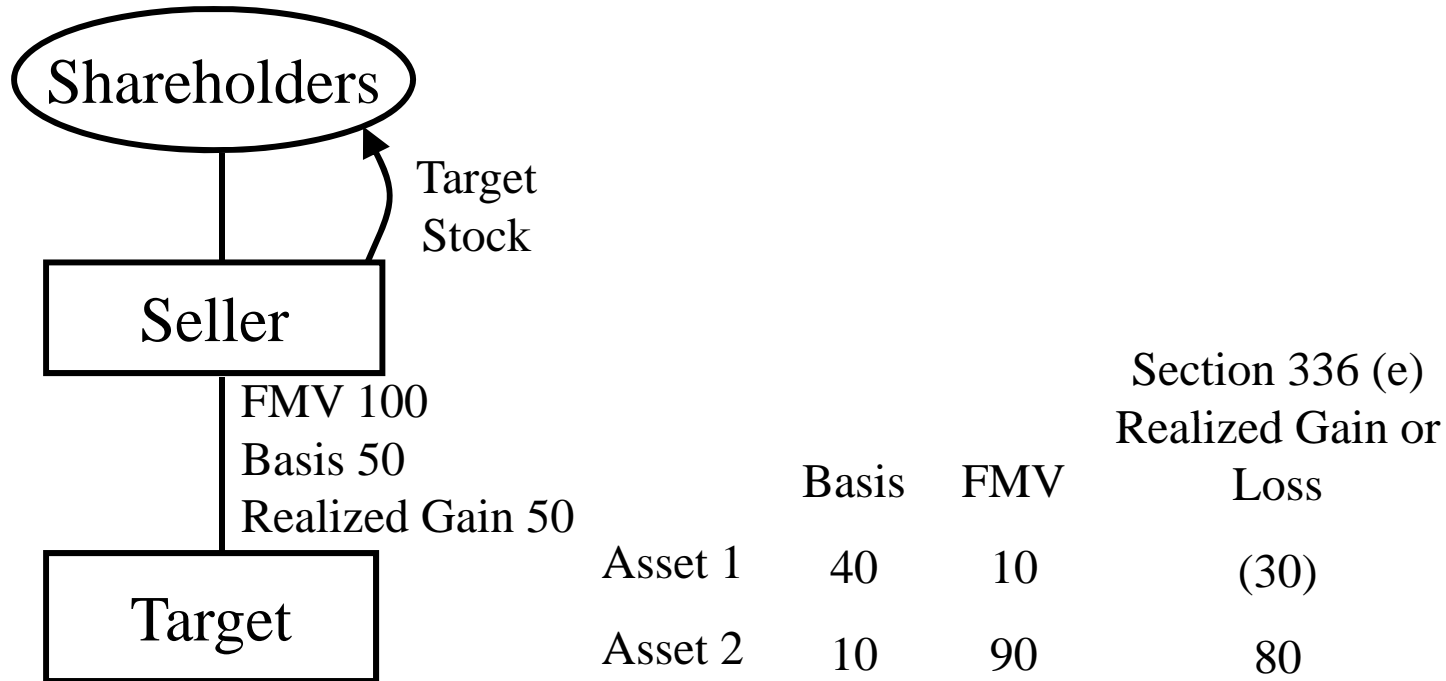

- On Date 1, Seller forms Target and contributes Asset 1 and Asset 2 to Target. Asset 1 has a basis and fair market value of 40, Asset 2 has a basis and fair market value of 10. Seller takes a 50 basis in the stock of Target, which is worth 50. On Date 2, when Asset 1 is worth 10 and Asset 2 is worth 90, Seller distributes all the Target stock to Seller shareholders in a transaction to which a section 336(e) election applies. At the time of the distribution, the stock of Target is worth 100.

## Loss Disallowance — Results

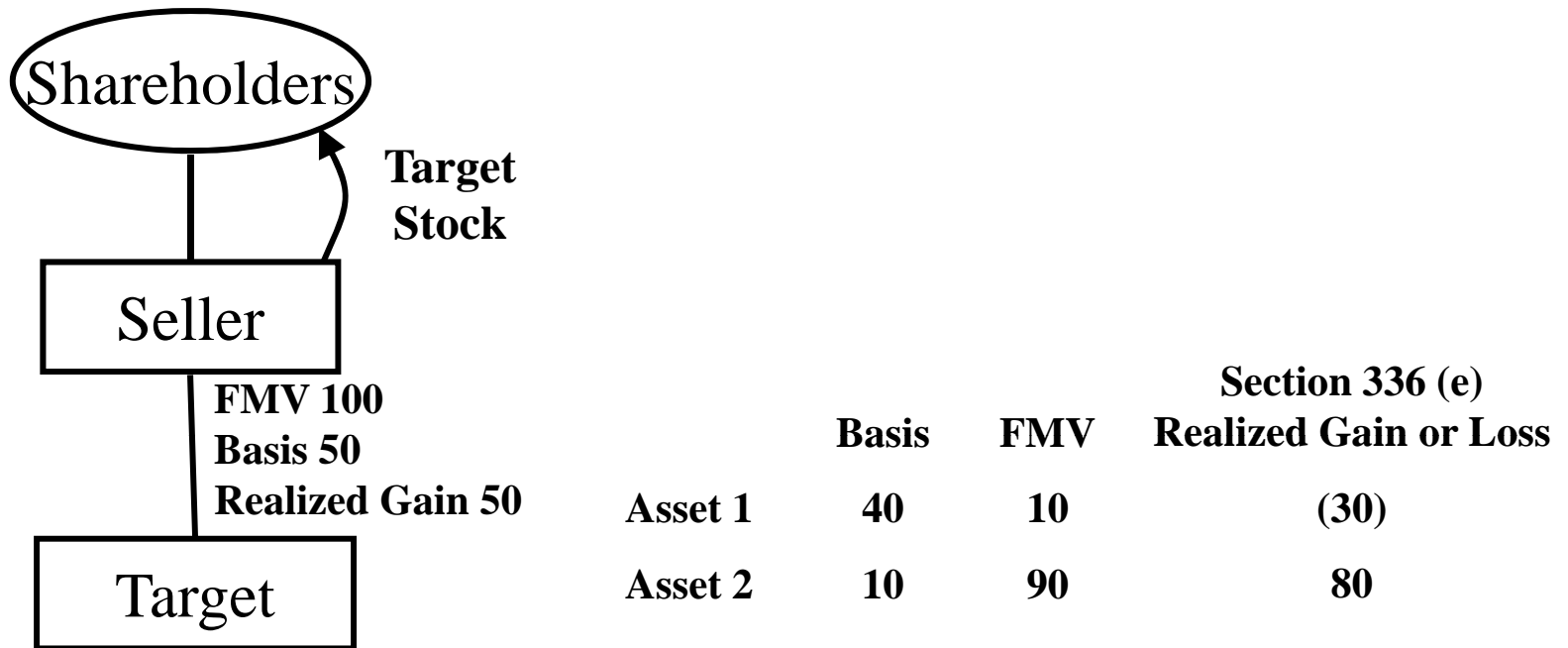

- If no section 336(e) election is made, 50 of gain under section 311(b).
- Under proposed section 336(e) regulations, 80 of gain. 30 loss is disallowed.
- Under a “netting” approach, the 30 loss would be allowed to be used up to the amount of the gain. Thus, all 30 would be allowed for an overall gain of 50 (equal to 80 of gain on Asset 2 less 30 of loss on Asset 1).
- Under a “gross loss” approach, all loss would be recognized regardless of the amount of gain. Here, same result as under netting approach.

## Section 351 Transactions

- Following section 338 and a reference in the legislative history to permitting section 336(e) elections in the case of “taxable” transactions, the proposed regulations require that, in order to make a section 336(e) election, the Target stock may not, in general, be “sold, exchanged, or distributed in a transaction to which section 351, 354, 355, or 356 applies.” Prop. Reg. § 1.336-1(b)(4)(i)(B).
- However, unlike section 338, the statute does not impose this “purchase” requirement for section 336(e) elections. Thus, the IRS could expand the regulations to permit a section 336(e) election in the case of a disposition covered by section 351.

## Section 351 Transactions

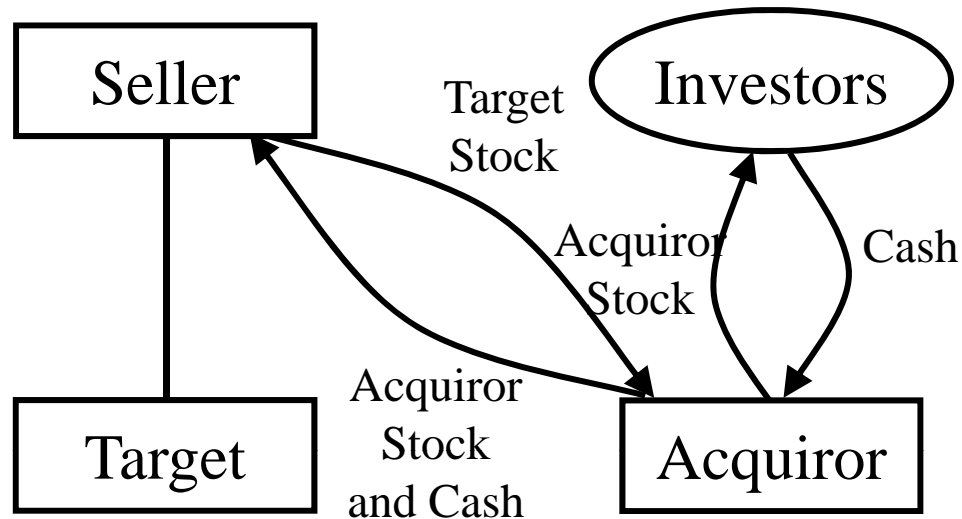

- Seller owns the stock of Target.
- Investors form Acquiror by contributing cash to Acquiror.
- Seller transfers its Target stock to Acquiror in exchange for Acquiror stock and cash.
- The transaction is a section 351 transaction. As a result, no section 338 election may be made. Under the proposed regulations, no section 336(e) election could be made either.
- Absent a section 336(e) election, Seller would recognize all the gain on its Target stock up to the amount of cash received (but no loss).
- If a section 336(e) election were permitted and were made, Target would recognize the gain and loss in its assets and then would be deemed to liquidate into Seller.

## Dispositions to Related Persons

- The legislative history contemplates that a disposition to a related person could be eligible for a section 336(e) election:
  - “The conferees intend that the regulations under this elective procedure will account for appropriate principles that underlie the liquidation-reincorporation doctrine. For example, *to the extent that regulations make available an election to treat a stock transfer of controlled corporation stock to persons related to such corporation within the meaning of section 368(c)(2)*, it may be appropriate to provide special rules for such corporation's section 381(c) tax attributes so that net operating losses may not be used to offset liquidation gains, earnings and profits may not be manipulated, or accounting methods may not be changed.”

## Dispositions to Related Persons

- The proposed regulations preclude a section 336(e) election if the stock is sold, exchanged or distributed to a related person. Prop. Reg. § 1.336-1(b)(4)(i)(C).
- The definition of related person is imported from section 338 and provides that two persons are related if stock owned by one of the persons would be attributed under section 318(a) (other than section 318(a)(4)) to the other. Prop. Reg. § 1.336-1(b)(ii).
- That definition of relatedness can have unanticipated consequences because section 318(a)(3) attributes from partners to partnerships regardless of how little the partner owns in the partnership.
  - Example: A widely held Seller Corp owns Target. Seller Corp wants to sell Target to a Buyer Corp owned by a private equity fund that is treated as a partnership for tax purposes. Seller Corp owns a small stake (say 0.5%) in the private equity fund. The sale might not be eligible for a section 338(h)(10) election. Under section 318(a)(3)(A), stock in *any corporation* owned by Seller Corp would be attributed to the private equity fund, and then (if the private equity fund owns at least 50 percent in value of the stock of Buyer Corp), under section 318(a)(3)(C), from the private equity fund to Buyer Corp.



## Intragroup Sale or Spin followed by External Sale or Spin

- If the stock of Target is transferred within an affiliated group and then transferred to a third party in a transaction for which a section 336(e) election is made, there could potentially be a double tax at the corporate level. Reg. § 1.1502-13(f)(5)(ii)(C) should ameliorate the double tax, however.
- Example:
  - Seller owns Sub 1 and Sub 2. Sub 1 owns Target. Sub 1 sells the stock of Target to Sub 2 for cash resulting in a deferred intercompany gain in the stock of Target. Then, Sub 2 sells the stock of Target in a separate transaction in which either a section 336(e) or a section 338(h)(10) election is made. The election results in recognition of gain in the assets of Target. Further, the deemed liquidation resulting from the election results in the deferred intercompany gain being taken into income. Thus, both asset level gain and stock level gain in Target are apparently recognized. However, Reg. § 1.1502-13(f)(5)(ii)(C) should permit the taxpayer to elect to treat the deemed liquidation of Target into Sub 2 as a section 331 liquidation for the sole purpose of providing Sub 2 with a loss, which offsets Sub 1's deferred intercompany gain that arose on the disposition of Target to Sub 2.

## Subchapter S Corporations

- Section 336(e) by its terms requires that stock in the target meeting the requirements of section 1504(a)(2) be owned by another corporation, and thus on its face does not apply to S corporation targets.
- The proposed regulations do not allow a section 336(e) election in the Subchapter S context. If a section 336(e) election were permitted in the case of a target S corporation, the election would avoid double tax on S corporation earnings, just as the election avoids triple tax on C corporation earnings.
- Section 338(h)(10) similarly requires the target to be a member of a “selling consolidated group,” which would preclude a section 338(h)(10) election in the case of a target S corporation. Reg. § 1.338(h)(10)-1(c) nevertheless permits section 338(h)(10) elections for target S corporations.
- Section 338(i) could provide authority for a section 336(e) election for a target S corporation.

# Section 336(e) Elections involving Foreign Corporations

- Under the proposed regulations, a section 336(e) election is only available where both the Seller and the Target are domestic corporations. Prop. Reg. §§ 1.336-1(b)(1) and (3).
- Section 338 elections apply to foreign and domestic target corporations. Is there a principled way to distinguish the section 336(e) election in this regard?
- Issues: U.S. Seller – Foreign Target
  - Gain on inbound section 332 liquidation (section 367(b))
  - Sourcing of earnings and profits for foreign tax credit purposes?
  - Application of section 338(h)(16) principles?
- Issues: Foreign Seller – U.S. Target
  - FIRPTA purge?
  - Avoid Subpart F income where Seller is a CFC?
  - Double taxation on “carried over” earnings and profits?
- Issues: Foreign Seller – Foreign Target
  - Expand the Dover Corp. v. Commissioner results to situations where a check-the-box election is unavailable?

Step Transaction Issues:  
Reorganizations

# Rev. Rul. 2001-26

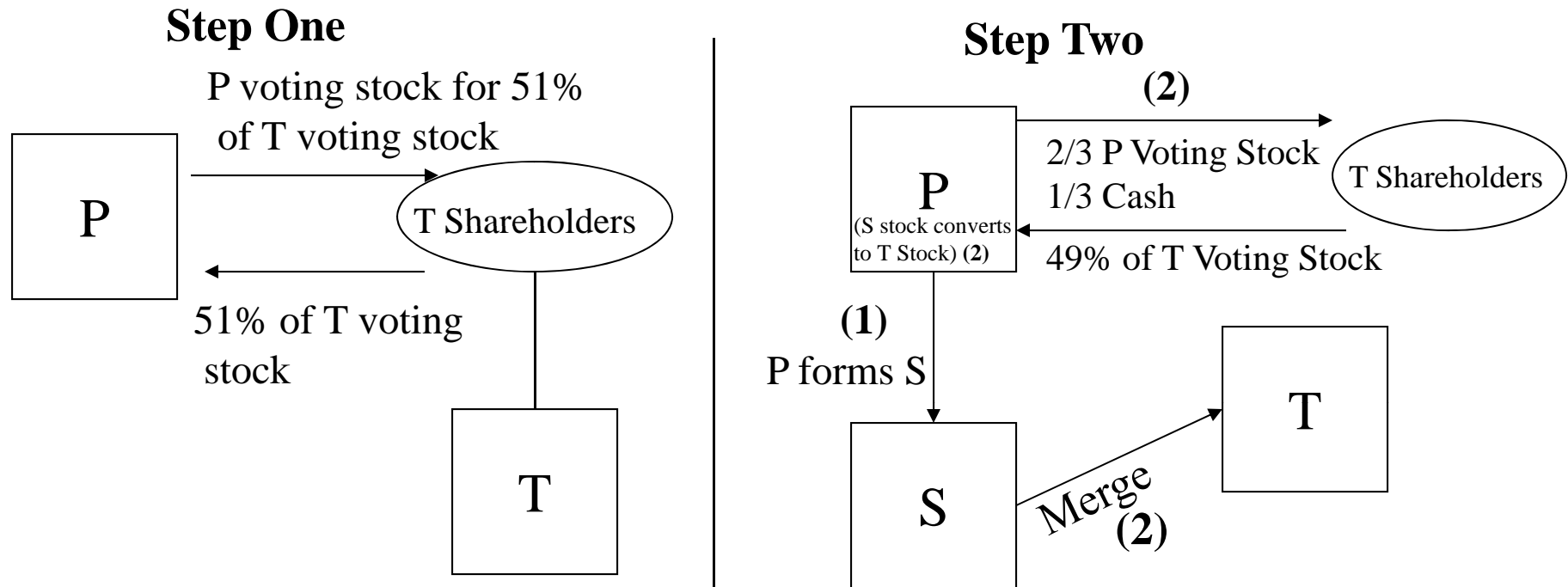

**Facts:** P and T are widely held manufacturing corporations organized under the laws of state A. T has only voting common stock outstanding, none of which is owned by P. P seeks to acquire all of T's outstanding stock. For valid business reasons, the acquisition will be effected by a tender offer for at least 51% of T's stock, to be acquired solely for P voting stock, followed by a merger of S, P's newly formed wholly owned subsidiary, into T. Pursuant to the tender offer, P acquires 51% of T's stock from T's shareholders for P voting stock. P then forms S which merges into T in a statutory merger under the laws of state A. In the merger, P's S stock is converted into T stock and each of the T shareholders holding the remaining 49 percent of the outstanding T stock exchanges its shares of T stock for a combination of consideration, two-thirds of which is P voting stock and one-third of which is cash. Assume (i) that the tender offer and merger are treated as an integrated acquisition by P of all of the T stock, and (ii) that all nonstatutory requirements under sections 368(a)(1)(A) and 368(a)(2)(E), and all statutory requirements under section 368(a)(2)(E), other than the requirement that P acquire control of T in exchange for its voting stock, are satisfied. Assume the same facts, except what if S initiates the tender offer for T stock and, in the tender offer, acquires 51% of the T stock for P stock provided by P?

## King Enterprises

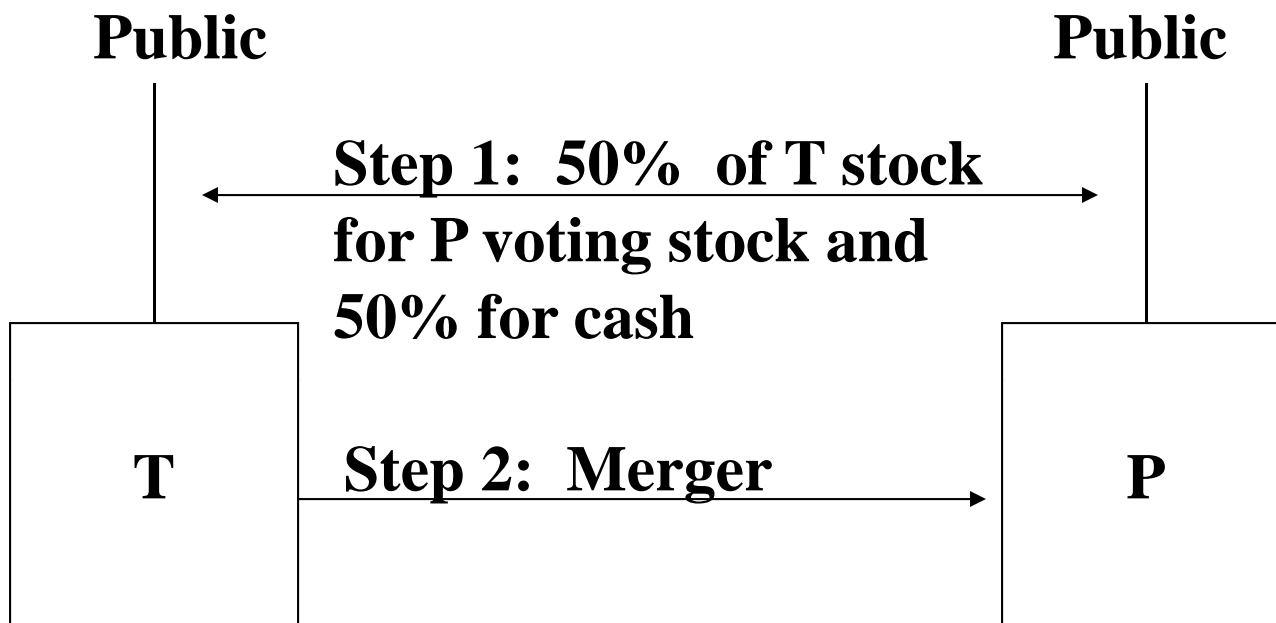

**Facts:** The shareholders of T exchange all of their T stock for consideration consisting of 50% P voting stock and 50% cash. Immediately following the exchange, and as part of the overall plan, P causes T to merge upstream into P. The transaction should qualify as an “A” reorganization. See King Enterprises, Inc. v. United States, 418 F.2d 511 (Ct. Cl. 1969); Rev. Rul. 2001-26, 2001-23 I.R.B. 1.

# Rev. Rul. 2001-46 - Situation 1

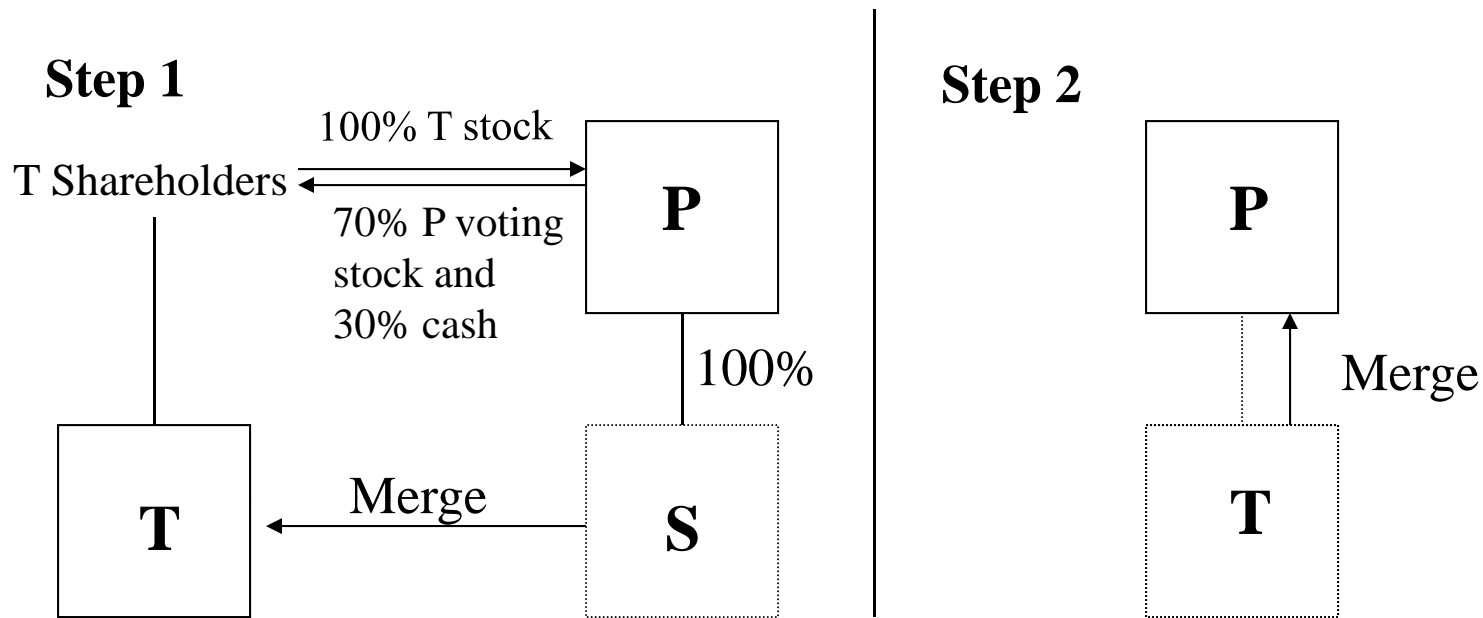

**Facts:** P owns all of the stock of S, a newly formed wholly owned subsidiary. Pursuant to an integrated plan, P acquires all of the stock of T, an unrelated corporation, in a statutory merger of S into T, with T surviving. In the merger, the T shareholders exchange their stock for consideration of 70% P voting stock and 30% cash. Immediately thereafter, T merges upstream into P.

**Result:** If the acquisition were viewed independently from the upstream merger of T into P, the result should be a QSP of T stock followed by a section 332 liquidation. See Rev. Rul. 90-95, 1990-2 C.B. 67. However, because step transaction principles apply, see King Enterprises, Inc. v. United States, 418 F.2d 511 (Ct. Cl. 1969), the transaction is treated as a single statutory merger of T into P under section 368(a)(1)(A). P acquires the T assets with a carry-over basis under section 362, and P may not make a section 338 election for T.

**Note:** On July 8, 2003, the Service issued new final and temporary regulations that permit taxpayers to turn off the step transaction doctrine and to make a section 338(h)(10) election in the transaction described above. See Treas. Reg. § 1.338-3(c)(1)(i), (2) and Temp. Treas. Reg. § 1.338(h)(10)-1T.

## Treas. Reg. § 1.338(h)(10)-1(c)(2), (e)

- The IRS issued final regulations on July 3, 2006, which adopt the substance of temporary and proposed regulations issued in 2003.
- The regulations provide that “a section 338(h)(10) election may be made for T where P’s acquisition of T stock, viewed independently, constitutes a qualified stock purchase and, after the stock acquisition, T merges or liquidates into P (or another member of the affiliated group that includes P) . . . ” Treas. Reg. § 1.338(h)(10)-1(c)(2).
  - This rule applies regardless of whether, under the step transaction doctrine, the acquisition of T stock and subsequent merger or liquidation of T into P (or P affiliate) qualifies as a reorganization under section 368(a). *Id.*
  - If a section 338(h)(10) election is made under these facts, P’s acquisition of T stock will be treated as a qualified stock purchase (a “QSP”) for all Federal tax purposes and will not be treated as a reorganization under section 368(a). See Treas. Reg. § 1.338(h)(10)-1(e), Ex. 12 & 13.
  - However, if taxpayers do not make a section 338(h)(10) election, Rev. Rul. 2001-46 will continue to apply so as to recharacterize the transaction as a reorganization under section 368(a). See *id.* at Ex. 11.
- In issuing the regulations, the IRS rejected a recommendation that the final regulations allow section 338(g) elections, as well as section 338(h)(10) elections, to turn off the step transaction doctrine, because extending the election as such would allow the acquiring corporation to unilaterally elect to treat the transaction, for all parties, as other than a reorganization under section 368(a).
- The IRS stated in the Preamble that it would continue to study whether the corporate purchaser requirement of -3(b) should be amended (e.g., an individual cannot make a QSP, although an individual can form a corporation to satisfy the QSP requirement if that corporation is treated as purchasing the target stock, which it may not be if that corporation liquidates following the stock purchase).
- The regulations are effective for stock acquisitions occurring on or after July 5, 2006.



## Rev. Rul. 2001-46 - Situation 2

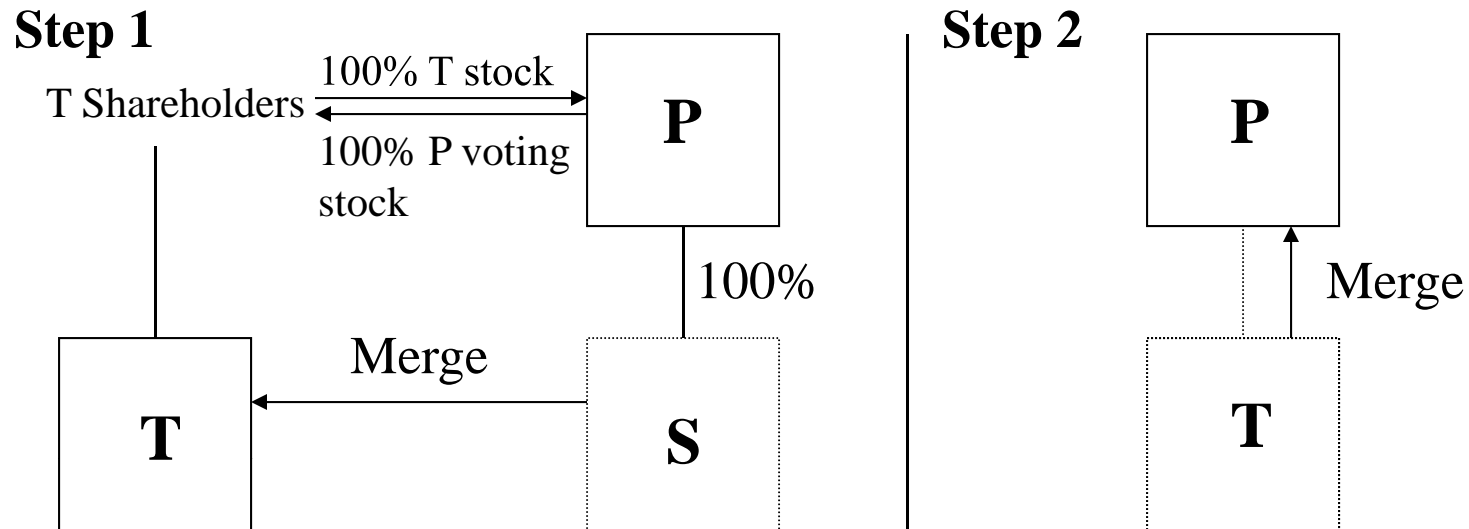

**Facts:** Same facts as in Situation 1, except that the T shareholders receive solely P stock in exchange for their T stock, so that the merger of S into T, if viewed independently of the upstream merger of T into P, would qualify as a reorganization under section 368(a)(1)(A) by reason of section 368(a)(2)(E).

**Result:** Step transaction principles apply to treat the transaction as a merger of T directly into P.

**Note:** The taxpayers cannot not change this result under the new section 338 regulations because, standing alone, P's acquisition of T does not constitute a qualified stock purchase.

## King Enterprises Transaction – Variation 1

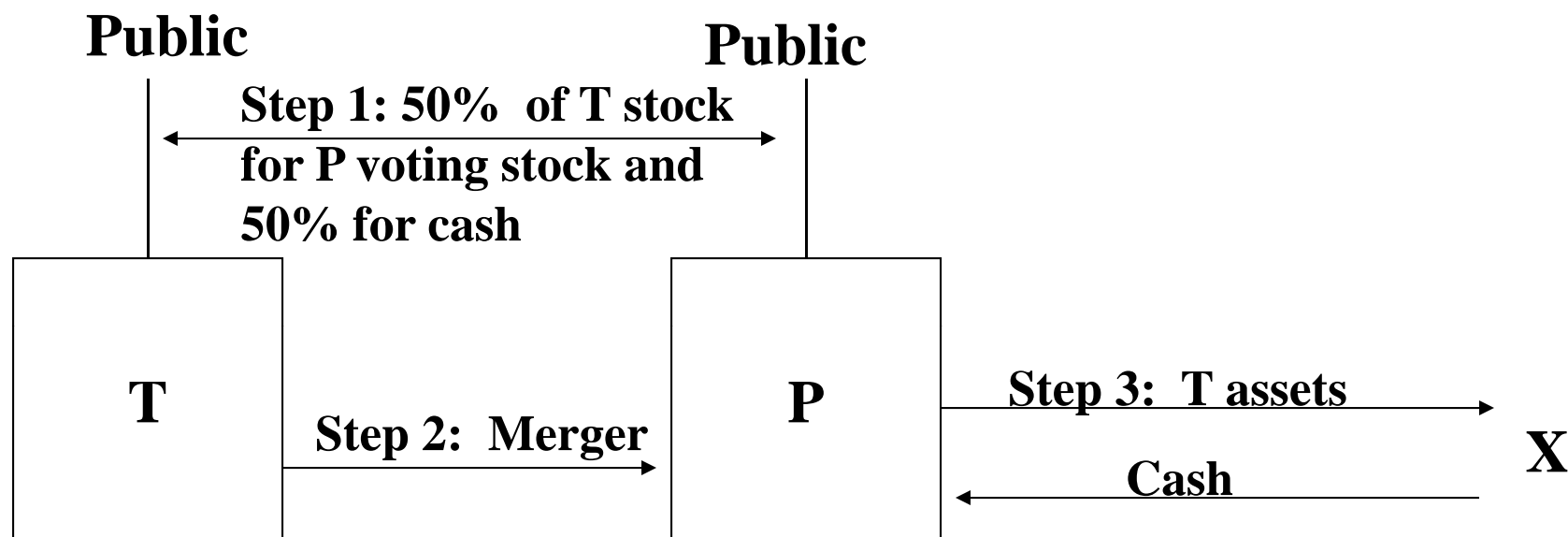

**Facts:** Same facts as in the *King Enterprises* slide, except P sells T's assets to X a third party immediately after the merger of T into P.

**Questions:** (1) Does the Step-Transaction Doctrine apply?

(2) What is the result of this transaction for Federal income tax purposes?

# Rev. Rul. 2008-25

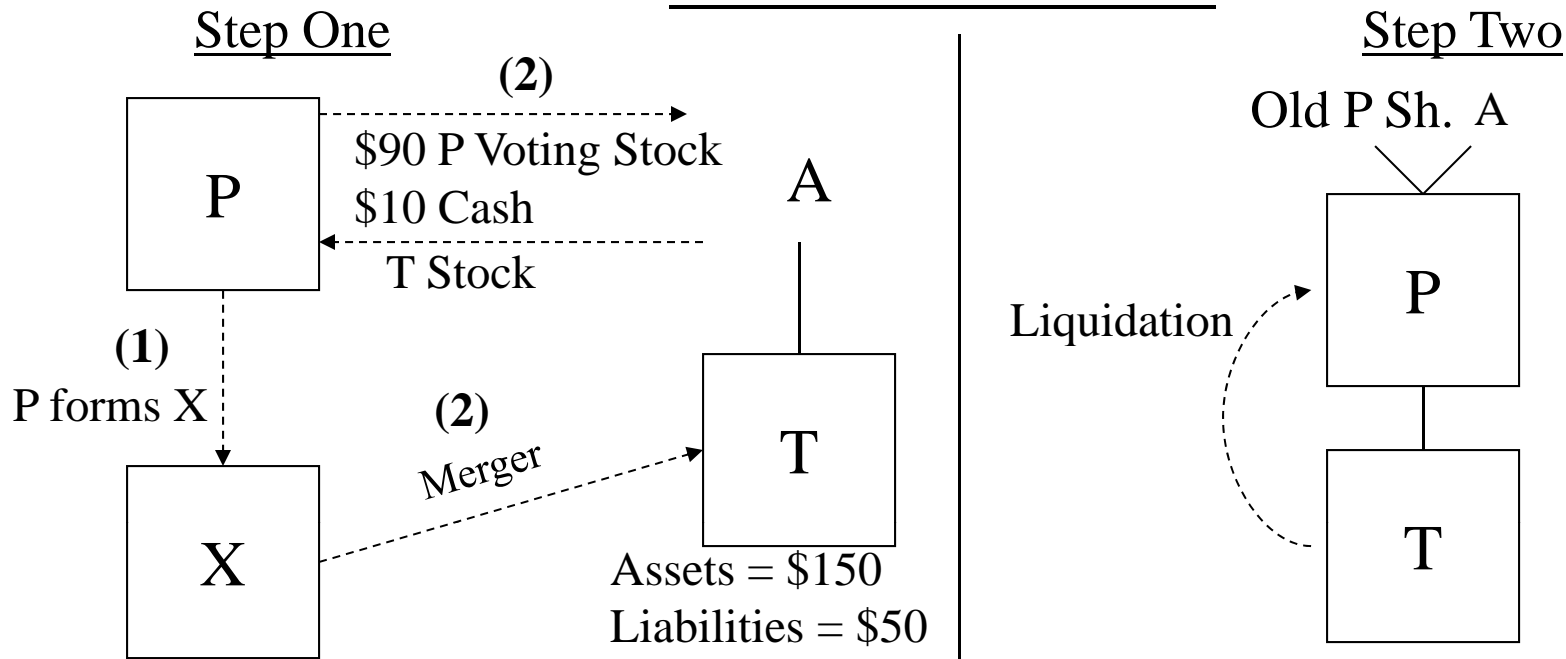

**Facts:** A, an individual, owns all of the stock of T. T holds assets worth \$150 and has \$50 of liabilities. P, an unrelated corporation, has net assets worth \$410. P forms X for the sole purpose of acquiring the stock of T in a reverse subsidiary merger. In the merger, P acquires all of the stock of T, and A exchanges the T stock for \$10 in cash and P voting stock worth \$90. Following the merger and as part of an integrated plan that included the merger, T completely liquidates into P. In the liquidation, T transfers all of its assets to P, and P assumes all of T's liabilities.

**Result:** The merger does not constitute a tax-free reorganization because T's liquidation does not fall within the safe harbor from the application of the step transaction doctrine (*i.e.*, Treas. Reg. § 1.368-2k). When the merger and liquidation are integrated, the transaction fails the requirements of a tax-free reverse subsidiary merger set forth in section 368(a)(2)(E) because T does not hold substantially all of its properties and the properties of the merged corporation. Moreover, viewing the merger and the liquidation as integrated steps does not cause the transaction to be treated as a tax-free "A", "C" or "D" reorganization or a section 351 exchange. For example, the transaction would not constitute a tax-free "C" reorganization because 40% of the consideration exchanged by P is not solely P voting stock (*i.e.*, \$50 assumption of liabilities and \$10 cash). The deemed taxable exchange of T assets to P would not permit P to obtain a cost basis in the T assets because Rev. Rul. 90-95 and Treas. Reg. § 1.338-3(d) reject the step transaction approach in so far as a taxpayer may obtain a cost basis in assets acquired in a stock purchase in absence of a section 338 election.

## King Enterprises Transaction – Variation 2

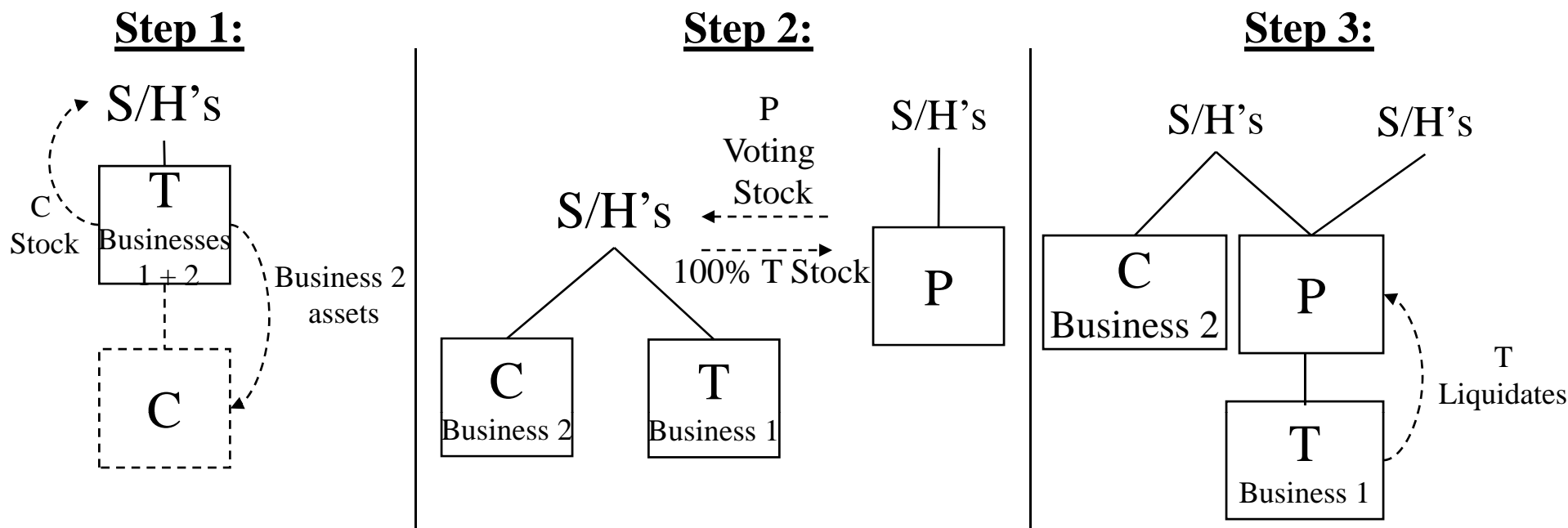

**Facts:** T currently operates two businesses. T contributes all of its Business 2 assets to C, a newly formed wholly owned subsidiary. T distributes the stock of C to T shareholders in a spin-off. P acquires T from the T shareholders in exchange for P stock. Immediately thereafter, T is liquidated into P.

**Form:** The above steps in form constitute a section 355 transaction, a B reorganization, and a section 332 liquidation.

**Result:** Step transaction principles apply to treat P's acquisition of T as if: (1) P acquired a portion of T's assets (Business 1) and (2) T liquidated. *See Rev. Rul. 67-274; Elkhorn Coal.* Under Rev. Rul. 67-274, P's acquisition of T is not a valid B reorganization. Because T liquidates into P, Rev. Rul. 67-274 combines the steps and treats the transaction as an acquisition by P of T's Business 1 assets. In this transaction, the acquisition does not qualify as a C reorganization because *Elkhorn Coal* steps together the spin-off and the acquisition such that P cannot be said to acquire substantially all of T's assets. Therefore, the transaction will be a taxable acquisition and not a tax-free reorganization.

**Issue:** Can P's acquisition of T be treated as a qualified stock purchase followed by a section 332 liquidation?

*See Rev. Rul. 2001-46; Treas. Reg. § 1.338-3(c)(1)(i), (2); Treas. Reg. § 1.338(h)(10)-1(c)(2), (e).*

## Falconwood

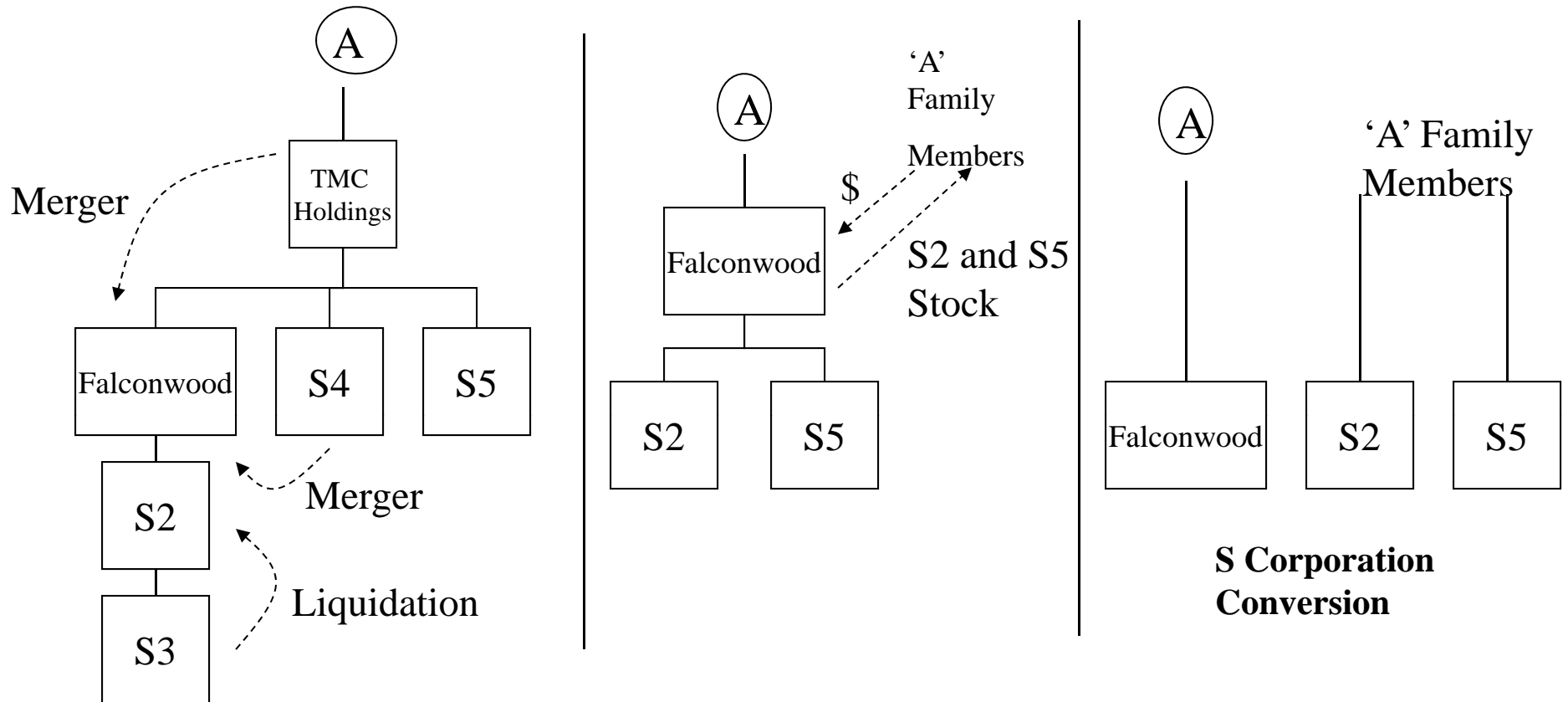

**Facts:** TMC Holdings filed a consolidated return as parent of a consolidated group consisting of TMC Holdings, Falconwood, S2, S3, S4 and S5 for years prior to 1986. TMC Holdings is owned by an individual, A, and related familial trusts (collectively (“A”)). In 1986, A decided to restructure the ownership of the group so that the surviving corporations could elect S corporation status. The Tax Reform Act of 1986 imposed a corporate level tax on pre-election gains when a C corporation elected S corporation status, and was effective for conversions occurring prior to December 31, 1986. To avoid the additional tax, TMC Holdings merged downstream into Falconwood on December 23, 1986. That same day, S4 also merged into Falconwood and S3 liquidated into S2. At the end of the day, Falconwood sold the stock of S2 and S5 to members of A’s family and each company was set up to allow S Corporation elections effective January 1, 1987. Falconwood filed a consolidated return in which it claimed a loss incurred after the merger, which was also used to claim refunds for prior taxable years.

## *Falconwood*

**Taxpayer Position:** Falconwood took the position that the consolidated group survived the termination of TMC Holdings, the parent of the group, because the remaining members (Falconwood, S2 and S5) succeeded to the assets of TMC Holdings, and both S2 and S5 remained connected as subsidiaries to the new common parent, Falconwood, for a period of three hours that ended upon the sale of stock of S2 and S5 to members of A's family.

**Result:** In *The Falconwood Corp. v. United States*, 2005-2 U.S.T.C. (CCH) ¶ 50,597 (Fed. Cir. 2005) the Court of Appeals, Federal Circuit reversed and remanded the lower court decision, holding in favor of Falconwood. The Court of Appeals held that the affiliated group (with TMC Holdings as parent) satisfied the requirements of Treas. Reg. § 1.1502-75(d)(2)(ii), which provides that an affiliated group will stay in existence even if the former common parent is terminated, if the members of the group succeed to the assets of such former common parent and the members of the affiliated group remain connected through common ownership through a new common parent. The lower court had held that the provision implied a temporal requirement. In finding in favor of Falconwood, the Court of Appeals did not apply the step-transaction doctrine to disregard the intermediate step lasting merely three hours that maintained an affiliated group after the initial mergers and liquidation. The Court observed that the downstream merger of TMC Holdings into Falconwood possessed an independent business purpose, since it avoided the risk and delay incident to obtaining regulatory approval.

Step Transaction Issues:  
Sections 302, 304, and 305

## Bootstrap Acquisition

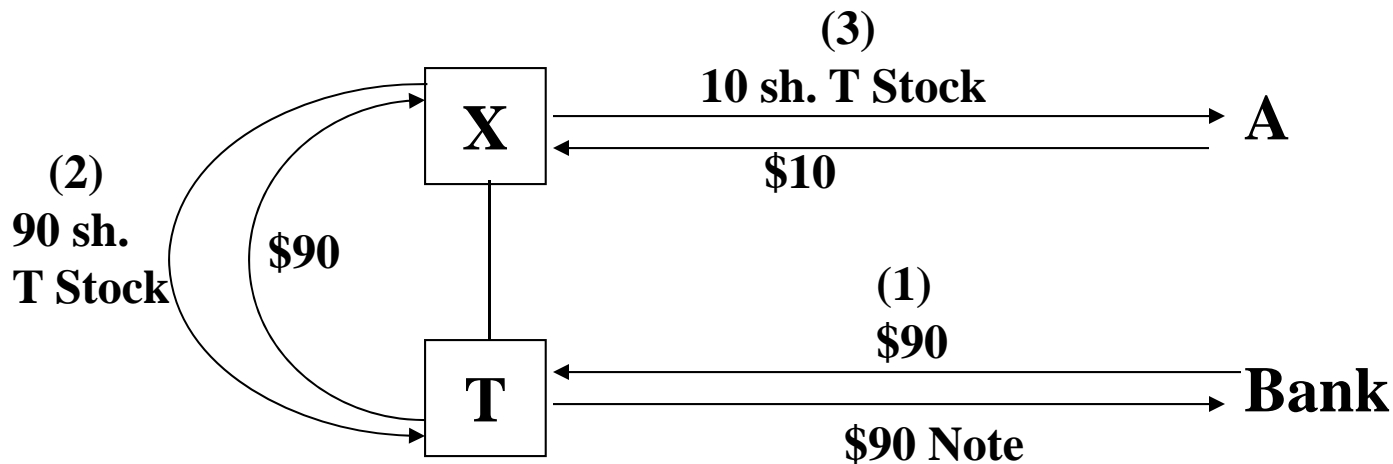

X wants to sell all the stock of T (100 shares). X and A informally agree on a \$100 price.

- (1) T borrows \$90 from Bank.
- (2) T redeems 90 shares of its stock from X for \$90.
- (3) X and A sign an agreement, and A buys X's remaining 10 shares of T stock for \$10.

Variations:

- Instead of redeeming stock, T distributes \$90 to X; A buys 100 shares for \$10.
- X and A sign the agreement before step (2).

*Zenz v. Quinlivan*, 213 F.2d 914 (6th Cir. 1954); *Waterman S.S. Corp. v. Comm'r*, 430 F.2d 1185 (5th Cir. 1970); *TSN Liquidating Corp. v. U.S.*, 624 F.2d 1328 (5th Cir. 1980); *Litton Ind. Inc. v. Comm'r*, 89 T.C. 1086 (1987); *Durkin Est. v. Comm'r*, 99 T.C. 561 (1992); *Uniroyal Inc. v. Comm'r*, T.C. Memo. 1993-214; Rev. Rul. 69-608, 1969-2 C.B. 42; Rev. Rul. 75-447, 1975-2 C.B. 113; Rev. Rul. 75-493, 1975-2 C.B. 108; Rev. Rul. 77-226, 1977-2 C.B. 90



# Bootstrap Acquisition with Section 351 Exchange

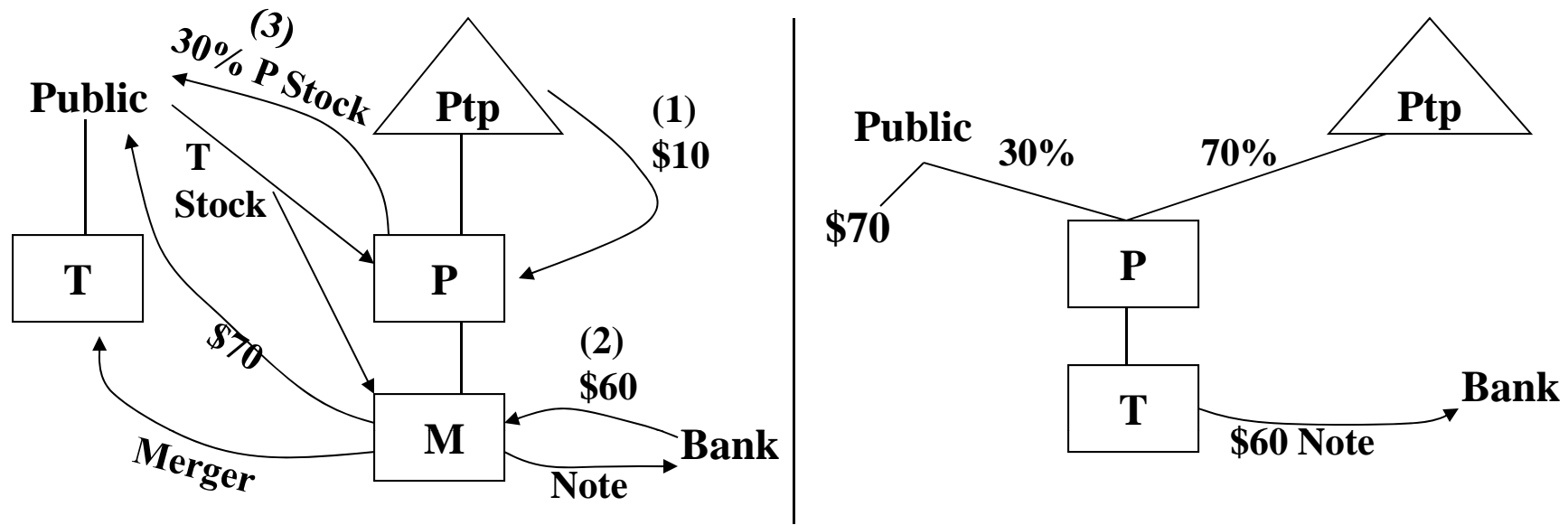

Ptp acquires T from the public for \$700 cash, with the T shareholders retaining a 30% interest in T.

- (1) Ptp forms P and contributes \$10 cash to P.
- (2) M borrows \$60 cash from Bank.
- (3) M merges into T.
  - P’s M stock is converted into all the stock of T.
  - The public receives \$70 cash and 30% of the stock of P. Each shareholder may elect to receive cash, P stock or a combination, subject to pro ration.
  - T becomes the obligor on M’s debt to Bank.

Variation: Suppose Ptp or one of its partners owns 1 share of T stock.

Sections 302, 304, 351

Rev. Ruls. 78-250, 69-608

## Merrill Lynch v. Commissioner

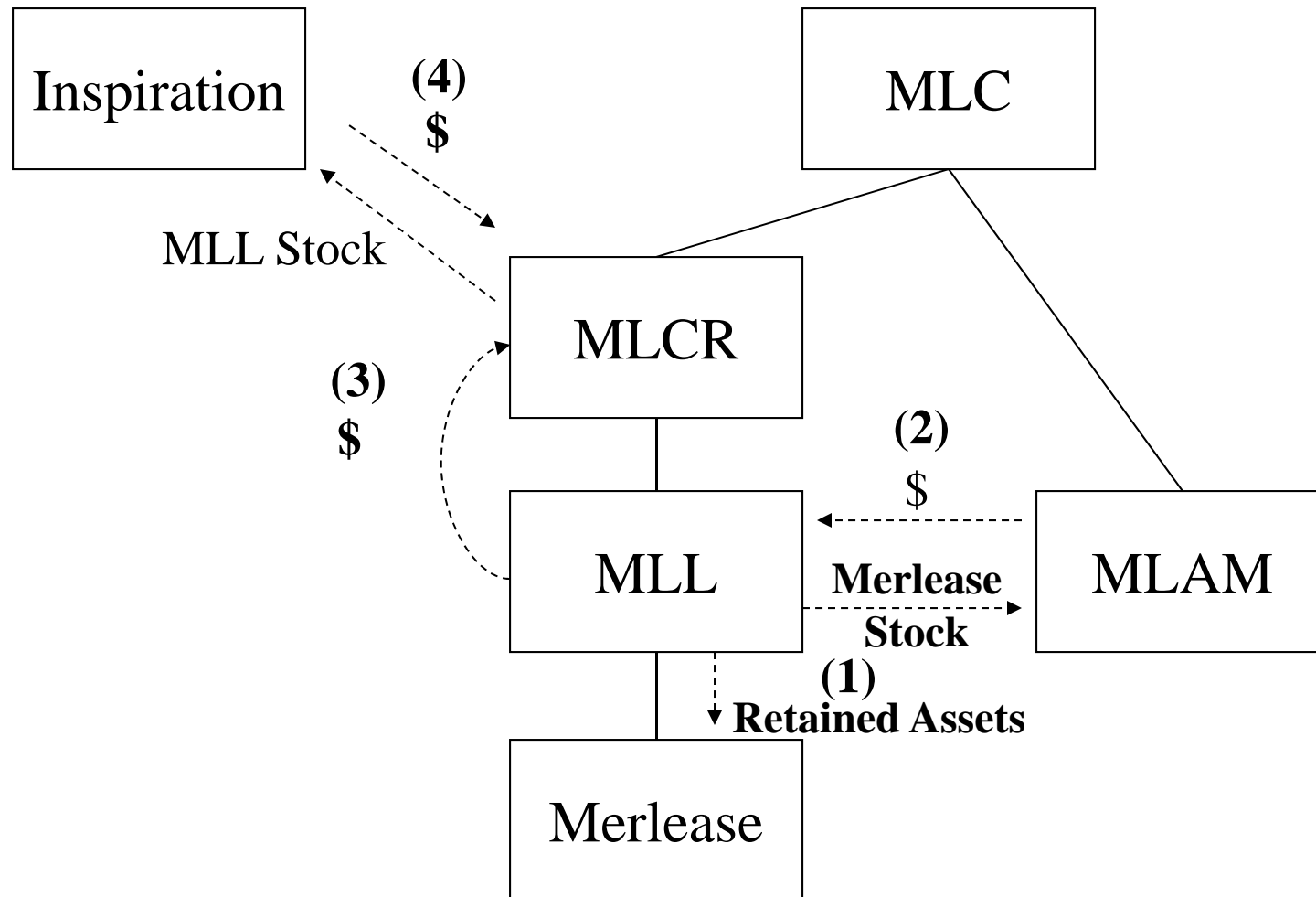

MLC group wishes to sell the stock of MLL to Inspiration, an unrelated party, but retain certain MLL assets.

- (1) MLL contributes to Merlease the assets that MLC wants to retain.
- (2) MLL sells Merlease cross-chain to a sister subsidiary, MLAM, in a section 304 transaction.
- (3) MLL distributes the sale proceeds to MLCR as a dividend.
- (4) MLCR sells MLL to Inspiration.

*Merrill Lynch & Co. v. Commissioner*, 386 F.3d 464 (2d Cir. 2004), *aff'g in part and remanding* 120 T.C. 12 (2003),  
Supp on remand 131 T.C. No. 19 (2008).

## *Merrill Lynch v. Commissioner*

**Position of Merrill Lynch:** Under the consolidated return regulations in effect during 1986, Merrill Lynch took the position that the cross-chain sale of Merlease and the dividend to MLCR should be treated as a deemed redemption under section 304 subject to dividend treatment under section 301. Merrill Lynch argued that the transaction did not qualify for sale or exchange treatment under section 302 due to the fact that MLL's interest in Merlease was not terminated at the time of the cross-chain sale. Therefore, Merrill Lynch claimed that MLCR was entitled to a step-up in its basis in its MLL stock to the extent of the dividend and recognized a loss on its sale of MLL stock to Inspiration.

**Decision of Tax Court:** The Tax Court ruled that the cross-chain sale, dividend, and sale of MLL to Inspiration were steps in a plan to terminate MLL's ownership of Merlease and the section 304 redemption was therefore subject to sale or exchange treatment because it represented a complete termination of MLL's interest in Merlease under section 302(b)(3). The Court concluded that the cross-chain sale and sale of MLL to Inspiration represented a "firm and fixed" plan to terminate MLL's interest in Merlease for purposes of determining whether the section 304 redemption should be treated as a sale or exchange or a dividend. *See Zenz v. Quinlivan*, 213 F.2d 914 (6<sup>th</sup> Cir. 1954); *Niedermeyer v. Commissioner*, 62 T.C. 280 (1974). In reaching its decision, the Court focused on the fact that the complete plan to sell MLL was presented to Merrill Lynch's board of directors only four days after the cross-chain sale and while the sale was not finalized, it was sufficiently mature at that time that a tax reserve for the transaction was established.

## *Merrill Lynch v. Commissioner*

**Decision of Second Circuit:** The Second Circuit affirmed the Tax Court decision finding that there was a “firm and fixed” plan to sell MLL at the time of the cross-chain sale and, thus, the cross-chain sale qualified for sale or exchange treatment.

**Additional Merrill Position:** On appeal, Merrill Lynch took the position that for section 302 purposes, the stock ownership of the parent company, MLC, was to be considered rather than the stock ownership of MLL. Because the issue of law was first raised on appeal, the Second Circuit remanded the issue back to the Tax Court. The Tax Court rejected this position and held that MLL’s lack of continuing ownership of the Merlease stock was dispositive.

# PLR 201002022 – Sections 302, 305

## Redemption and Deemed Distribution

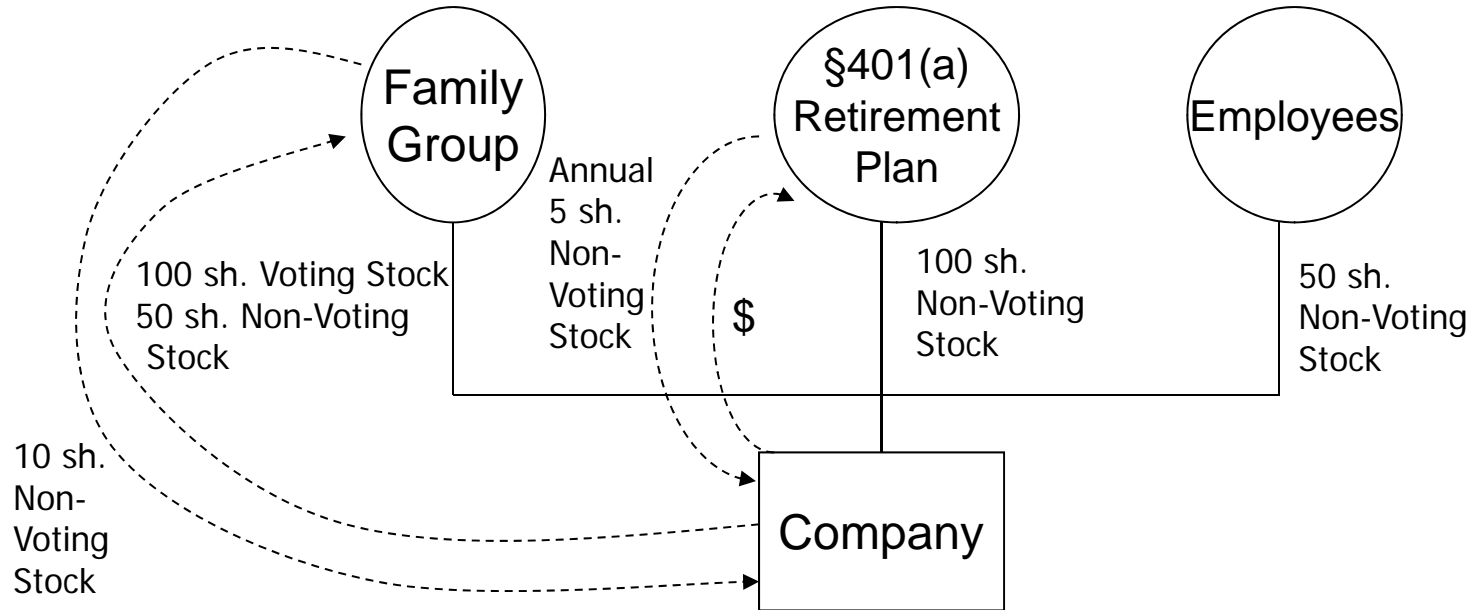

- Family Group owns all 100 outstanding shares of Company voting stock.
- The nonvoting stock of Company is owned as follows:
  - Family Group 50 shares
  - 401(a) Retirement Plan 100 shares
  - Employees 50 shares
- Company redeems 5 shares of nonvoting stock from Retirement Plan annually to fund retirement payments to employees.
- Company redeems 10 shares of nonvoting stock from members of Family Group (represented to be “functionally unrelated” to redemptions from Retirement Plan and an “isolated transaction”).

## PLR 201002022 – Sections 302, 305 Redemption and Deemed Distribution

- IRS rules that annual redemptions from Retirement Plan are taxed under section 302 as stock sales, not section 301 distributions. Does it matter?
- IRS rules that the redemptions do not result in deemed distributions to non-redeeming shareholders under section 305(c).
- IRS does not rule on whether redemptions from the Family Members are taxed under section 302 as stock sales or as section 301 distributions.
- If there were any section 305(c) deemed distributions, which would be the non-redeeming shareholders?
- See Jasper L. Cummings, “Serving Different Flavors of Redemption,” Federal Tax Updates from Checkpoint (Jan. 20, 2010); Robert Willens, “‘Isolated’ Redemptions Do Not Trigger Constructive Distributions,” 25 DTR J-1 (Feb. 9, 2010)

## 'D' Reorganizations

## 'D' Reorganizations – Stock

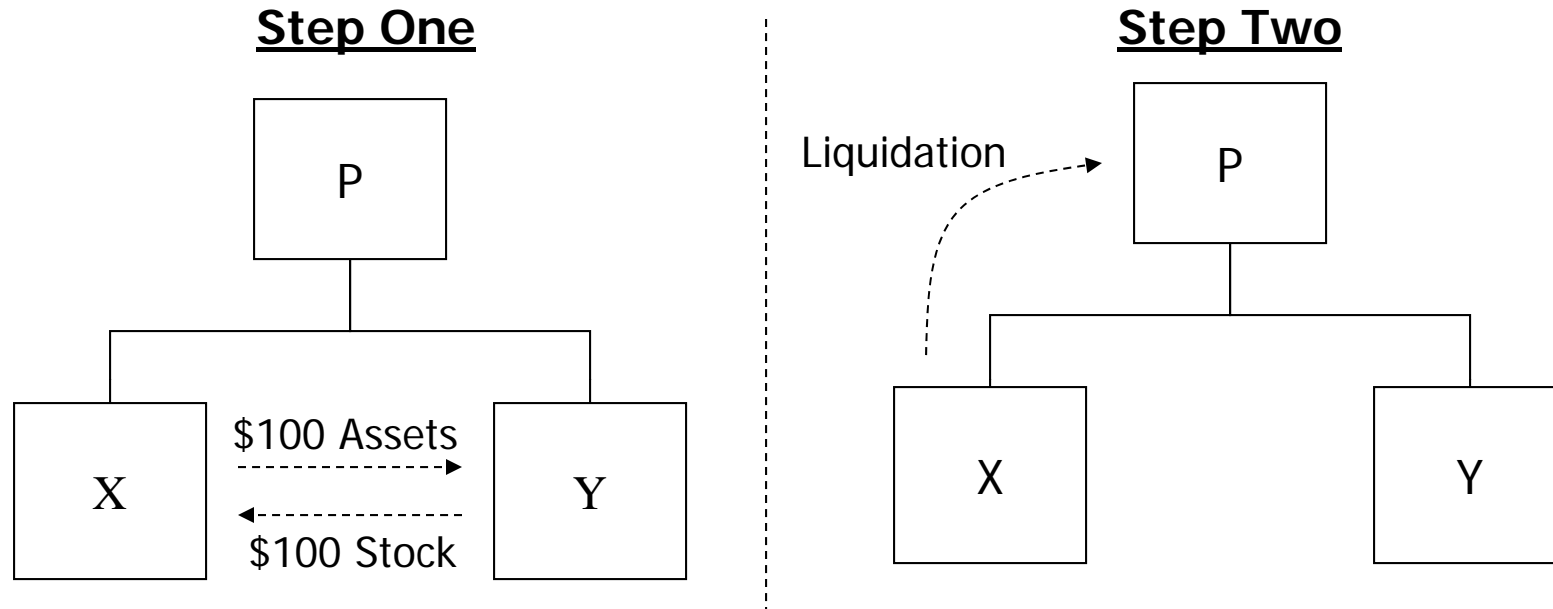

**Facts:** P owns all of the stock of X and Y. X transfers all \$100 of its assets to Y in exchange for \$100 worth of Y stock. X then liquidates into P.

**Result:** This transaction qualifies as a tax-free 'D' reorganization under section 368(a)(1)(D). A transfer by one corporation (X) of substantially all of its assets to another corporation (Y) qualifies as a reorganization described in section 368(a)(1)(D) if, immediately after the transfer, one or more of the transferor corporation's shareholders (P) is in control of the acquiring corporation (Y), and if stock or securities of the acquiring corporation (Y) are distributed in a transaction which qualifies under section 354, 355, or 356. See Section 354(b)(1).



## 'D' Reorganizations – Rev. Rul. 70-240

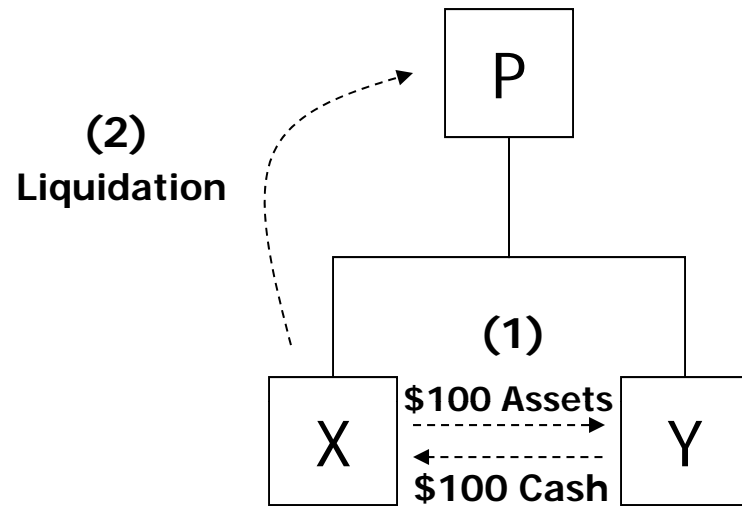

**Facts:** P owns all of the stock of X and Y. X transfers all \$100 of its assets to Y in exchange for \$100 cash. X then liquidates into P.

**Result:** This transaction qualifies as a tax-free 'D' reorganization under section 368(a)(1)(D). In the transaction, X transfers substantially all of its assets to Y and X's shareholder (P) is in control of Y after the exchange. However, the requirement that stock or securities of the acquiring corporation (Y) be distributed is not technically satisfied. This requirement is treated as satisfied because a distribution of Y stock in this example would be a meaningless gesture, even though the cash represents the full value of the transferred assets. See Rev. Rul. 70-240; see also Rev. Rul. 2004-83.

## ‘D’ Reorganizations – Regulations

- On December 18, 2006, Treasury and the IRS issued temporary regulations under sections 368(a)(1)(D) and 354(b)(1)(B) in response to requests for immediate guidance regarding whether certain all-cash acquisitive transactions can qualify as a ‘D’ reorganization. See Temp. Reg. § 1.368-2T(1).
  - The temporary regulations provided that a transaction may be treated as satisfying the requirements of sections 368(a)(1)(D) and 354(b)(1)(B) even if there is no actual issuance of stock and/or securities of the transferee corporation if the same person or persons own, directly or indirectly, all of the stock of the transferor and transferee corporations in identical proportions.
  - In such cases, transferee will be deemed to issue a nominal share of stock to the transferor corporation in addition to the actual consideration exchanged for the transferor’s assets.
- On March 1, 2007, Treasury and the IRS amended the temporary regulations so that certain related-party triangular reorganizations that qualify as tax-free triangular reorganizations under section 368 would not be treated as ‘D’ reorganizations with boot under the temporary regulations.
- On December 17, 2009, Treasury and the IRS issued final regulations on the treatment of transactions as acquisitive ‘D’ reorganizations where no stock and/or securities of the transferee is issued and distributed in the transaction.
  - The final regulations provide for the treatment of all-cash ‘D’ reorganizations as well as ‘D’ reorganizations in which the transferor receives no consideration or consideration with a FMV less than the FMV of the assets transferred.
  - The final regulations also confirm the determination of basis in stock of the transferee and the treatment where the reorganization involves consolidated group members.

## 'D' Reorganization Regulations – Nominal Share and Deemed Stock Rule

- The final regulations adopt the general approach set forth in the temporary regulations and deem the issuance of stock where no stock and/or securities are issued and distributed in the transaction, provided that the same person or persons own, directly or indirectly, all of the stock of the transferor and transferee in identical proportions.
- The final regulations clarify that the transferee will only be deemed to issue a nominal share if the transferor corporation receives full consideration in exchange for its assets.
- In cases where no consideration is received, or the FMV of the consideration received is less than the FMV of the transferor's assets, the transferee is treated as issuing stock with a value equal to the excess of the value of the assets over the value of the consideration received.
- The nominal share or the deemed stock will be deemed to be distributed by the transferor corporation in satisfaction of the distribution requirement under section 354(b)(1)(B), and then further transferred through chains of ownership to reflect the actual ownership of the transferor and transferee.

## 'D' Reorganization Regulations – Nominal Share and Deemed Stock Rule

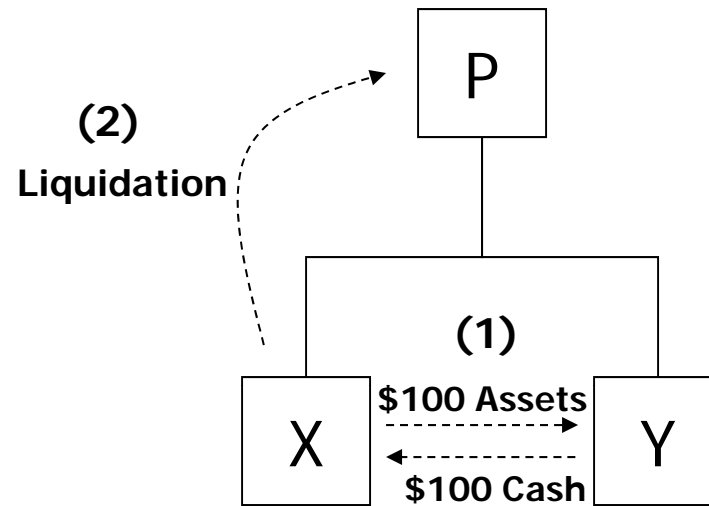

**Facts:** P owns all of the stock of X and Y. X transfers all \$100 of its assets to Y in exchange for \$100 cash and immediately liquidates into S.

**Result:** The transaction will be treated as a 'D' reorganization because there is complete shareholder identity and proportionality of ownership in X and Y. See Reg. § 1.368-2(1)(2); Cf. Reg. § 1.368-2(1)(3), ex. 1. Y is deemed to issue a nominal share of Y stock to X in addition to the \$100 cash, and X is deemed to distribute the nominal share and \$100 to P.

What if Y transferred only \$50 cash to X?

# ‘D’ Reorganization Regulations – Shareholder Identity/Proportionality

- The constructive ownership rules of section 318 apply with modification.
  - Section 318(a)(1) applies such that an individual and all members of his or her family described in section 318(a)(1) will be treated as one individual.
  - Section 318(a)(2) applies without regard to the 50-percent limitation in section 318(a)(2)(C).
- De minimis variation in shareholder identity or proportionality of ownership is permitted.
  - The final regulations do not define what level of variation would be treated as de minimis, although an example does conclude that a 1% ownership in the stock of the transferee by an individual who owns no stock in the transferor is de minimis variation in identity and proportionality where the other three shareholders own 34%, 33%, and 33% of the stock of the transferor and each owns 33% of the stock of the transferee.  
See Reg.  
§ 1.368-2(1)(3), ex. 4.
- Section 1504(a)(4) stock is not taken into account.

## 'D' Reorganization Regulations – Constructive Ownership

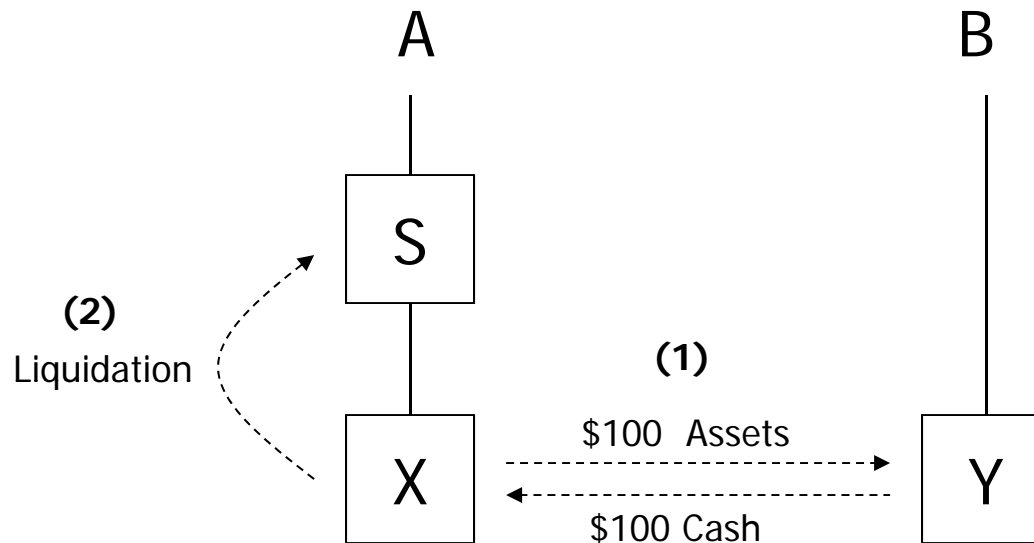

**Facts:** A and B are mother and son. A owns the stock of S which owns the stock of X. B owns the stock of Y. X transfers all \$100 of its assets to Y in exchange for \$100 cash and immediately liquidates into S.

**Result:** The final regulations adopt the constructive ownership rules of section 318(a)(1) to treat A and B as the same person and, thus, there is complete shareholder identity and proportional ownership in X and Y. The transaction is treated as a valid 'D' reorganization under the final regulations. S is deemed to distribute the nominal Y share to A, who in turn, is deemed to transfer the nominal Y share to B. See Reg. § 1.368-2(1)(3), ex. 2; see also PLR 9111055.

## 'D' Reorganization Regulations – De Minimis Variation in Ownership

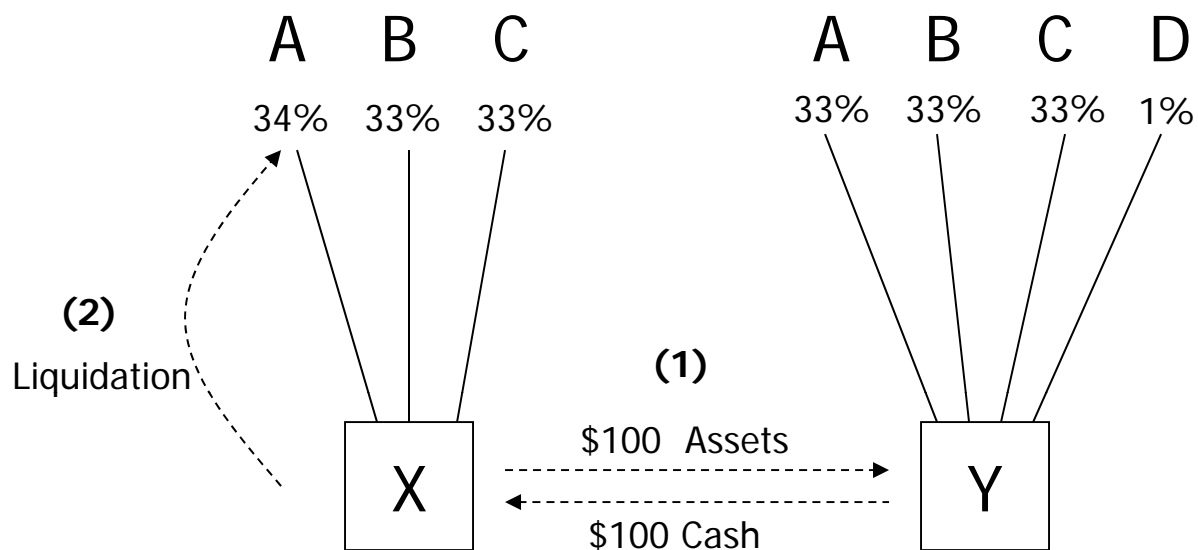

**Facts:** A, B, and C own 34%, 33%, and 33%, respectively, of the stock of X. A, B, and C each own 33% of the stock of Y; D owns the remaining 1%. X transfers all \$100 of its assets to Y in exchange for \$100 cash and immediately liquidates.

**Result:** D's ownership of 1% of Y stock is considered de minimis and, thus, there is complete shareholder identity and proportional ownership in X and Y. The transaction is treated as a valid 'D' reorganization under the final regulations. X is deemed to distribute the nominal Y share to A, B, and C in liquidation; the nominal share is deemed transferred among the Y shareholders to the extent necessary to reflect their actual ownership of Y. See Reg. § 1.368-2(1)(3), ex. 4.

What if D owned preferred stock of Y?

## 'D' Reorganization Regulations – Lack of Shareholder Identity/Proportionality

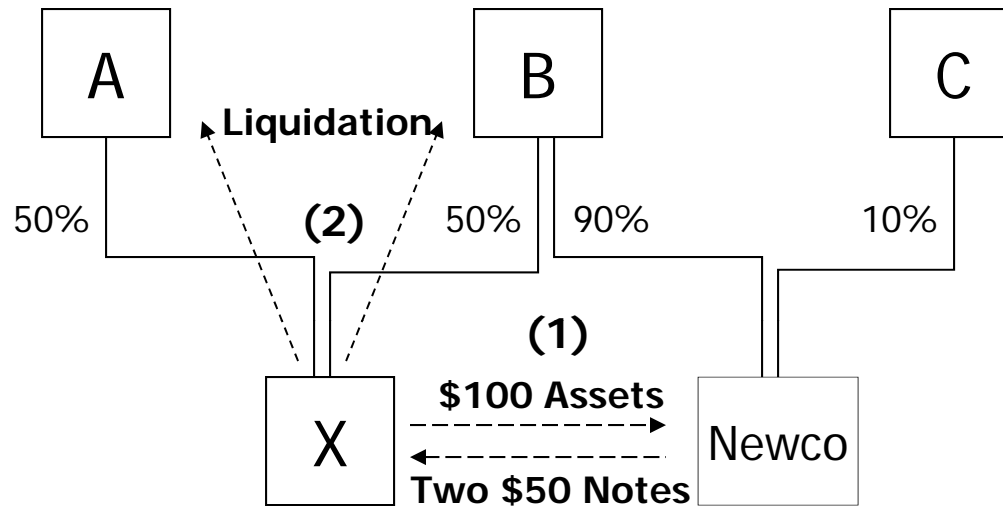

**Facts:** A and B own 50% of the stock of X. B and C own Newco, with B owning 90% and C owning 10% of the stock, respectively. X transfers all \$100 of its assets to Newco in exchange for two \$50 notes. Immediately thereafter, X liquidates, distributing one note to each of A and B.

**Result:** Under the final regulations, there is no shareholder identity and proportionality of ownership in X and Newco and, thus, this transaction does not qualify as a tax-free 'D' reorganization. See Reg. § 1.368-2(1)(3), ex. 6; see also PLR 200551018.



## ‘D’ Reorganization Regulations – Triangular Reorganizations

- The nominal share and deemed stock rules do not apply to triangular reorganizations (i.e., transaction otherwise described in Reg. § 1.358-6(b)(2) or section 368(a)(1)(G) by reason of section 368(a)(2)(D).
- Without such an exception, related-party tax-free triangular reorganizations would be treated as ‘D’ reorganizations with the parent stock being treated as boot.
  - If a transaction is described in both section 368(a)(1)(D) and 368(a)(1)(C), then the ‘D’ characterization trumps the ‘C’ characterization. Section 368(a)(2)(A).
  - In a forward triangular merger, the deemed issuance of a nominal share of acquiring corporation stock would violate the requirement of section 368(a)(2)(D)(i).

# 'D' Reorganization Regulations – Triangular Reorganizations

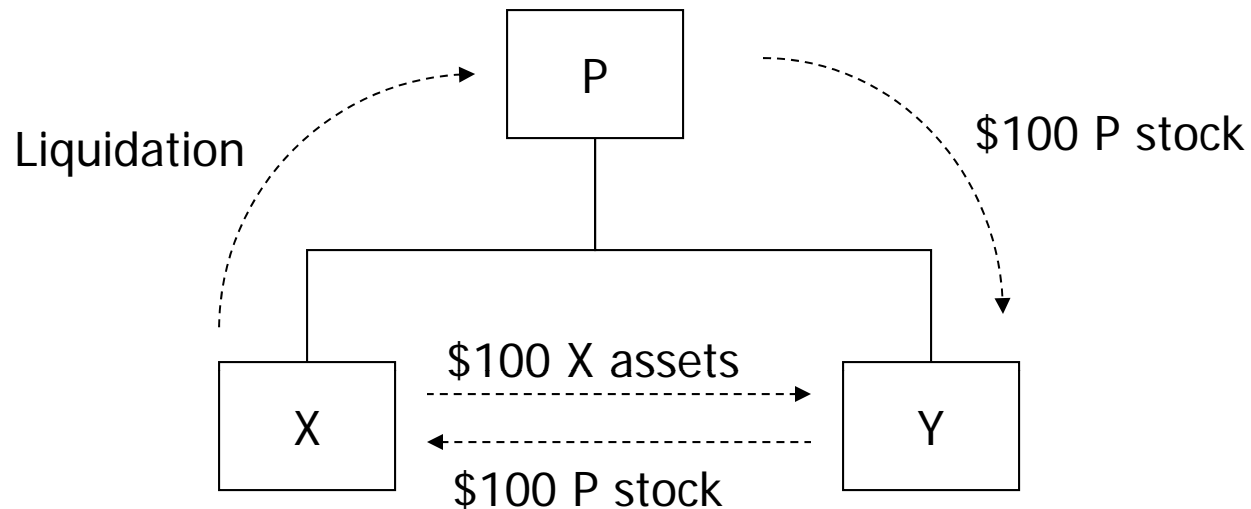

**Facts:** P owns all of the stock of X and Y. X transfers all \$100 of its assets to Y solely in exchange for \$100 worth of P stock and X liquidates.

**Result:** This transaction satisfies the technical requirements of a 'C' reorganization and is not treated as a 'D' reorganization by reason of the nominal share and deemed stock rules. Prior to the March 2007 amendment to the temporary regulations, this transaction could be treated as a valid 'D' reorganization, with the P stock being treated as boot. See section 368(a)(2)(A). The final regulations retain this amendment. See Reg. § 1.368-2(1)(2)(iv).

# Triple Drop and Check – Alternative Characterizations

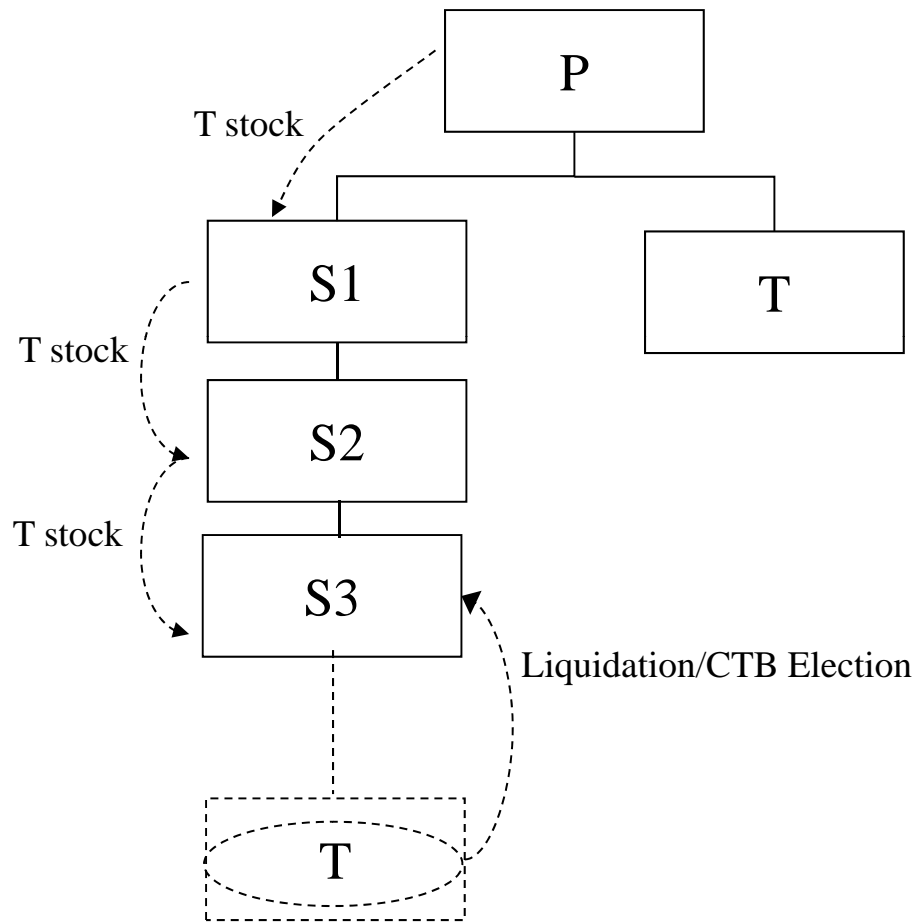

## **Facts:**

- In order to achieve certain business synergies, P desires for the assets of T to be held by S3. Assume that T is solvent.
- P contributes the stock of T to S1, which contributes it down the chain to S3. T then liquidates or is deemed to liquidate by making a check-the-box election.

## **Alternative Characterizations:**

1. Three section 351 contributions followed by a section 332 liquidation.
2. Two section 351 contributions followed by a D reorganization.
3. One section 351 contribution followed by a triangular C reorganization.
4. All-boot D reorganization.

See PLR 201150021 (characterized as option 2)

## ‘D’ Reorganization Regulations – Basis Consequences

- The final regulations did not adopt comments that would treat the nominal share as having tax significance solely to satisfy the distribution requirement in section 354(b)(1)(B). Instead, the final regulations treat the nominal share as qualifying property for purposes of basis allocation and future stock gain or loss recognition.
- Reg. § 1.358-2(a)(2)(iii) provides that if a shareholder or security holder surrenders a share of stock or a security and receives no property or property with a value that is less than the FMV of the stock or securities surrendered:
  - The shareholder or security holder is deemed to receive stock equal to the value of stock or securities actually surrendered;
  - Such stock receives a substituted basis; and
  - There is a deemed recapitalization for the shares actually held by the shareholder or security holder immediately after the reorganization.
- The final regulations clarify that the approach set out in Reg. § 1.358-2(a)(2)(iii) applies to determine the basis consequences in a reorganization in which the property received consists solely of non-qualifying property equal to the value of the assets transferred (as well as the nominal share).
  - The shareholder or security holder may designate the share of stock of the transferee to which basis, if any, of the stock or securities surrendered will attach.
  - Query when this designation must be made—i.e., before or after the deemed transfers of the nominal share.

## 'D' Reorganization Regulations – Basis of Nominal Share

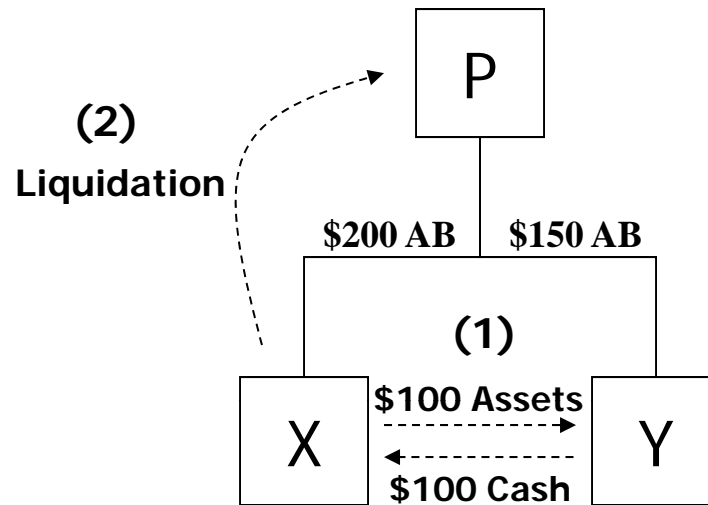

**Facts:** P owns all of the stock of X and Y. P's basis in the X stock is \$200 (100 shares at \$2/share), and P's basis in the Y stock is \$150 (50 shares at \$3/share). X transfers all \$100 of its assets to Y in exchange for \$100 cash and immediately liquidates into S.

**Result:** P's basis in the Y nominal share is \$100 (i.e., \$200 basis in X less \$100 cash received). P is then deemed to recapitalize its Y shares, including the nominal share, into the Y stock P actually owns. P may designate the share(s) of Y stock to which the basis of the nominal share attaches. Assuming P designates the basis as attaching to a single share, P should have 49 shares with a basis of \$3/share and 1 share with a basis of \$103.

What if P owns both common and preferred stock of Y. Can it designate the basis as attaching only to the preferred stock?

## 'D' Reorganization Regulations – Basis of Nominal Share in Lower Tier Subsidiary

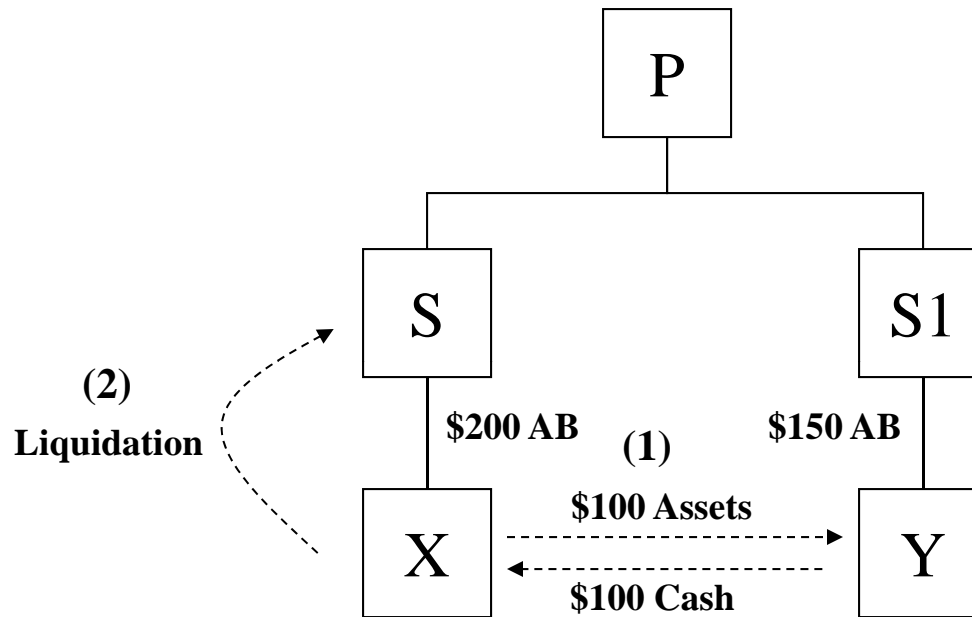

**Facts:** Same facts as the last example, except that P indirectly owns the stock of X and Y through S and S1, respectively.

**Result:** S's basis in the Y nominal share is \$100 (i.e., \$200 basis in X less \$100 cash received). The nominal share of Y stock will be treated as going up to P and back down to S1. Is S's loss on the nominal share disallowed under section 311(a)?

When does the deemed recapitalization occur? Before the deemed distribution by S, or after the nominal share is deemed transferred to S1?

## 'D' Reorganization Regulations – Basis of Deemed Stock in Lower Tier Subsidiary

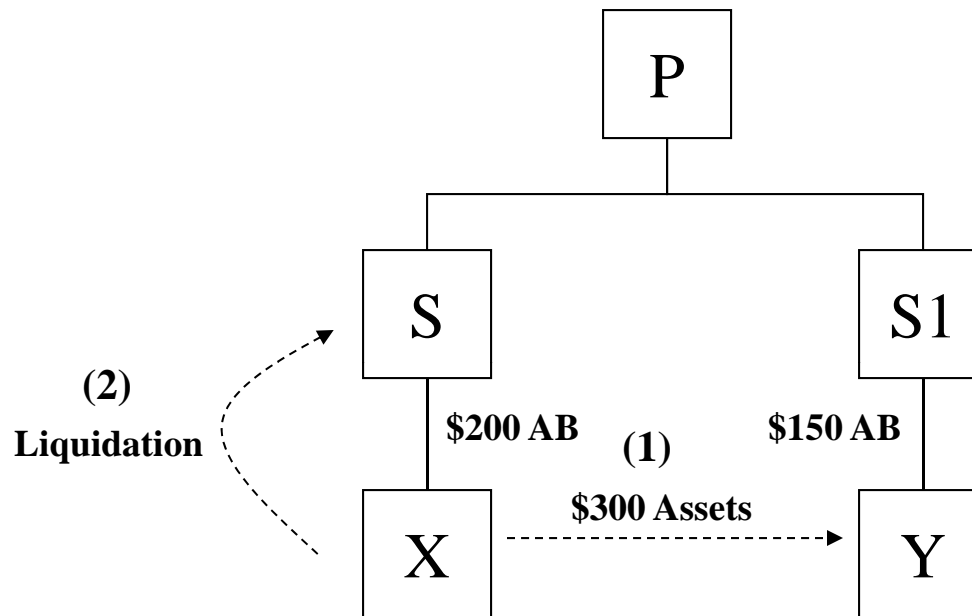

**Facts:** Same facts as the last example, except that X's assets are worth \$300 instead of \$100, and they are transferred to Y for no consideration.

**Result:** The deemed Y stock should have a basis of \$200 and a value of \$300 in S's hands. The deemed Y stock will be treated as going up to P and back down to S1. Is S's gain loss on the deemed stock triggered under section 311(b)?

## 'D' Reorganization Regulations – Consolidated Groups

- The final regulations confirm that the nominal share will be given effect in connection with all-cash 'D' reorganizations involving consolidated return members.
- Under the consolidated return regulations, an all-cash 'D' reorganization involving consolidated return members will result in a deemed issuance of stock by the transferee corporation followed by a redemption of the deemed stock for the consideration actually received in the exchange. See Reg. § 1.1502-13(f)(3).
- The final regulations confirm that, upon the deemed issuance and redemption, the remaining stock basis or excess loss account ("ELA") will shift to the nominal share. Thus, gain or loss inherent in that basis or ELA may be triggered upon the deemed transfer of the nominal share through chains of ownership, subject to the intercompany transaction rules of Reg. § 1.1502-13.



## 'D' Reorganization Regulations – Consolidated Groups

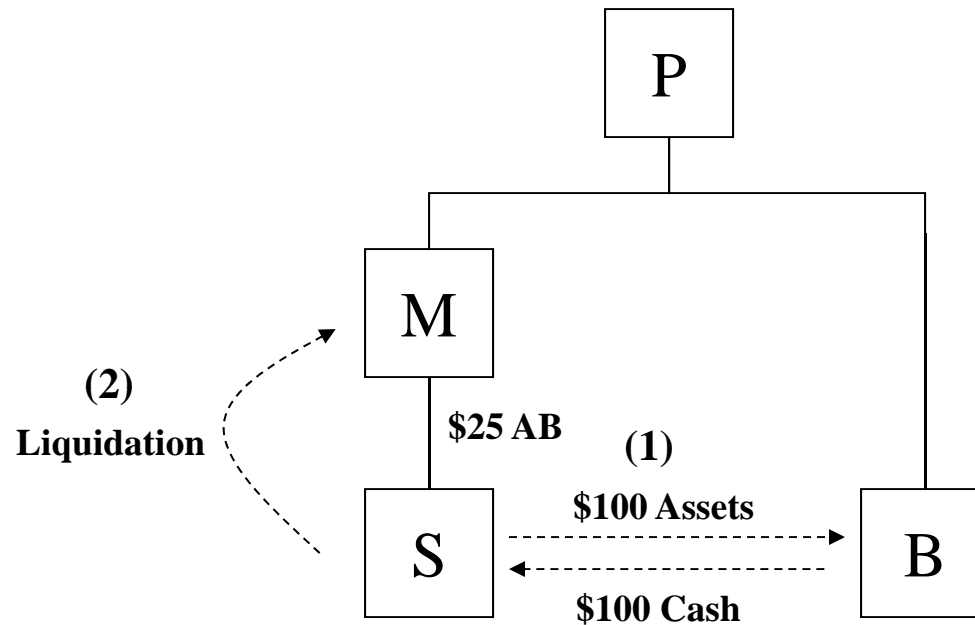

**Facts:** P, M, S, and B file a consolidated return. M's basis in the S stock is \$25. S transfers all \$100 of its assets to B in exchange for \$100 cash and immediately liquidates into M.

**Result:** In the consolidated return context, the following events are deemed to occur: (i) B is treated as issuing \$100 stock plus a nominal share of B stock; (ii) S is treated as distributing B stock to M in liquidation; and (iii) B is treated as redeeming its stock (except for the nominal share) from M for \$100 cash. M's \$25 basis in the B stock is reduced by \$100, resulting in an ELA of \$75, which attaches to the nominal share. M's deemed distribution of the nominal share of B stock to P will trigger the ELA, resulting in intercompany gain of \$75 under section 311(b). See Reg. § 1.1502-13(f) and (f)(7)(i), ex. 4.

What if B actually issued a share of B stock? What if P contributed a share of B stock to M prior to the 'D' reorganization?

Intercompany Asset Sale and Liquidation — “Substantially All”  
Problem or Deemed Downstream Asset Transfer?

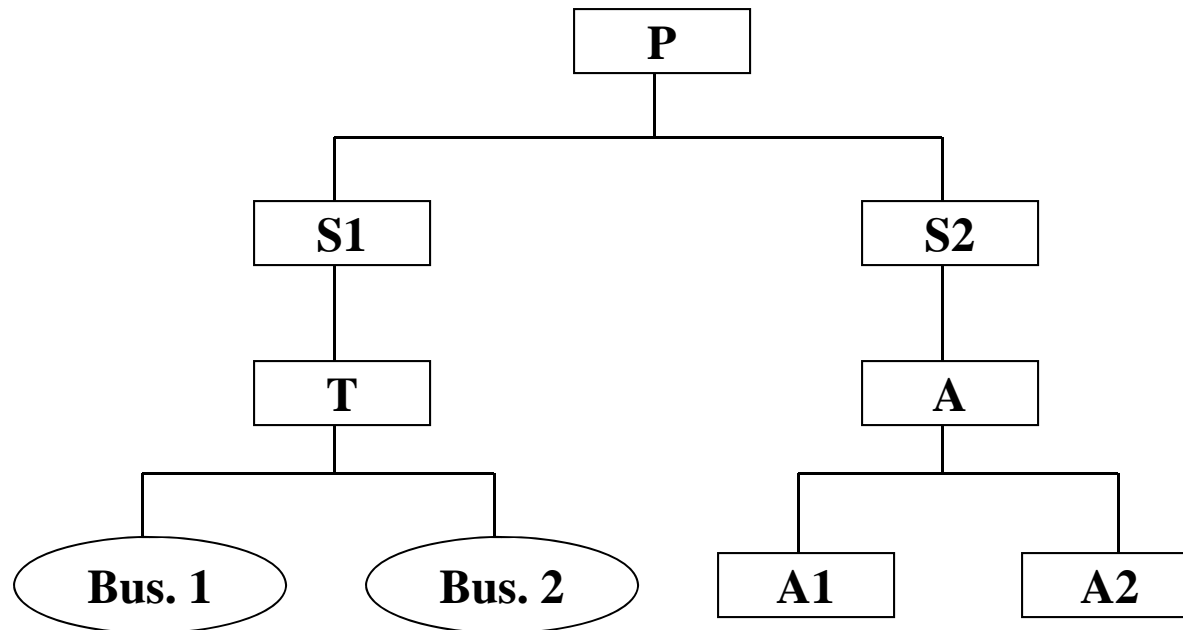

- P owns the stock of S1 and S2.
- S1 owns the stock of T, and T owns Business 1 and Business 2, each with \$500 FMV.
- S2 owns the stock of A, and A owns the stock of A1 and A2.
- T transfers Business 1 to A1 and business 2 to A2, in each case for \$500 cash.
- T is liquidated and distributes the \$1,000 cash to S1.
- Is the transaction an “all-cash D reorganization”?

# PLR 201003012 – ‘D’ and ‘F’ Reorganizations

## Internal Corporate Combination

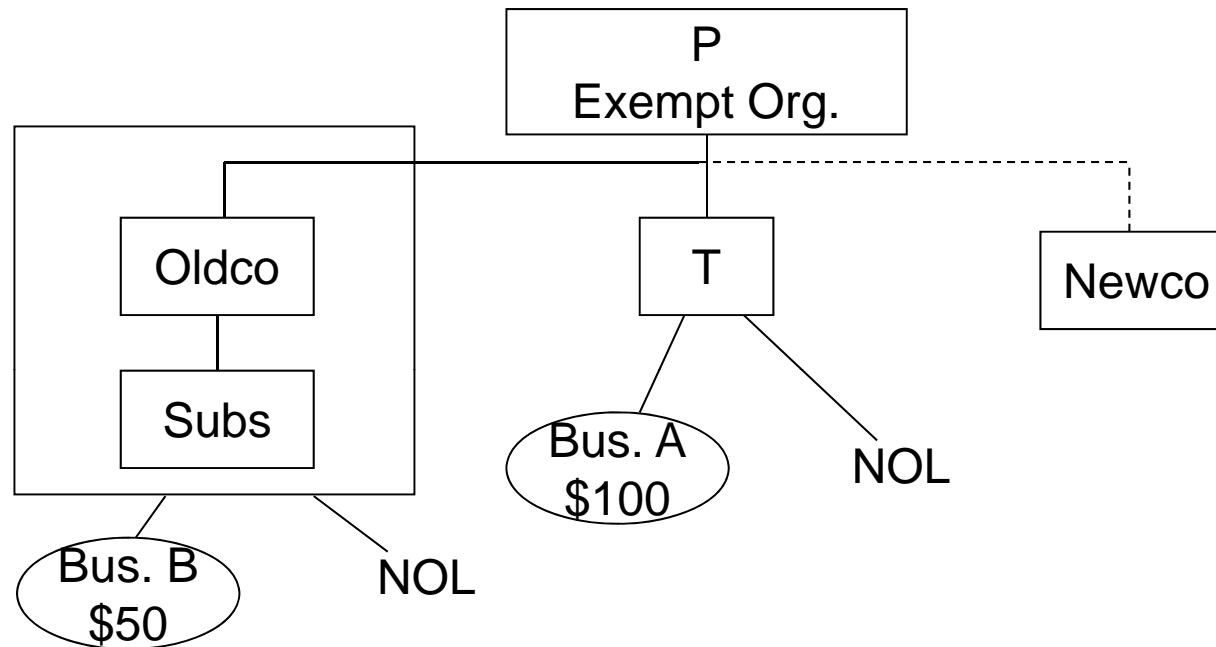

- P forms Newco.
- P contributed the Oldco stock and the T stock to Newco for no consideration.
- Oldco and T each is converted into a limited liability company; no election is made to classify Oldco LLC or T LLC as a corporation for tax purposes.
- Oldco may transfer some assets to JVs or otherwise dispose of assets, but these assets are “not critical” to Oldco’s business, and the dispositions will be “unrelated to and not dependent on” the transactions. Represented that assets disposed of other than in OCB, to JVs or under section 368(a)(2)(C) will be <10%.

## Intercompany Asset Transfer

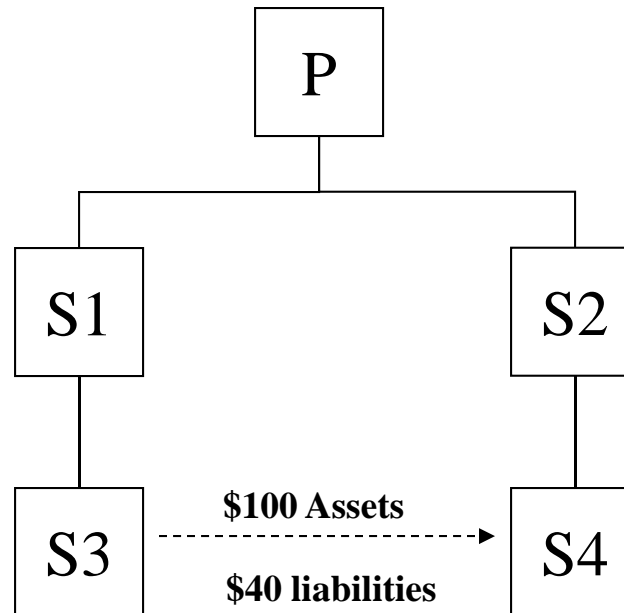

- P owns the stock of S1 and S2. S1 owns the stock of S3. S2 owns the stock of S4. P, S1, S2, S3, and S4 are an affiliated group of corporations that file a consolidated return.
- S3 transfers \$100 Assets to S4. S4 also assumes \$40 of liabilities from S3. S4 does not transfer any additional consideration to S3.
- Do principles similar to those in the “D” reorganization regulations cause section 351 to apply? If so, what are the consequences?

# Check-and-Sell Transaction

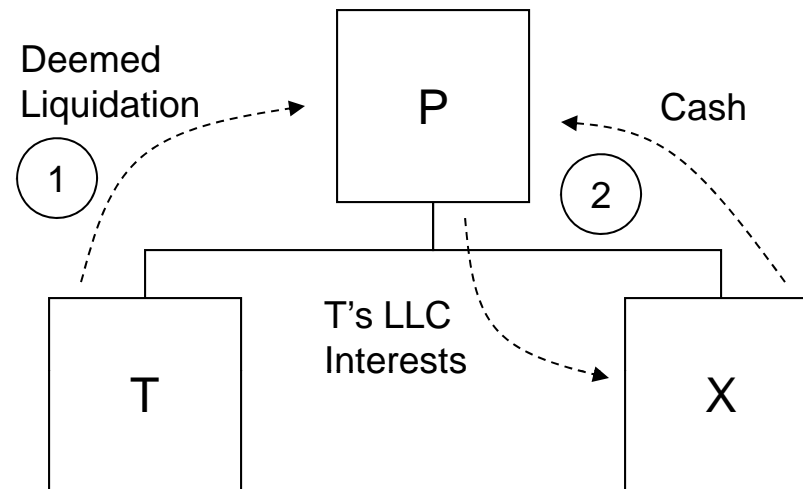

**Facts:** P, T, and X are corporations. P owns all of the stock of T and X. T checks the box to be treated as a disregarded entity and P sells T's LLC interests to X.

**Result:** Is the transfer treated as an asset transfer or a stock transaction? See *Dover Corp. v. Commissioner*, 122 T.C. 324 (2004).

## Check-and-Sell Transaction – Variation

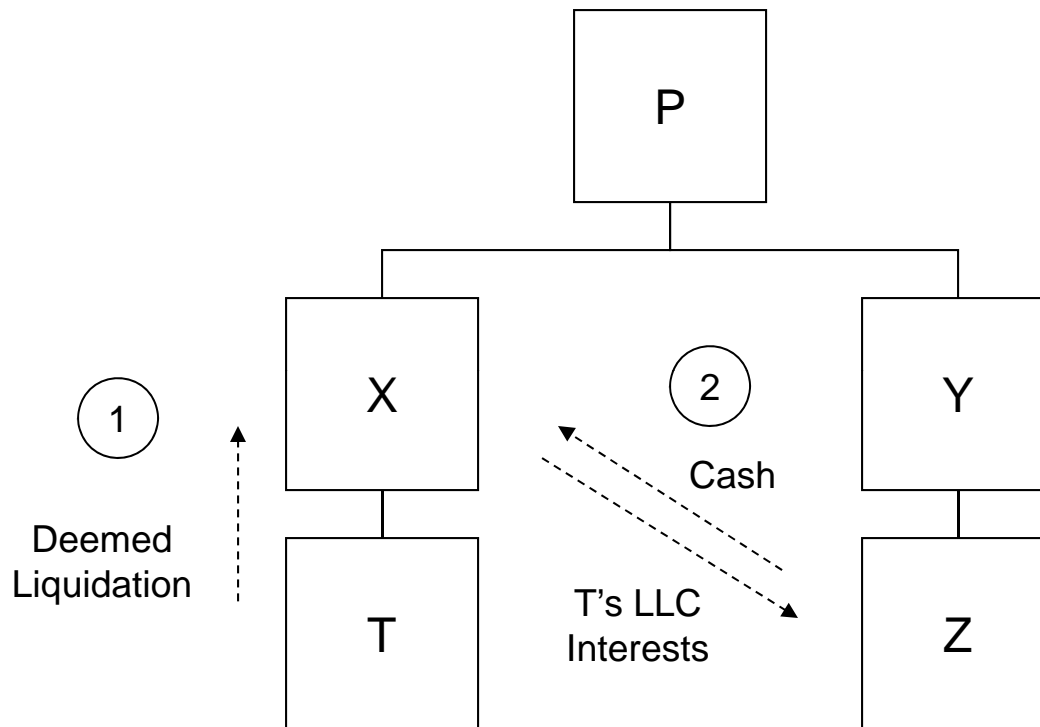

**Facts:** P, X, Y, T and Z are corporations. P owns all of the stock of X and Y, and X and Y own all of the interests in T and Z, respectively. T checks the box to be treated as a disregarded entity and X sells T's LLC interests to Z.

**Result:** Is the transfer treated as a liquidation followed by a sale? See *Dover Corp. v. Commissioner*, 122 T.C. 324 (2004). What result if X sells only part of its LLC interests in T?

# Cross-Chain Section 351 Exchange

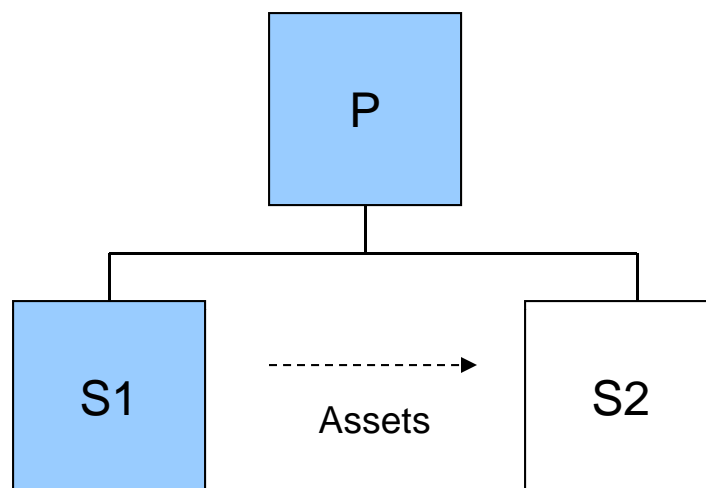

**Facts:** P owns all of the stock of S1 and S2. P and S1 are members of a consolidated group. S2 files a separate return. S1 transfers assets to S2 but does not receive stock or other consideration in exchange. S1 continues its business activities after the transfer of property.

**Result:** To qualify as a section 351 exchange, S1 must transfer property to S2 in exchange for stock and be in control of S2 immediately after the exchange. S1 satisfies the control requirement because it is treated as owning the S2 stock held by P, a member of its consolidated group under the consolidated stock attribution rule of Treas. Reg. § 1.1502-34. However, it is unclear whether S1 can satisfy the exchange requirement because it does not receive S2 stock in the exchange. Consistent with the final regulations on “D” reorganizations, should S2 be deemed to issue stock to S1, with the S2 stock distributed up to P?

Temporary Regulations –  
Allocation of Basis in All Cash “D”  
Reorganizations



# Temporary Regulations on Allocation of Basis in All Cash “D” Reorganizations

- On November 18, 2011, Treasury and the IRS issued temporary regulations to clarify that the ability to designate the share of stock of the issuing corporation to which the basis, if any, of the stock or securities surrendered will attach applies only to a shareholder that owns actual shares in the issuing corporation.
  - The IRS and Treasury stated that they issued the regulations in response to comments that the mechanics of preserving basis in the shares of stock or securities surrendered in the basis of the stock of the issuing corporation were unclear under current law.
- The IRS and Treasury acknowledged the argument that the current rules could be interpreted to allow what they deemed an inappropriate allocation of basis.
  - The rules could be interpreted to allow persons who do not own actual shares of stock of the issuing corporation to allocate the adjusted basis of the nominal share to an actual share of stock of the issuing corporation directly owned by someone else before the nominal share is deemed to be further transferred through the chains of ownership.
  - Under this interpretation, the actual share to which the basis was allocated could be sold to recognize a loss. As a result, a taxpayer would avoid losing the nominal share’s basis, which otherwise could be zero following its deemed transfer through chains of ownership to the actual shareholder of the issuing corporation

# Temporary Regulations on Allocation of Basis in All Cash “D” Reorganizations

- The temporary regulations clarify and amend the final regulations under Treas. Reg. § 1.358-2(a)(2)(iii).
  - If an *actual* shareholder of the issuing (acquiring) corporation is deemed to receive a nominal share of issuing corporation stock as described in Treas. Reg. § 1.368-2(l), the shareholder must, after allocating and adjusting the basis of the nominal share and adjusting the basis in the nominal share for any transfers described in Treas. Reg. 1.368-2(l), designate the share of stock of the issuing corporation to which the basis, if any, of the nominal share will attach.
  - If the shareholder that receives the nominal share is not an *actual* shareholder of the issuing corporation, that shareholder may not designate any particular share to which the basis of the nominal share will attach.
- The temporary regulations apply to exchanges and distributions of stock and securities occurring on or after November 21, 2011.

## Temporary Regulations on Allocation of Basis in All Cash “D” Reorganizations – Acquisition of Lower-Tier Subsidiary by Upper-Tier Subsidiary

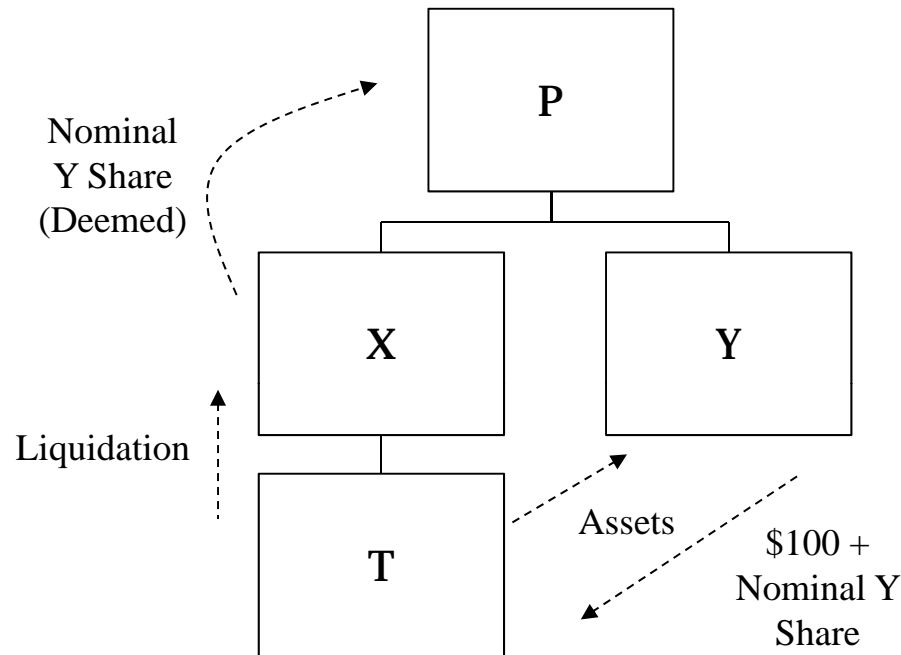

**Facts and All Cash “D” Reorganization Construct:** P owns all the stock of X and Y, and X owns all of the stock of T. X has \$150 basis in its T stock. T sells all of its assets to Y for \$100 cash, their FMV, and liquidates. Under Treas. Reg. § 1.368-2(l), Y is deemed to issue a nominal share of Y stock to T in addition to the \$100, and T is deemed to distribute the nominal share of Y stock to X. Under section 358(a), X will have a \$50 basis in the nominal Y share. X is deemed to distribute the nominal Y share to P. Under section 311(a), X does not recognize the loss on the deemed distribution of the nominal share to P. Under section 301(d), P’s basis in the nominal Y share would be zero, its FMV.

**Prior Law:** Arguably, X may allocate the \$50 basis in the nominal Y share to an actual Y share owned by P.

**Temporary Regulations:** X is deemed to receive the nominal Y share described in Treas. Reg. § 1.368-2(l). However, under Treas. Reg. § 1.358-2T(a)(2)(iii)(C), X is not an actual shareholder of Y, the issuing corporation. Thus, X may not designate any share of Y stock to which the \$50 basis of the nominal Y share will attach. Also, P may not designate a Y share to which basis will attach, because P receives the nominal Y share with a zero basis. Treas. Reg. § 1.358-2T(a)(2)(iii), Ex. 16.

## Temporary Regulations on Allocation of Basis in All Cash “D” Reorganizations – Acquisition of Upper-Tier Subsidiary by Lower-Tier Subsidiary

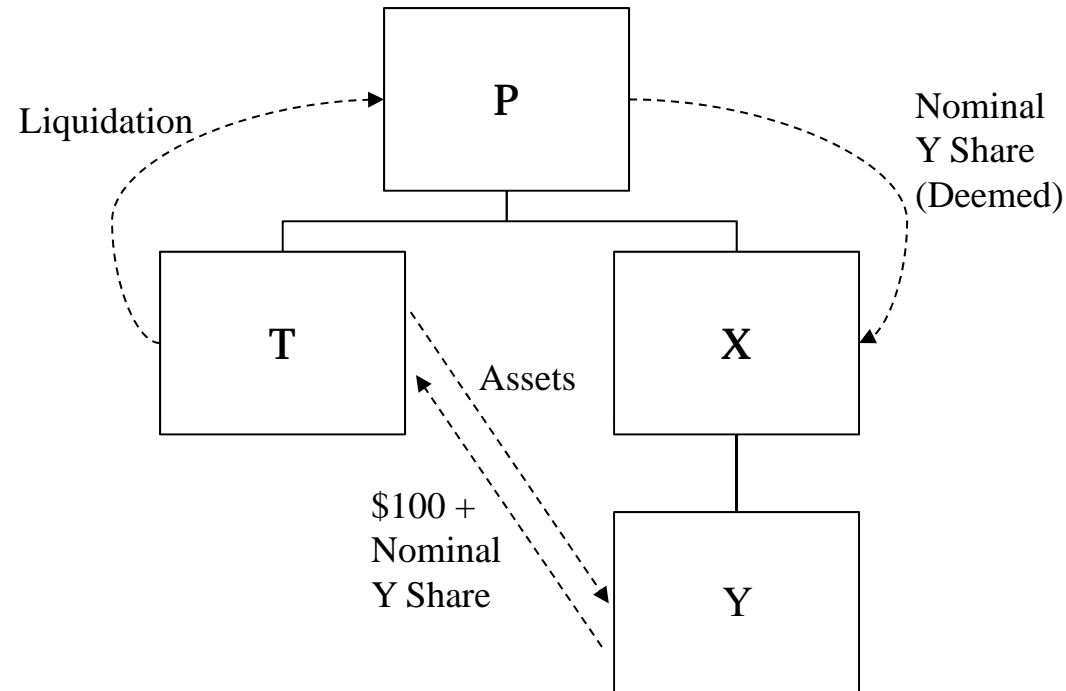

**Facts and All Cash “D” Reorganization Construct:** P owns all the stock of T and X, and X owns all the stock of Y. P has \$150 basis in its T stock. T sells all of its assets to Y for \$100 cash, their FMV, and liquidates. Under Treas. Reg. § 1.368-2(l), Y is deemed to issue a nominal share of Y stock to T in addition to the \$100, and T is deemed to distribute the nominal Y share to P in liquidation. P is deemed to contribute the nominal Y share to X. Under section 358(a), X will have a \$50 basis in the nominal Y share.

**Temporary Regulations:** P is deemed to receive the nominal Y share described in Treas. Reg. § 1.368-2(l). However, under Treas. Reg. § 1.358-2T(a)(2)(iii), P is not an actual shareholder of Y, the issuing corporation. Thus, P may not designate a share of Y or X stock, and X may not designate a share of Y stock, to which the \$50 basis of the nominal Y share will attach.

## Contingent Purchase Price in Taxable Acquisitions

# Contingent Purchase Price in Taxable Acquisitions

## Seller Consequences

- Closed transaction method
- Open transaction method
- Installment method

# Contingent Purchase Price in Taxable Acquisitions

## Seller Consequences

### Discussion Problem—Facts

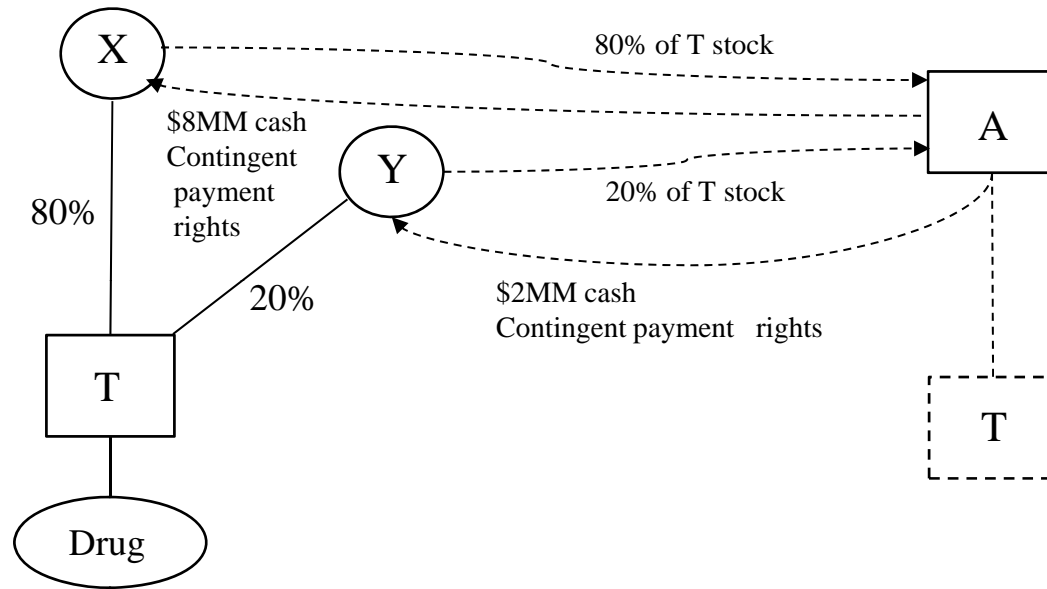

- X has owned 80%, and Y has owned 20%, of the T stock for five years. X's and Y's stock basis = \$0
- T has developed Drug that could cure a dreaded disease, but no clinical trials leading to regulatory approval have been held
- X and Y sell the T stock to P for:
  - \$10 million cash
  - Right to payments up to \$100 million as regulatory landmarks are reached
  - Right to percentage of sales of Drug with no maximum
- In its financial statement, A reports a \$25 million liability for the contingent payments to X and Y

# Contingent Purchase Price in Taxable Acquisitions

## Seller Consequences

### Discussion Problem

### Analysis

- **Closed transaction**
  - Gain taxed at closing = cash received + FMV of contingent payment right
    - A's gain = \$8MM + \$20MM (?). All long-term capital gain
    - B's gain = \$2MM + \$5MM (?). All long-term capital gain
  - Gain or loss on contingent payments
    - Recovery of basis up to FMV taxed at closing
    - Gain to extent contingent payments received > FMV taxed at closing — probably ordinary income
    - Loss to extent payments received < FMV taxed at closing — probably ordinary loss
    - Imputed interest taxed as ordinary income as cash received
- **Open transaction**
  - Gain taxed at closing = cash received; all long-term capital gain
  - Gain on contingent payments taxed as received; all long-term capital gain except imputed interest
- **Installment method**
  - Gain taxed at closing = cash received; all long-term capital gain
  - Gain on contingent payments taxed as received; all long-term capital gain except imputed interest
  - Section 453A deferral charge on deferred gain >\$5MM
  - How is “deferred gain” determined?
- *See also* §1202



**Contingent Purchase Price in Taxable Acquisitions**  
**Seller Consequences**  
**Closed Transaction Method**  
**Treatment at Closing**

- Reg. §1.1001-1(g)(2)
  - Amount realized on sale includes FMV of contingent payment right
  - In determining FMV, restrictions on transfer of payment right are not taken into account
  - FMV of contingent payment right cannot be < FMV of property sold, less other amounts realized
  - Taxable at closing of sale
- Old case law suggested that cash method Seller could defer tax until receipt of “cash equivalent,” but regs reject this case law
  - *Warren Jones Co. v. Commissioner*, 524 F.2d 788 (9<sup>th</sup> Cir. 1975), *rev’g* 60 T.C. 663 (1973)
  - Reg. §15a.451-1(d)(2)(i)

**Contingent Purchase Price in Taxable Acquisitions**  
**Seller Consequences**  
**Closed Transaction Method**  
**Gain or Loss on Receipt of Contingent Payment**

- Each payment is treated as part-principal and part-interest, if adequate interest is not stated (§483 or §1274; Reg. §§1.483-4 and 1.1275-4(c)(4))
  - In most acquisitions, interest portion of payment is ordinary income to Seller and deductible to Buyer, but only when contingency is fixed
  - No OID or other interest income accrual before contingency is fixed
  - Principal first goes to recover basis of contingent payment right (FMV included in amount realized at closing)
  - Excess of principal payments received over basis of contingent payment right = gain
  - Excess of basis in contingent payment right over principal payments received = loss, but loss may be taken only when no more contingent payments are expected
- Character of gain or loss
  - Character of gain or loss on sale to may govern character on contingent payment right (*Arrowsmith v. Commissioner*, 344 U.S. 900 (1952))
  - If *Arrowsmith* does not govern, character is uncertain and may depend on whether contingent payment right is a “debt instrument” or a “contract right”

**Contingent Purchase Price in Taxable Acquisitions**  
**Seller Consequences**  
**Closed Transaction Method**  
**Character of Gain or Loss**  
**Debt Instrument or Contract Right?**

- In a number of cases, courts have tried to determine—
  - If a contract right to receive ordinary income (*e.g.*, winning lottery ticket, real property lease by owner, right to sell or purchase electric power) is a capital asset, resulting in capital gain or loss on sale
  - If a transaction in which a contract right holder is paid under the contract or in settlement thereof is “sale or exchange” resulting in capital gain or loss
- Section 1234A may allow capital gain and require loss
  - Is payment received under terms of contract a payment in “cancellation, lapse, expiration or other termination” of contract?
  - Case for capital gain or loss under §1234A is weakened where contract calls for stream of payments, not a single payment (unless right to each payment is treated as a separate contract)

**Contingent Purchase Price in Taxable Acquisitions**  
**Seller Consequences**  
**Closed Transaction Method**  
**Character of Gain or Loss**  
**if Debt Instrument**

- Section 1271(a) imposes exchange treatment at maturity, overruling *Fairbanks v. United States*, 306 U.S. 436 (1939)
- This treatment would produce capital gain or loss
- “Debt instrument” broadly defined in §1275 regulations
- But uncertainty remains under debt vs. contract case law, where right to future payments is contingent on future events

**Contingent Purchase Price in Taxable Acquisitions**  
**Seller Consequences**  
**Closed Transaction Method**  
**FMV of Contingent Payment Rights Underestimated**  
**Character of Gain**

- What happens if little is expected but much is received from contingent payment right?
- Possible conversion of contingent sale price from capital gain to ordinary income
  - Contingent payment right is determined to be contract right, not debt instrument
  - *Arrowsmith v. Commissioner*, 344 U.S. 900 (1952) does not govern

**Contingent Purchase Price in Taxable Acquisitions**  
**Seller Consequences**  
**Closed Transaction Method**  
**FMV of Contingent Payment Rights Overestimated**  
**Character of Loss**

- What happens if much is expected but little or nothing is received from the contingent payment right?
- If gain from an underestimated FMV of contingent payment right would be ordinary income, loss from overestimated FMV should be ordinary loss
- If the loss is a capital loss, the loss can be orphaned if capital gains are not available:
  - Gain recognized on the sale may not be available from loss carryback
  - If Seller is an individual, no carryback
  - If Seller is a C corporation, 3-year carryback

**Contingent Purchase Price in Taxable Acquisitions**  
**Seller Consequences**  
**Open Transaction Method**  
**General**

- Based on *Burnet v. Logan*, 283 U.S. 404 (1931); *see also Inaja Land Co. v. Commissioner*, 9 T.C. 727 (1947), *acq.* 1948-1 C.B. 2
- Available only in “rare and extraordinary” cases where FMV of contingent payment right is not reasonably ascertainable (Reg. §1.1001-2(g)(2)(ii))
- Compare *Dorsey v. Commissioner*, 49 T.C. 606 (1968) and *MacDonald v. Commissioner*, 55 T.C. 840 (1971) (open transaction method allowed) with *In re Steen v. United States*, 509 F.2d 1398 (9<sup>th</sup> Cir. 1975) (open transaction method partially allowed)

**Contingent Purchase Price in Taxable Acquisitions**  
**Seller Consequences**  
**Open Transaction Method**  
**Comparison with Other Methods**

- Advantages compared with installment method:
  - o Full front-end asset basis recovery
  - o No §453A deferral charge
- Compared with closed transaction method:
  - o Advantage: All proceeds, other than imputed interest, eligible for capital gain treatment
  - o Disadvantage: No loss until remaining basis exceeds possible remaining payments



**Contingent Purchase Price in Taxable Acquisitions**  
**Seller Consequences**  
**Open Transaction Method**  
**Recent Support**

- Despite hostility in the regulations and recent commentary, the open transaction method is still available in some situations
- Recent court decisions are surprisingly supportive:
  - *Fisher v. United States*, 82 Ct. Fed. Cl. 780, 102 AFTR 2d 2008-5608 (Aug. 6, 2008), *aff'd without opinion*, 2009 WL 3241381 (Fed. Cir. 2009) (in life insurance company demutualization, policyholders who received cash in lieu of stock entitled to allocate *all* premium costs to basis in stock, on open transaction theory)
  - *Anschutz Company v. Commissioner*, 135 T.C. 78 (2010), *aff'd* 108 AFTR 2d 2011-7590 (10<sup>th</sup> Cir. 2011) (Tax Court allows open transaction treatment for contingent purchase price in complex financial transaction treated as sale)

**Contingent Purchase Price in Taxable Acquisitions**  
**Seller Consequences**  
**Installment Sale**  
**General**

- Defers tax on gain from future payments until received
- Applies only to gain, not loss
- General rule is *pro rata* basis recovery
- If there is a maximum selling price, recover basis on assumption that maximum price will be received
- If there is no maximum selling price, but there is a time limitation, recover basis straight-line over maximum time for payments
- If there is neither maximum selling price nor time limitation—
  - o Basis recovery is straight-line over 15 years unless general rule would inappropriately accelerate basis recovery:
    - Seller may request PLR
    - IRS may require basis recovery on non-straight-line basis
  - o Losses are deferred until all amounts have been recovered
  - o Is the transaction really a sale?
- Each payment is treated as part-principal and part-interest. *See Slide 6*

**Contingent Purchase Price in Taxable Acquisitions**  
**Seller Consequences**  
**Installment Method**  
**Limitations**

- Applies only to gain, not loss
- Not available for—
  - Sale of inventory property (including bulk sale)
  - Sale of marketable securities
  - Depreciation recapture
- Limited security on installment obligation allowed without ending deferral
- Sale to related party followed by second sale within 2 years ends deferral
- Disposition of installment obligation by holder ends deferral
- Modification of installment note may constitute a disposition, but some modifications are permitted.

## Contingent Purchase Price in Taxable Acquisitions

### Seller Consequences

#### Installment Sale

#### Multiple Assets—Allocation of Cash and Installment Obligation

- In sale of multiple assets, can installment obligation be allocated in kind to low-basis assets and cash to high-basis assets?
  - Results: accelerate basis recovery, defer more gain and accelerate loss on some assets
  - Similarly, can different installment obligations be allocated to different assets, each with its own “gross profit ratio”?
  - *Williams v. McGowan*, 152 F.2d 570 (2d Cir. 1945); *Monaghan v. Commissioner*, 40 T.C. 680 (1963), *acq.* 1964-2 C.B. 6; Rev. Rul. 68-13, 1968-1 C.B. 195
  - In LAFAs 20080101F, LB&I concluded that the above authorities apply only to determine character of gain or loss and exclude assets not eligible for installment method (*e.g.*, inventory)—not to thwart ratable basis allocation or allow immediate loss and deferred gain
  - Compatibility of in-kind allocation of consideration with §§1060 and 338(h)(10)?

**Contingent Purchase Price in Taxable Acquisitions**  
**Seller Consequences**  
**Installment Sale**  
**Allocation to Services or Covenants**

- May contingent purchase price be allocated to services provided by Seller or to Seller's covenant not to compete?
- Payment for services—
  - Taxed to Seller on accrual or receipt (cash method) with no basis offset and no deferral charge
  - Usually currently deductible to Buyer as accrued or paid, but deferred compensation rules (§§404(a)(5) and 409A) may defer deduction
- Payment for covenant—
  - Taxed to Seller on accrual or receipt with no basis offset and no deferral charge
  - Amortizable to Buyer under §197

**Contingent Purchase Price in Taxable Acquisitions**  
**Seller Consequences**  
**Installment Sale**  
**Deferral Charge—Computation, Etc.**

- Section 453A imposes a charge for deferring taxable gain under installment method
- Computation:
  - Amount of deferred gain = tax at “maximum rate” on capital gain
    - “Maximum” §1(h) rate for individuals is the 28% rate on sales of collectibles, etc., even though 15% is probably the effective rate on the gain from the sale
    - §1201 determines maximum rate for C corporations
  - Interest rate is the floating underpayment rate
- Deferral charge is treated as interest (§453A(c)(5))
  - Deductible to corporations
  - Not deductible to individuals
- Seller generally may not elect to pay deferred tax early and avoid further deferral charges
  - Installment method has no provision to elect out later, *e.g.*, if interest rates increase (Reg. §15a.453-1(d)(3)(ii))
  - Seller may be able to avoid deferral charges by self-help—disposition (sale or pledge) of installment obligation triggers gain on installment sale
    - Modification of installment note not necessarily a disposition (Rev. Rul.75-457; PLR 201144005)

**Contingent Purchase Price in Taxable Acquisitions**  
**Seller Consequences**  
**Installment Sale**  
**Deferral Charge—*De Minimis* Amounts**

- Deferral charge applies only to—
  - Installment sales of property > \$150,000 sale price
  - > \$5MM aggregate face amount of installment obligations held by Seller at year end (excluding obligations subject to \$150,000 exclusion)
- *De minimis* amounts apply separately to each partner or S corporation shareholder (Notice 88-81, 1988-2 C.B. 397)

**Contingent Purchase Price in Taxable Acquisitions**  
**Seller Consequences**  
**Installment Sale**  
**Deferral Charge—Contingent Payments—General**

- Regulations are to be issued on application of §453A to contingent payments (§453A(c)(6)), but no regulations have been issued or proposed
- Can §453A be ignored until regulations become effective?
  - Many contingent obligations do not have a “face amount,” and so *de minimis* rule may apply (or there may be no “installment obligation”)
  - FSA 199941001 (§453A self-executing without regulations)



## **Contingent Purchase Price in Taxable Acquisitions**

### **Seller Consequences**

#### **Installment Sale**

#### **Deferral Charge—Contingent Payments—Possible Computation Methods**

- Until §453(c)(6) regs become effective, how is deferral charge computed?
  - FSA 199941001 (deferral charge based on FMV of contingent payment right at closing)
  - TAM 9853002 (no refund of deferral charge based on FMV of contingent payment right at closing, even if contingent payment is never received)
  - If FMV of contingent payment right cannot be determined at closing, is there no deferral charge, even if Seller does not elect out of installment method?
- LAFA 20080101F suggests another method called “look back”
  - Look back method is not described
  - Would Seller pay deferral charge on contingent purchase price when received, regardless of FMV of contingent payment right at closing?

**Contingent Purchase Price in Taxable Acquisitions**  
**Seller Consequences**  
**Installment Sale**  
**Election Out—General**

- Seller may elect out by reporting sale under either of the other methods:
  - Closed transaction
  - Open transaction
- Does assumption of contingent obligations alone put Seller on installment method unless Seller elects out?
  - Election out of installment method is irrevocable except with IRS consent
  - Seller may not elect out after filing original return except for good cause with IRS consent, to be granted in “rare circumstances” (Reg. §15a.453-1(d)(3)(ii))

**Contingent Purchase Price in Taxable Acquisitions**  
**Seller Consequences**  
**Installment Sale**  
**Election Out—Erroneous Open Transaction Method**

- Consequences of electing out of installment method to claim open transaction method and being wrong:
  - Because of election out, no deferral charge
  - Regulations do not allow late revocation of election out
  - Result is closed transaction method
  - Capital gain character of contingent payments in excess of FMV at closing is jeopardized
- *But see Mamula v. Commissioner*, 346 F.2d 1016 (9th Cir. 1965)
  - Taxpayer erroneously used open transaction method for fixed-amount note on accountant's advice
  - IRS disallowed open transaction method, and taxpayer tried to elect installment method after the fact, but IRS disallowed the election
  - Held, IRS could not refuse to allow taxpayer to elect installment method (distinguishing *Pacific National Co. v. Welch*, 304 U.S. 191 (1938), in which original method was permissible)
  - Does IRS get to choose new method if taxpayer has selected impermissible method?

# Contingent Purchase Price in Taxable Acquisitions

## Buyer Consequences

### Discussion Problem

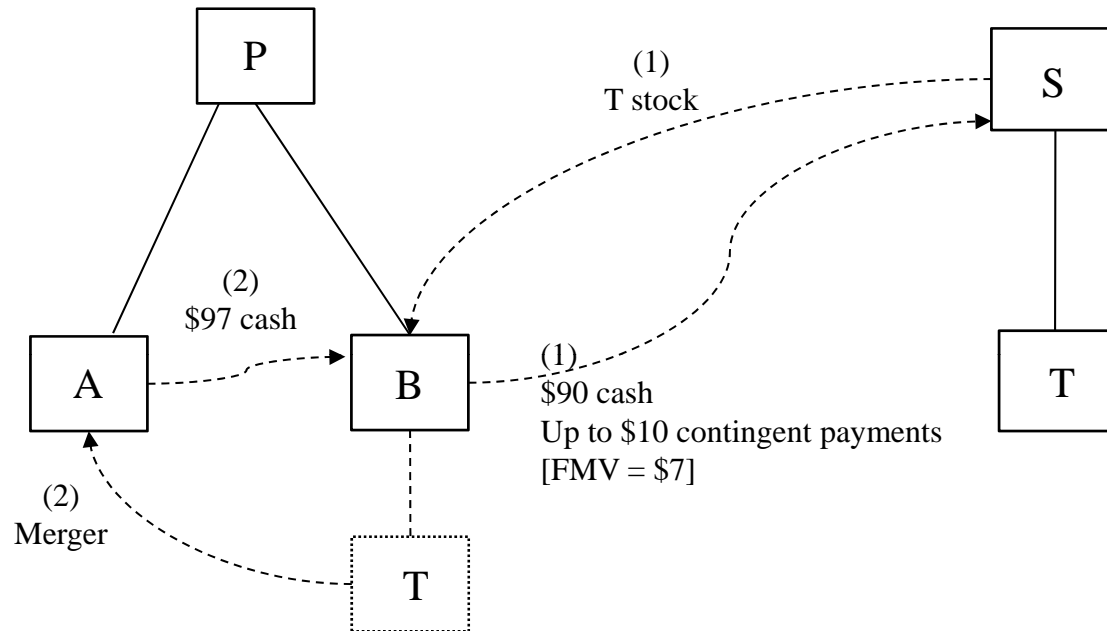

- B buys the T stock from S for \$90 cash and a right to contingent payments up to \$10 (FMV = \$7)
- B's basis in T stock = \$90.
- T is merged into A in an all-cash D reorganization (Reg. §1.368-2(1))
- Consequence to B is \$97 "boot," taxable to the extent of B's \$7 realized gain on the T stock
- What happens if B pays \$7 of contingent purchase price to S after the year of closing? \$10?

# Contingent Purchase Price in Taxable Acquisitions

## Buyer Consequences

- Buyer gets no asset basis for contingent purchase price until fixed or paid
- Makes no difference which method Seller uses to report sale—even if Seller reports difference between amount realized at closing and amount collected as gain or loss in separate transaction (and so does not adjust its §1060 allocation)
- As Buyer pays contingent purchase price, asset basis is increased—usually increases basis in §197 assets

## Escrows in Taxable Acquisitions

## **Escrows in Taxable Acquisitions Issues**

- Is Seller deemed to receive escrowed proceeds upon establishment of escrow at closing (installment sale, closed transaction or open transaction)?
- Who is taxed on income earned by the escrowed funds during the escrow period?

## **Escrows in Taxable Acquisitions**

### **Timing of Inclusion in Seller's Amount Realized**

- If escrow protects Seller (*e.g.*, to secure Buyer's payment of purchase price), Seller is deemed to receive escrow proceeds in year of sale
- If escrow is under Seller control (*e.g.*, investment authority), Seller's amount realized includes escrowed funds
  - *Chaplin v. Commissioner*, 136 F.2d 298 (9th Cir. 1943)
  - *Bonham v. Commissioner*, 89 F.2d 725 (8th Cir. 1937)
- If escrow protects Buyer (*e.g.*, to secure Seller indemnities), amount realized for escrow proceeds is deferred until payment to Seller becomes fixed
  - IRS agrees that sale with escrow for Buyer's benefit is eligible for installment method (Rev. Rul. 77-294, 1977-2 C.B. 173, *amplified* Rev. Rul. 79-91, 1979-1 C.B. 179; IRS Pub. 537 (citing "substantial restriction" requirement); PLR 200521007)
  - Case law supports contrary argument (*Granneman v. United States*, 649 F. Supp. 949 (E.D. Mo. 1986) (note intended to be paid by Buyer, not out of escrow))
  - Section 453A deferral charge applies if installment method is used
  - If escrow with "substantial restrictions" can be reported on open transaction method, §453A does not apply



# Escrows in Taxable Acquisitions

## Taxation of Escrow Income

- “Homeless income”
- Congressional response: §468B(g)(1)
- 1999 proposed regulations would tax *Buyer* on the income from escrowed funds until Seller’s right to the funds becomes fixed
- Until regulations are finalized, either Buyer or Seller may be allocated the escrowed income by contract (Query: Must this allocation have economic substance?)
- Parties’ agreement as to which party reports income does not impact timing of Seller’s gain recognition on sale, or vice versa (Prop. Reg. §1.468B-8(d); *Anderson v. Commissioner*, 20 T.C.M. 697 (1961))

Contingent Obligations in  
Taxable Asset Acquisitions

## Assumption of Contingent Obligations in Taxable Asset Acquisitions — Discussion Problem

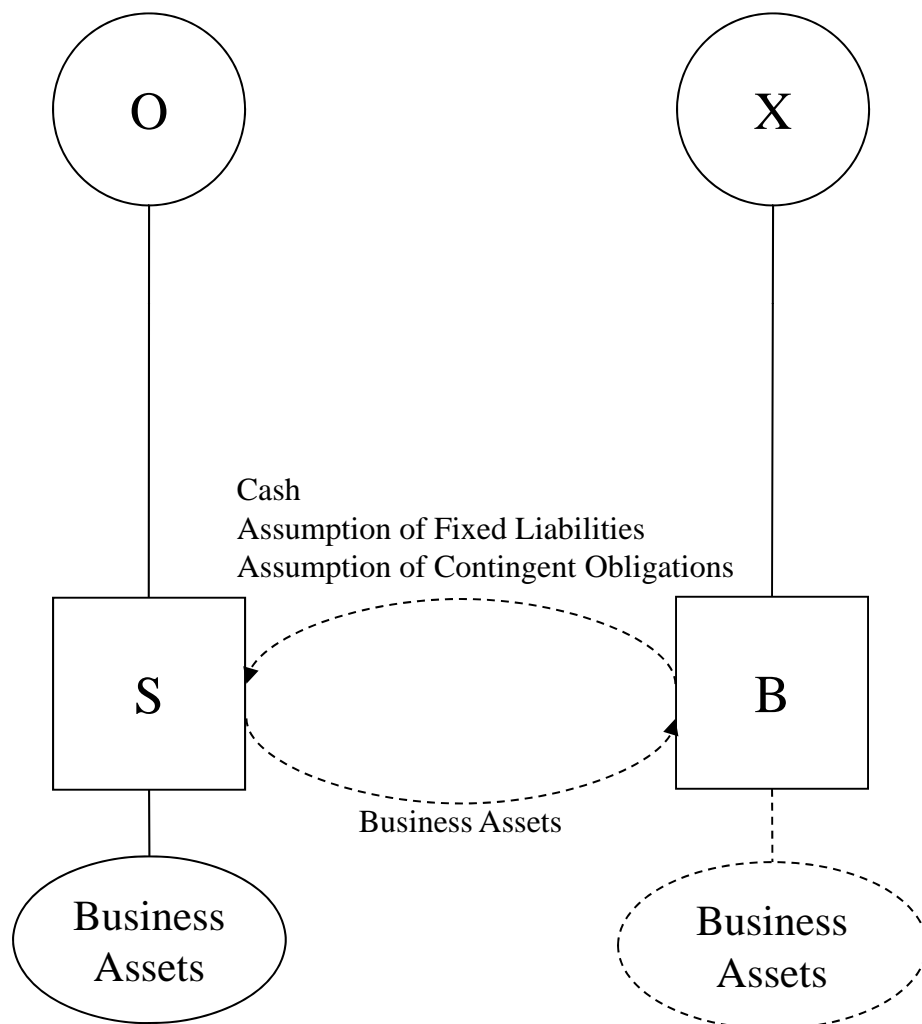

- **Year 1:** B buys Business Assets from S
- B pays cash and assumes S's fixed liabilities and contingent obligations
- S's contingent obligations include:
  - Vested and non-vested deferred compensation to employees
  - Medical benefits to retirees
  - Product warranty and product liability claims (no claim pending)
  - EPA examination of waste sites but no clean-up or payment yet required
  - Pending lawsuit for patent infringement
  - Fixed-price contracts to buy commodities, some at higher, and others at lower than market prices
- Disposition of contingent obligations:
  - **Years 2-4:** B pays deferred compensation, some vested before and some after the acquisition
  - **Each year:** B pays medical benefits to retirees
  - **Each year:** B pays warranty claims in amounts less (or more) than expected
  - **Year 5:** B pays for clean-up of S's waste site
  - **Year 6:** B pays an unexpected judgment in the patent case
  - **Years 1-6:** B complies with all fixed-price contracts

## **Assumption of Contingent Obligations in Taxable Asset Acquisitions Possible Tax Treatments**

- Almost every acquisition involves contingent obligations of the acquired business
  - Environmental obligations
  - Tort liabilities
  - Warranty claims
  - Retiree medical expenses
- Issue arises when Buyer business assets and then pays or incurs a liability attributable to acquired business
- Three tax treatments possible
  - Buyer expense, usually deductible by Buyer when paid or accrued
  - Seller contingent obligation assumed, *i.e.*, Seller expense paid by Buyer
    - Capitalized by Buyer in price paid for purchased assets
    - Added to Seller's amount realized on sale, with offsetting deduction
  - "Fee" analysis

**Assumption of Contingent Obligations  
in Taxable Asset Acquisitions  
Consequences  
Buyer Expense Treatment**

- Buyer “steps into shoes” of Seller and deducts or capitalizes obligation
- Deduction or asset basis increase occurs when obligation is accrued or paid (economic performance) under general tax accounting rules
- No gain, income or deduction to Seller

**Assumption of Contingent Obligations  
in Taxable Asset Acquisitions  
Consequences  
Assumed Contingent Liability Treatment  
General**

**Seller**

- Inclusion in amount realized on sale
- Offsetting deduction
- Imputed interest income
- Installment reporting

**Buyer**

- Capitalize payment but only when accrued and economic performance occurs
- Imputed interest expense

**Assumption of Contingent Obligations  
in Taxable Asset Acquisitions  
Consequences  
Assumed Contingent Liability Treatment  
Seller**

**Inclusion in Amount Realized**

- Seller is relieved of an obligation
- Seller's amount realized is increased
  - One approach is to value the obligation at closing and increase the amount realized at closing by that amount, with adjustments later ("closed transaction")
  - Other approach is to increase amount realized only when contingency becomes fixed and determinable ("open transaction")

**Is Interest Imputed on Deemed Payment?**

- This issue should only apply to open transaction approach
- Arguably there is no imputed interest, because §1274 does not apply to assumed debt (§1274(c)(4))
- Does § 483 require imputed interest upon payment?

**Installment Reporting**

- If open transaction approach is taken, is sale an installment sale because of possible future payment?
  - Section 453 regulations do not discuss assumption of contingent obligations
  - If payment of obligation is treated as payment of purchase price, sale literally falls within definition of contingent payment installment sale
  - Could lead to deferral charge

**Assumption of Contingent Obligations  
in Taxable Asset Acquisitions  
Consequences  
Assumed Contingent Liability Treatment  
Seller (Continued)**

**Does Seller get offsetting deduction against amount realized?**

- Seller should get a deduction (*Commercial Security Bank v. Commissioner*, 77 T.C. 145 (1981))
  - Court said that obligation assumed by Buyer reduced cash received by Seller
  - Such reduction in cash received treated as if Seller actually paid the obligation
  - Seller gets a deduction to offset income



**Assumption of Contingent Obligations  
in Taxable Asset Acquisitions  
Consequences  
Assumed Contingent Liability Treatment  
Seller (Continued)**

**When does Seller get offsetting deduction against amount realized (continued)?**

- Reg. §1.461-4(d)(5) provides that, in a sale of a business, if Buyer “expressly assumes” a fixed liability, economic performance occurs as the liability is included in Seller’s amount realized
- Regulation is too narrow
  - It requires an express assumption
  - It covers only the economic performance requirement, not the all-events test
    - It requires an express assumption
    - It covers only the economic performance requirement, not the all-events test
  - Treas. Reg. §1.461-4(j) reserves treatment of contingent obligations
- If the regulation test is failed, Seller may have income with no matching deduction until later
  - Presumably deduction is deferred until Buyer makes payment, or amount is fixed
  - This is the wrong answer—in acquisition context Seller should not be subject to economic performance
    - §461(h) was intended to prevent premature accrual. If Seller has income recognition, accrual is not premature
    - If Seller does not get deduction at closing, no clear reflection of income
    - Does *Commercial Security Bank* apply if §461(h) requirements are not met?

**Assumption of Contingent Obligations  
in Taxable Asset Acquisitions  
Consequences  
Assumed Contingent Liability Treatment  
Seller (Continued)**

**When does Seller get offsetting deduction against amount realized  
(continued)?**

- Similar problem arises where obligation is to pay nonqualifying deferred compensation
  - Section 404(a)(5) – employer gets deduction when employee has income
  - IRS position: deemed payment found in *Commercial Security Bank*, etc. does not support a deduction until income to employee (TAM 8939002)

**Assumption of Contingent Obligations  
in Taxable Asset Acquisitions  
Consequences  
Assumed Contingent Liability Treatment  
Buyer**

- Treat assumed obligation as cost of purchased assets and add to asset basis
- Capitalization approach has greater support in case law
  - *Webb v. Commissioner*, 77 T.C. 1134 (1981), *aff'd*, 708 F.2d 1254 (7<sup>th</sup> Cir. 1983)
    - Unfunded pension obligation assumed in asset acquisition
    - Payments treated as cost of acquired assets
  - *Holdcroft Transportation Co. v. Commissioner*, 153 F.2d 323 (8<sup>th</sup> Cir. 1946), *Pacific Transport*; *M. Buten & Sons v. Commissioner*, T.C. Memo 1972-44
- Uncertain whether Buyer may treat a portion of the payments as currently-deductible interest when made (no OID)
  - Section 1274 does not apply to obligation assumptions
  - Does §483 apply?
- Addition to asset basis is delayed to when obligation becomes fixed (accrual and economic performance)
- But, if Buyer sells asset subject to the same contingent obligation before the obligation is added to asset basis, assumption of the obligation from Buyer is excluded from Buyer's amount realized on this sale (Reg. §1.1001-2(a)(3))

**Assumption of Contingent Obligations  
in Taxable Asset Acquisitions  
Consequences  
Fee Treatment**

- In *James M. Pierce Corp. v. Commissioner*, 326 F.2d 67 (1964), Seller owned a newspaper and received prepaid subscription fees
  - Seller initially set up a reserve and deferred the income under §455
  - Court held that when Seller sold the business, it had to accelerate the reserve into income
  - But the court also gave Seller a deduction
    - Buyer paid cash for reserve
    - Seller is deemed to turn around and pay Buyer a fee for assuming obligation to fill newspaper subscriptions
    - Thus Seller's income from the reserve was offset with a deduction for the "fee"
  - Deemed receipt of fee would be currently taxable to Buyer
  - Deemed reduction in purchase price for assumption of obligation is added back to Buyer's basis in purchased assets at closing
  - Payment of obligation should be currently deductible
  - *See also* Rev. Rul. 71-450

**Assumption of Contingent Obligations  
in Taxable Asset Acquisitions  
Consequences  
Fee Treatment  
Other Authorities**

- *TFH Publications v. Commissioner*, 72 T.C. 623 (1979): Acquisition of publishing company assets with agreement to provide future advertising services at a discount
- TAM 9823992: Prepaid subscription income treated as obligation assumed
- Fee approach has not received much support outside publication industry
- But preamble to a consolidated return regulation (T.D. 9376 (Jan. 16, 2008)) implies that fee theory applies in §332 liquidation if shareholder assumes obligation to provide future services (but supporting example involves prepaid subscription income)
- Different approach is implied in *In re Steen v. United States*, 509 F.2d 1398 (9<sup>th</sup> Cir. 1975) (buyer of uranium mine paid seller additional purchase price due to favorable state tax decision; *held*, open transaction; fee income to buyer not asserted)

**Assumption of Contingent Obligations  
in Taxable Asset Acquisitions  
Factors in Determining Treatment**

- Does the obligation result from Seller's or Buyer's activities
- Does the obligation arise out of pre-acquisition or post-acquisition events
- Did legal obligation arise before or after closing?
- Is there is express assumption by Buyer of the obligation and reflection in price?
- Was Buyer aware of obligation (balance sheet reserve) at closing?

## **Assumption of Contingent Obligations in Taxable Asset Acquisitions Factors**

### **First Factor: Results from Seller or Buyer Operations—*Holdcroft***

- Whether the obligation arises from—
  - Seller's or Buyer's operation of the business
  - Activities performed by Seller or Buyer
  - Events under Seller's or Buyer's control
  - Seller's or Buyer's decisions
- *Holdcroft Transportation Co. v. Commissioner*, 153 F.2d 323 (8<sup>th</sup> Cir. 1946):
  - Buyer buys assets for stock and assumption of obligations—including tort claims
  - Buyer pays claims and deducts payments
    - Buyer argues that it steps into Seller's shoes and may deduct payments
    - Buyer also argues it may deduct payments because claims were contingent
  - Court holds:
    - Claims arose out of Seller's business
    - Buyer may not deduct costs relating to Seller
    - Fact that obligation was contingent does not matter
    - Buyer assumed obligations part of costs of assets

## **Assumption of Contingent Obligations in Taxable Asset Acquisitions Factors**

### **First Factor: Results from Seller or Buyer Operations—Other Authorities**

- *Albany Car Wheel v. Commissioner*, 333 F.2d 653 (2<sup>nd</sup> Cir. 1964) – obligation arose after acquisition due to Buyer’s decision to close plant
- Rev. Rul. 76-520 – Buyer acquired newspaper business
  - Costs of filling prepaid subscriptions was assumed obligation because it relates to Seller operations
  - Costs of selling newspapers at newsstands deductible because they related to Buyer operations
- TAM 9721002 – acquisition and severance pay
  - “[A]lthough severance payments here were coincidental with Buyer's acquisition of Target, the severance payments had their origin in Buyer's termination of Target employees. While the acquisition may have been the catalyst for the employees' receipt of the severance payments, the acquisition was not itself the basis for the payments. Accordingly, the severance payments need not be capitalized and added to the basis of the stock purchased.”
- *Illinois Tool Works v. Commissioner*, 355 F.3d 997 (7<sup>th</sup> Cir. 2004)
  - Because the taxpayer knew of the pending patent infringement lawsuit, and agreed to pay that contingent obligation in exchange for purchasing the company, the taxpayer was not entitled to currently deduct the judgment as a business expense



## **Assumption of Contingent Obligations in Taxable Asset Acquisitions Factors**

### **Second Factor: Arises Out of Pre-Acquisition or Post-Acquisition Events**

- A factor closely related to the first factor is whether the obligation arises out of pre- or post-acquisition events
- For example, employee benefit cases:
  - Where there is a contract in place at time of acquisition to pay death benefits to employees
  - If employee dies after closing, obligation should be a Buyer obligation
  - If employee has died and Seller is obligated to pay, Buyer assumes obligation—no deduction to Buyer
- *M. Buten & Sons, Inc. v. Commissioner*, T.C. Memo 1972-44
  - Corporation agreed to assume liabilities of partnership in §351 transaction, including death benefits to surviving widows
  - No deduction for payments to widow of employee who died before the acquisition
  - Payments were deductible if employee died after the acquisition
- *David R. Webb Co., Inc. v. Commissioner*, 708 F.2d 1254 (7<sup>th</sup> Cir. 1983)
  - Buyer assumed Sellers obligation to make pension payments to wife of previously deceased employee
  - No deduction to Buyer

## **Assumption of Contingent Obligations in Taxable Asset Acquisitions Factors**

### **Third Factor: When did Legal Obligation Arise?**

- Courts have held that legal obligation for a tort arises when the tort occurs
  - *Holdcroft* and *Pacific Transport* support the idea that contingent nature of tort is not relevant
- Compare cases where obligation represents contractual claim, not tort (*Albany Car Wheel*)
  - Collective bargaining agreement required severance payments to employees upon plant shutdown
  - Purchase agreement called for express assumption of the severance obligation
  - After assets were transferred, plant was shut down, and Buyer made severance payments
  - Court held that obligation did not arise until after closing when plant shut down, and obligation arose on Buyer's side

## **Assumption of Contingent Obligations in Taxable Asset Acquisitions Factors**

### **Fourth Factor: Was Buyer Aware of Obligation?**

- *Pacific Transport v. Commissioner*, 483 F.2d 209 (9<sup>th</sup> Cir. 1973)
  - Parent corporation liquidated subsidiary (§334(b)(2)) and took assets and assumed liabilities, including a lawsuit
  - Parent believed its risk on the claim was remote.
  - Parent's risk assessment was wrong, and it ultimately paid claim.
  - Tax Court held that deduction was allowed, because claim was speculative and remote
  - Appeals court reversed and held that contingency was irrelevant
    - Because Buyer was aware of obligation, payment of claim was a cost of acquiring assets
    - No exception to capitalization for bad bargains
- Reserve for liability on Seller's balance sheet would make Buyer aware of obligation
- *But see Holdcroft Transportation Co. v. Commissioner*, 153 F.2d 323 (8<sup>th</sup> Cir. 1946)

## **Assumption of Contingent Obligations in Taxable Asset Acquisitions Factors**

### **Fifth Factor: Obligation Expressly Assumed by Buyer and Reflected in Price**

- Was purchase price reduced on account of the contingent obligation? If so, the obligation looks like an assumed liability
- This factor comes up often where:
  - Purchase price based on balance sheet
  - Reserve on balance sheet
- Allows IRS to argue that the liability was reflected in the price
- If Buyer expressly assumes a liability of Seller, courts generally conclude that Buyer assumes the liability
- This factor alone should not be dispositive (*Albany Car Wheel*)

## **Assumption of Contingent Obligations in Taxable Asset Acquisitions Contracts Transferred to Buyer**

- Acquired business may have favorable or unfavorable contracts, or both
- Favorability of a contract may be measured by reference to expected profit or loss on compliance or, even if profit is expected, based on baseline margin
- Under GAAP purchase accounting (PACO), Buyer must reserve for estimated costs of compliance with unfavorable contracts as additions to purchase price (FASB Statement No. 38)
- Consequently, if Buyer deducts these costs for tax purposes, Schedule M adjustments result
- Unfavorable contracts could be viewed as reduced-value assets instead of contingent liabilities under §1060, resulting in costs deductible to Buyer
- If net costs of compliance with unfavorable contracts were treated as contingent liabilities, should net income from favorable contracts be excluded from Buyer's income and treated as reduction in purchase price?
- PLR 200730014 (July 27, 2007)
  - Purchaser of gas marketing business paid customers to terminate pre-existing contracts to supply gas at fixed price and substitute contracts at fluctuating prices
  - Payments deductible to Buyer, not capitalized as adjustments to purchase price, because—
    - Obligations contingent on customers' gas purchases and market price
    - Contracts not taken into account in determining purchase price
- *Albany Car Wheel*
  - No step-up in cost basis of business assets for Buyer's payment of severance pay
  - Buyer negotiated new collective bargaining agreement providing for severance pay
- *See also* §1274(c)(4) (in asset purchase, interest not imputed to account for favorable or unfavorable financing)

# Assumption of Contingent Obligations in Taxable Asset Acquisitions — Discussion Problem Nuclear Power Plant Decommissioning

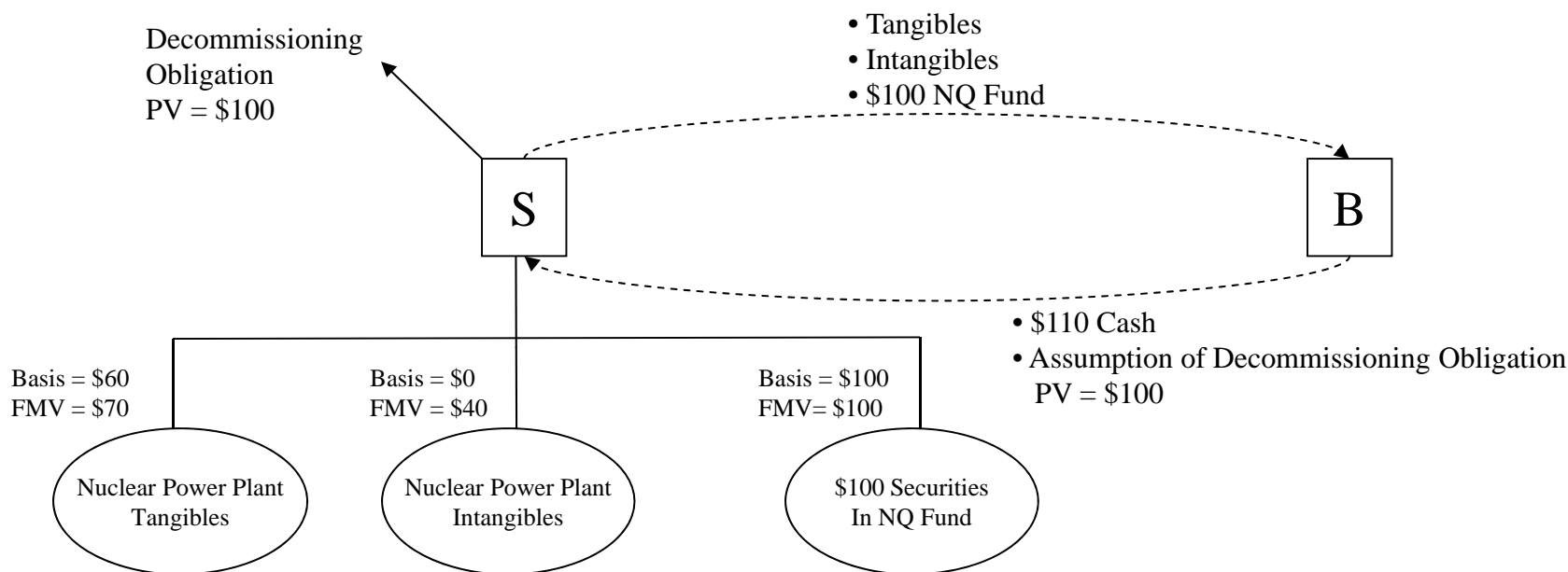

- S owns a nuclear power plant
  - S's basis in tangibles is \$60, and their FMV is \$70
  - S's basis in intangibles is \$0, and their FMV is \$40
  - The plant is expected to be decommissioned in 2051 at \$500 cost (present value \$100)
  - S has set aside securities (\$100 basis and FMV) in a "nonqualified fund" to fund this cost
- S sells the plant to B in 2011
  - S transfers the tangibles, intangibles and nonqualified fund to B
  - B pays S \$110 cash and assumes the decommissioning cost obligation
- Between the sale and 2051, the securities in the nonqualified fund increase in FMV to \$500
- In 2051, the plant is decommissioned at \$500 cost, paid out of the fund

PLR 200004040 (January 31, 2000) and other PLRs

Reg. §1.338-6(c)(5)

Contingent Obligations in  
Taxable Stock Acquisitions

**Contingent Obligations in  
Taxable Stock Acquisitions  
Non-Consolidated Return Situations**

- If Target stock is sold, and if contingent obligations remain with Target, the obligations should be reflected in purchase price
- Otherwise, there is no immediate tax effect to either Seller or Buyer
- Generally, there are no special consequences when the obligations become due and are paid
- Target deducts or capitalizes accrual and/or payment in accordance with usual tax accounting rules



# **Contingent Obligations in Taxable Stock Acquisitions Consolidated Return Regulations Transition Issues**

- If Seller sells Target stock during a consolidated return year, planning is needed:
  - If the contingent obligation generates a deduction on the day of sale, either the Seller's group or the Buyer's group may be claim the deduction, if the parties are consistent (Reg. §1.1502-76(b))
  - If the obligation is for deferred compensation under §404(a)(5), the deduction may have to belong to the Buyer's group
- If Seller's group claims the deduction—
  - Seller's basis in the Target stock is reduced (Reg. §1.1502-32), and its gain on the stock sale is increased (or its loss is decreased) by the same amount
  - If Target has a separate company loss for the year, this loss would seem to shelter gain on a sale of Target stock, but it would also reduce Seller's basis in the Target stock and so increase that gain. Thus, \$1 gain on the Target stock could use, or "churn and burn" all of Target's loss. The "anti-churn-and-burn" rule (Reg. §1.1502-11(b)) prevents this result by prohibiting Target's loss from offsetting gain on a sale of Target stock
- If Buyer's group is entitled to the deduction, a loss limitation under §382(h) or a separate return limitation rule (SRLY) limitation may result

**Contingent Obligations in  
Taxable Stock Acquisitions  
Consolidated Return Regulations  
Loss Disallowance or Attribute Reduction**

- If stock of consolidated Target is sold at a loss, the loss may be disallowed (Reg. §§1.1502-36(a)-(c))
- If the loss on the stock sale is allowed, Target's tax attributes (*e.g.*, loss carryovers or asset basis in excess of FMV) may be reduced after the sale to prevent double deduction (Reg. §1.1502-36(d))
  - If Target's "attribution reduction amount" (lesser of loss on stock sale or net inside loss) is greater than the amount of Target's attributes available for reduction, and if Target has contingent obligations, the excess attribute reduction amount is suspended and applied to prevent Target from deducting or capitalizing a later accrual and/or payment of the contingent obligations (Reg. §1.1502-36(d)(4)(ii)(C))
  - This rule would apply if, *e.g.*, Target has a contingent obligation and holds cash to pay the obligation
    - The basis of the cash cannot be reduced
    - The loss otherwise could be duplicated when Target accrues and/or pays the contingent obligation and deducts payment or increases cost basis in an asset
  - Seller can prevent this rule from applying to Buyer by electing to reduce its stock basis, to reattribute Target's loss carryovers or deferred deductions, or both

## Indemnities of Contingent Obligations

# Indemnities of Contingent Obligations

## Asset Sale or §338(h)(10) Stock Sale

### Discussion Problem—Facts

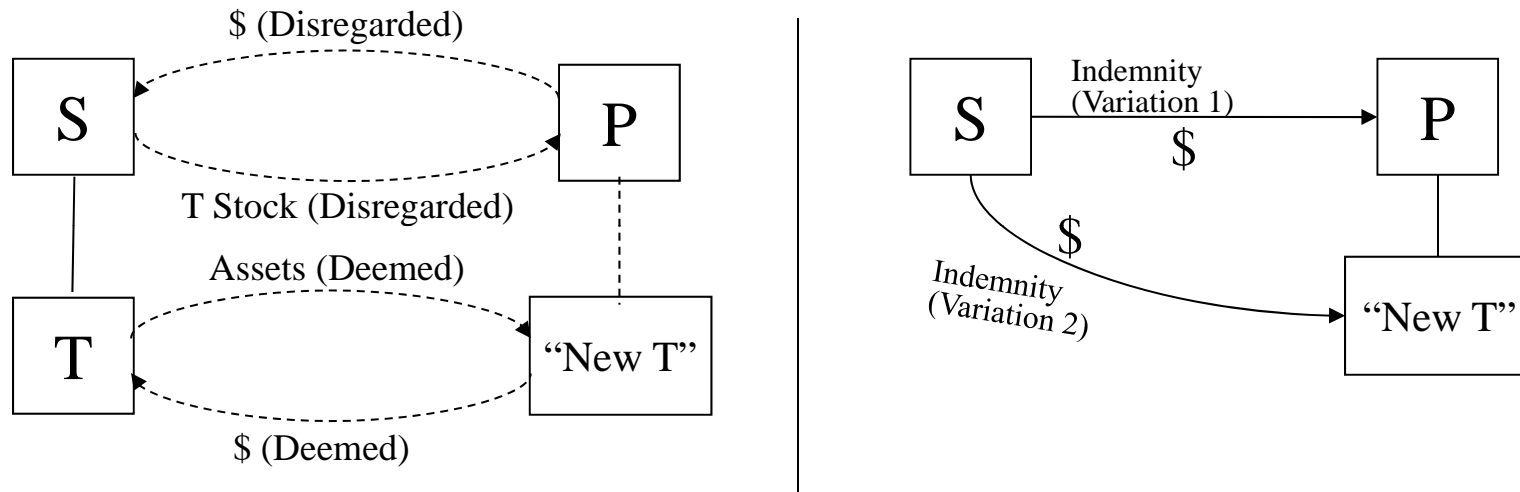

- S owns all the stock of T, which owns a manufacturing business
- S sells T stock to P for cash with §338(h)(10) election
  - At time of sale, T is defendant in patent infringement lawsuit
  - S agrees to indemnify P (Variation 1) or T (Variation 2) against an adverse judgment
  - Five years after closing, judgment is entered against T for damages plus interest back to three years before closing
  - S pays judgment

**Indemnities of Contingent Obligations**  
**Asset Sale or §338(h)(10) Stock Sale**  
**Discussion Problem—Analysis**

- If Seller indemnifies Buyer for a contingent obligation in an asset sale or a §338(h)(10) stock sale, no assumption of the obligation is considered to occur
- If accrual or payment of obligation is otherwise deductible, Seller is entitled to deduction when all-events and economic performance tests are met, as though no acquisition had occurred
- Buyer has no taxable income and no net effect basis of purchased assets (basis increase for payment of obligation and offsetting reduction for indemnity payment)

*Flood v. United States*, 133 F.2d 173 (1<sup>st</sup> Cir. 1943)

*Shannonhouse Estate v. Commissioner*, 21 T.C. 422 (1953)

Rev. Rul. 75-154, 1975-1 C.B. 186

# Indemnities of Contingent Obligations

## Stock Sale Without §338(h)(10)

### Discussion Problem—Facts

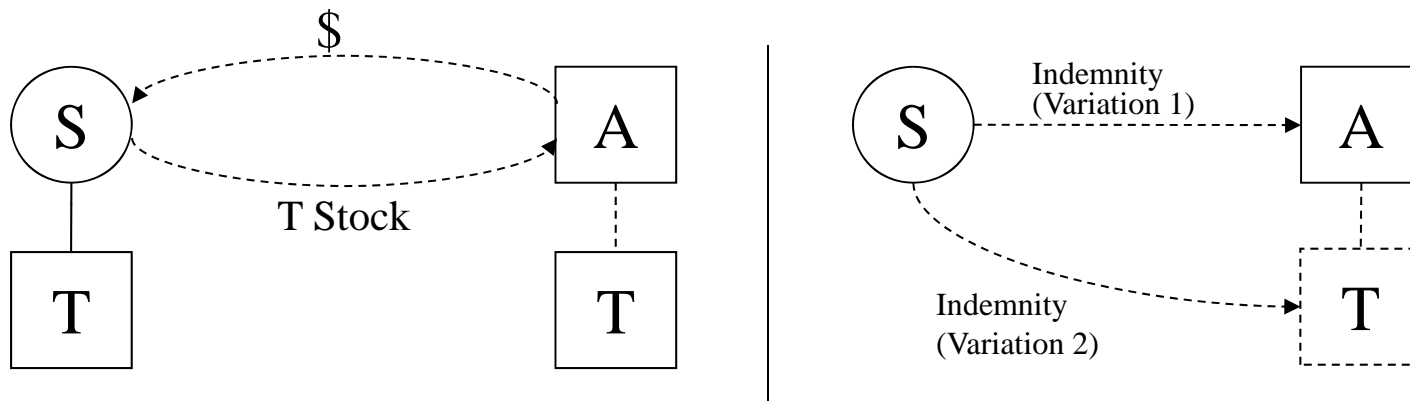

- S owns all the stock of T, which owns a manufacturing business
- T is defendant in a patent infringement lawsuit
- S sells the T stock to A for cash with no §338(h)(10) election
  - S agrees to indemnify A (Variation 1) or T (Variation 2) against an adverse judgment
  - Five years after closing, judgment is entered against T for damages
  - S pays the judgment

**Indemnities of Contingent Obligations**  
**Stock Sale Without §338(h)(10)**  
**Discussion Problem—Analysis**

- If Seller indemnifies Buyer for Target's contingent obligation in a stock sale, Seller is deemed to contribute indemnity payment to Target's capital, relating back to immediately before sale
  - Result is retroactive increase in S's stock basis
  - Seller is entitled to capital loss when its indemnity obligation accrues, and there is economic performance
  - Target has no taxable income or gain
  - Target deducts or capitalizes (in accordance with tax accounting rules) Seller's payment, deemed paid by Target
  - No effect on Buyer's basis in Target stock
- Same analysis in tax-free reorganization

*Estate of McGlothlin v. Commissioner*, 370 F.2d 729 (5th Cir. 1967)

*VCA Corporation v. United States*, 566 F.2d 1192 (Ct. Cl. 1977)

Rev. Rul. 58-374, 1958-2 C.B. 396

Rev. Rul. 83-73, 1983-1 C.B. 84

GCM 38977 (April 8, 1982)

## **Indemnities of Contingent Obligations**

### **Stock Sale with §338(h)(10)**

### **Insolvent Target**

- Indemnity of contingent obligation by shareholder could make the difference between Target being solvent or insolvent
- If Target was insolvent before indemnity, and Seller and Buyer elect §338(h)(10), contribution (indemnity payment) and deemed liquidation are stepped together
  - Section 338(h)(10) election still applies
  - Buyer gets cost basis in assets deemed purchased
  - Deemed distribution does not qualify under §332
  - Taxable distribution of any unwanted Target assets
  - Target's loss carryovers and other tax attributes are eliminated
  - Worthless stock deduction for Seller (could be ordinary deduction if §165(g)(3) is satisfied)

Rev. Rul. 68-602, 1968-2 C.B. 135 (contribution of intercompany debt disqualifies pre-planned actual liquidation from §332)

CCA 200818005 (January 29, 2008) (contribution of intercompany debt in connection with stock sale disqualifies deemed liquidation under §338(h)(10) from §332)



# Rescission

## Rescission – Issuance of PLRs

- In Rev. Proc. 2012-3, 2012-1 I.R.B. 113, the IRS added “[w]hether a completed transaction can be rescinded for Federal income tax purposes” as an area under study in which rulings will not be issued until the IRS resolves the issue through publication of a revenue ruling, a revenue procedure, regulations or otherwise.

# PLR 201016048

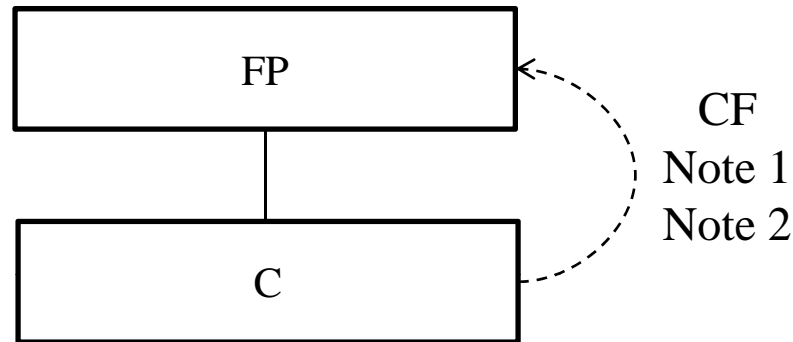

- Foreign parent FP owns all the stock of domestic corporation C
- C has debt to FP through a credit facility (CF), Note 1 and Note 2
- FP cancels Note 1 and CF in exchange for shares of C stock (section 108(e)(8))
- FP and C rescind the transaction in same tax year.
- Following the rescission, FP will cancel a portion of Note 1 and/or Note 2 as a capital contribution to C (section 108(e)(6))
- Taxpayer represented:
  - Neither [C] nor [FP] is or will be bound by any legal obligation regarding the Subsequent Debt Cancellation at or before the Effective Time of the Rescission
- Would the result be the same if, after rescission, Note 1 and CF are cancelled? See PLR 201008033

# PLR 200915031

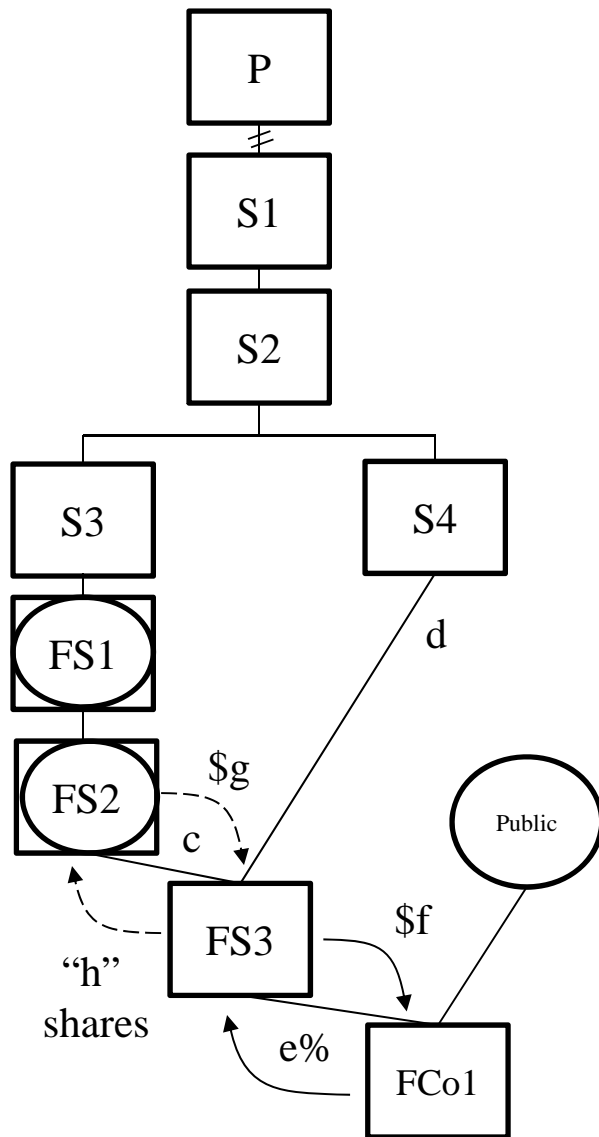

## Facts

- FS2 and S4 own c and d shares, respectively, in FS3.
- FS2 contributed \$g to FS3 in exchange for “h” FS3 shares.
- Based on the value of FS3 at the time of the \$g contribution, FS2 should have received “i” FS3 shares instead of “h” FS3 shares (“h” less “i” equals the “Excess Shares”).
- The number of shares issued were based on certain legal requirements under local country law, foreign regulatory and stamp considerations.

## Rescission

- FS3 will redeem the Excess Shares held by FS2 for no consideration (within the group’s taxable year).

## Ruling

- FS3 will be treated as not having issued the Excess Shares.

# PLR 200923010

## Original Structure

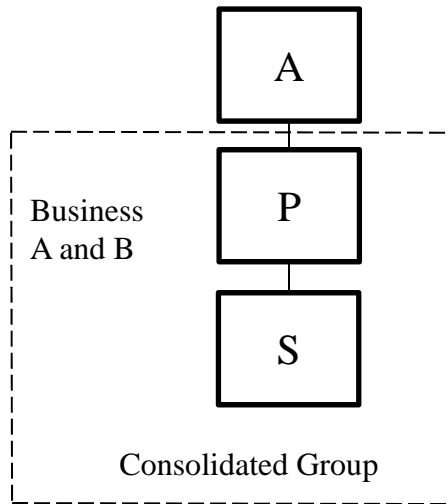

## Post split-off

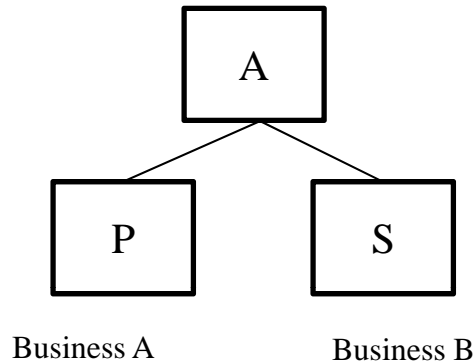

## Post Rescission

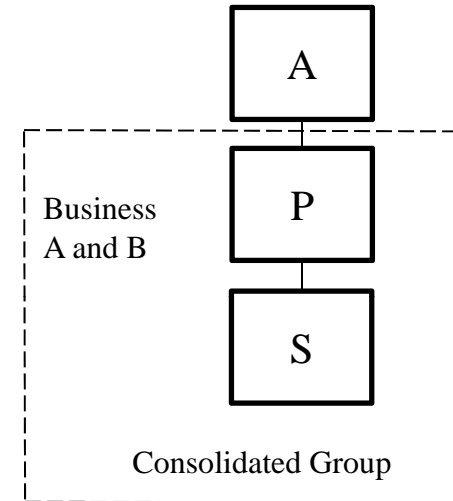

### Facts

- Taxpayer (P) is the parent of a consolidated group which initially includes S. As part of a section 355 splitoff, P transfers assets to S and subsequently distributes S to its sole shareholder, A, in redemption of y of the x shares of P stock held by A.
- The 355 split-off was initially undertaken to improve the “fit and focus” of business A and business B.
- Subsequent to the split-off, new management determined that the changed business environment reduced the benefits and increased the costs of separating the two businesses.

### Ruling

- The distribution and redemption are disregarded.
- The shares of S held by P and the shares of P held by A at the effective time of distribution and redemption will be treated as continuing to be outstanding.
- S will be treated as having remained a wholly-owned subsidiary of P and a member of the consolidated group at all times during the taxable year.

# PLR 200911004

## Beginning Structure

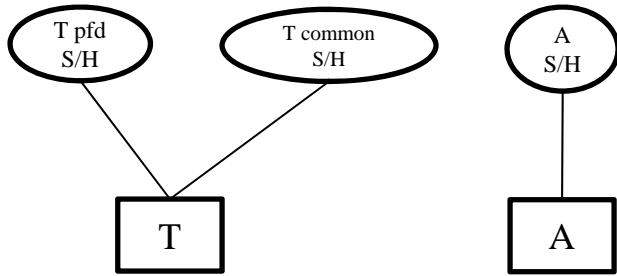

## Pfd Stock Purchase

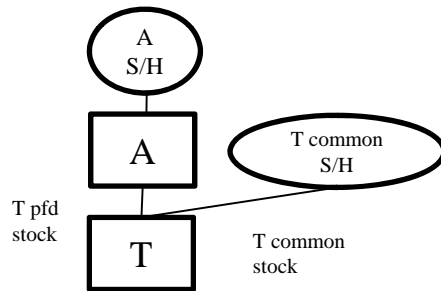

## Merger

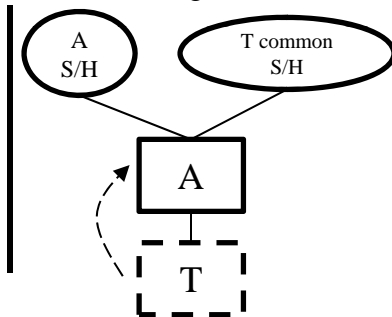

## Common Stock Purchase After Rescission of Merger

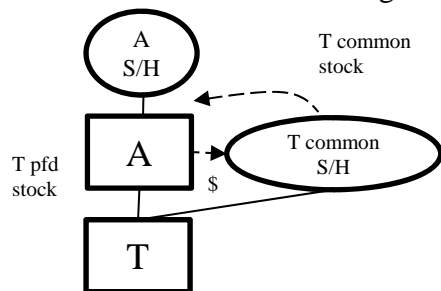

## Final Structure

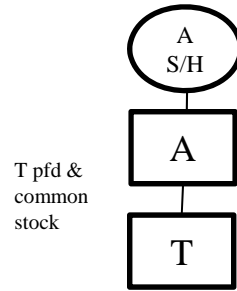

## Facts

- A purchases T convertible preferred stock, then T merges into A.
- Pursuant to the merger agreement, T's preferred stock held by A was cancelled.
- A realized that the merger may create tax consequences that could jeopardize its ability to continue as an ongoing entity.
- A, T, and certain T shareholders filed a petition in court to rescind the merger and to reinstate T as a corporation.
- In conjunction with the rescission of the merger and the Court's holding (described below), A purchased T's common stock.

## Court Holding

- T remained in existence.
- T common stockholders prior to the merger remained as the common stockholders after the rescission.
- A remained owner of the convertible preferred stock during the tax year.

## Ruling

- T will be treated as not merging into A.
- T and A will be treated as two separate corporations at all times during the tax year.
- A will be treated as acquiring all of the T common stock.

# PLR 200908016

## Beginning Structure

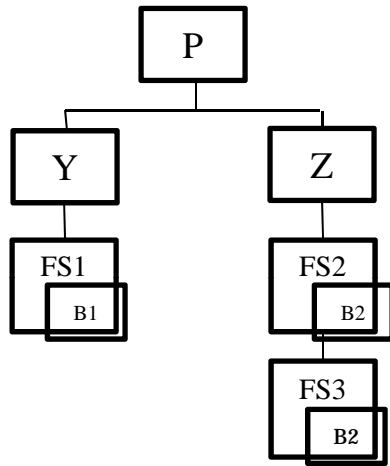

## Amalgamation

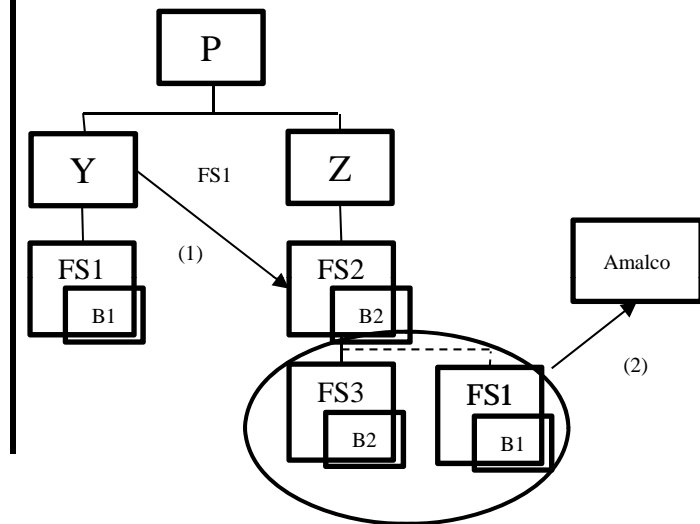

## Final Structure

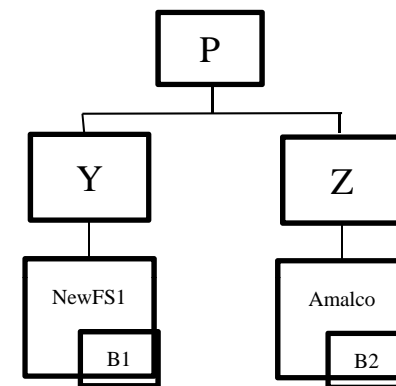

### Facts

- FS1 was engaged in Business 1 and FS2 and FS3 were engaged in Business 2.
- To combine Business 1 and Business 2, Y contributed all of its stock in FS1 to FS2 in exchange for FS2 stock.
- FS1, FS2, and FS3 were amalgamated into Amalco and FS1, FS2, and FS3 ceased to exist as entities separate from Amalco.
- Y rescinded its transfer and was treated as restored to its prior position (as the owner of New FS1, which contained all the assets and liabilities (other than assets disposed of by Amalco in the ordinary course of its business) formerly held by FS1).

### Ruling

- Y will be treated as owning all the stock of FS1 at all times from the effective date of the amalgamation through the effective date of the rescission transaction.
- FS1 and Amalco will be treated as two separate corporations at all times during the tax year.

Note: FS2 and FS3 remain in Amalco.